

# Serial Ethernet™

Manual

*All Mikroelektronika's development systems feature a large number of peripheral modules expanding microcontroller's range of application and making the process of program testing easier. In addition to these modules, it is also possible to use numerous additional modules linked to the development system through the I/O port connectors. Some of these additional modules can operate as stand-alone devices without being connected to the microcontroller.*

**Additional Board**

 **MikroElektronika**

SOFTWARE AND HARDWARE SOLUTIONS FOR EMBEDDED WORLD ...making it simple

## Serial Ethernet Additional Board

The *Serial Ethernet* additional board is used to connect a microcontroller to the Ethernet network. It features an on-board Ethernet controller ENC28J60 that exchanges data with microcontrollers via a standard Serial Peripheral Interface (SPI) at a data rate of up to 10 Mbit/s. It serves as an Ethernet interface for all microcontrollers supplied with SPI. There are three 10-pin IDC connectors marked SPI-dsPIC, SPI-AVR-8051 and SPI-PIC provided on the additional board. They enable the board to be connected to one of Mikroelektronika's development systems intended for work with dsPIC, PIC, AVR and 8051 microcontrollers. In addition to these connectors, the board also features a single-line 10-pin connector whose pins are connected to the ENC28J60's SPI communication lines. This connector enables the additional board to be connected to other microcontroller families.

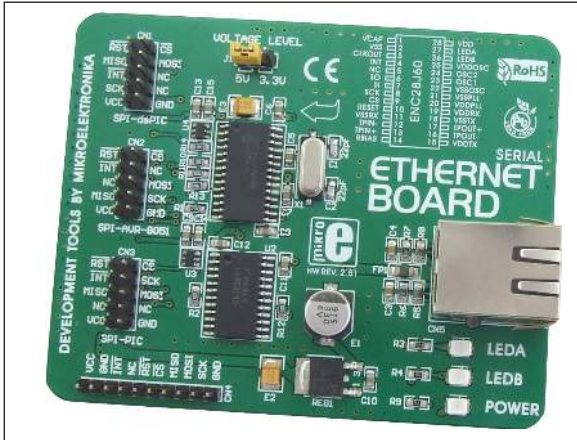

Figure 1: *Serial Ethernet* additional board

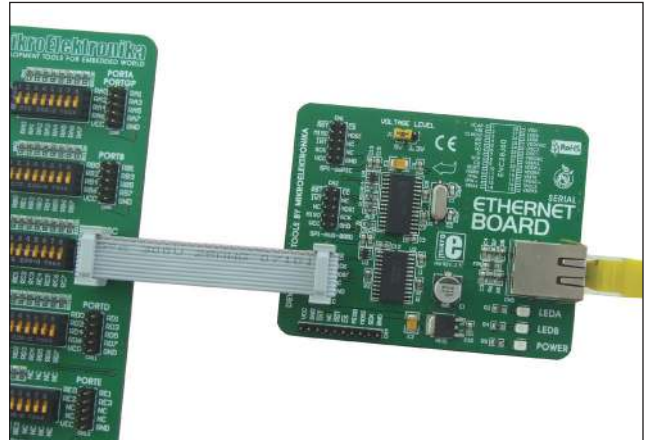

Figure 2: *Serial Ethernet* additional board connected to a development system

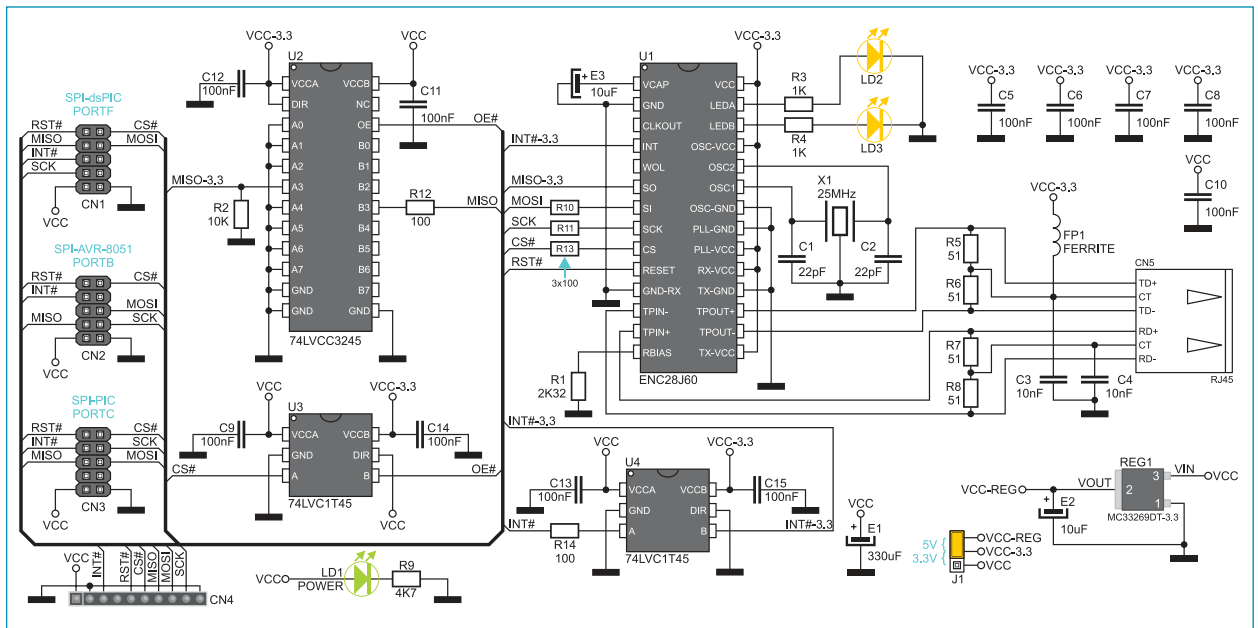

Figure 3: *Serial Ethernet* additional board connection schematic

# Serial Ethernet

The *Serial Ethernet* board features three LEDs:

POWER: indicates that the additional board is turned on;

LED A: indicates that the Ethernet cable is connected; and

LED B: indicates Ethernet network activity. It will be illuminated on every data package receive/transmitte.

The ENC28J60 requires the 3.3V power supply voltage, but it is designed to be easily used with 5V devices. Its input pins CS, SCK, SI and RESET are 5V tolerant, which means that it will be able to receive data from the microcontroller. However, if the microcontroller operates at 5V, it likely will not be able to receive data correctly from the Ethernet controller with 3.3V outputs. For this reason, voltage level translators, such as 74LVCC3245 and 74LVC1T45, that are used to adjust voltage levels are provided on the board.

The position of jumper J1 depends on the power supply voltage of the microcontroller connected to the *Serial Ethernet* additional board:

- If the power supply voltage is 5V, jumper J1 should be placed in the 5V position.
- If the power supply voltage is 3.3V, jumper J1 should be placed in the 3.3V position.

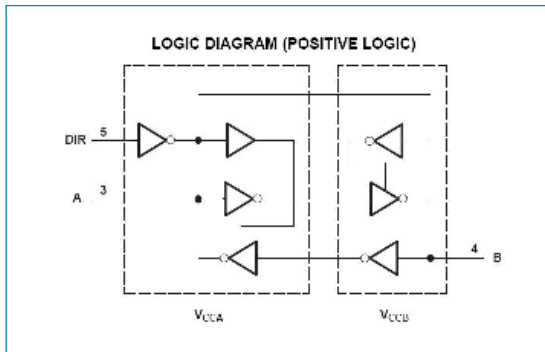

Figure 4: Block diagram of the 74LVC1T45 circuit

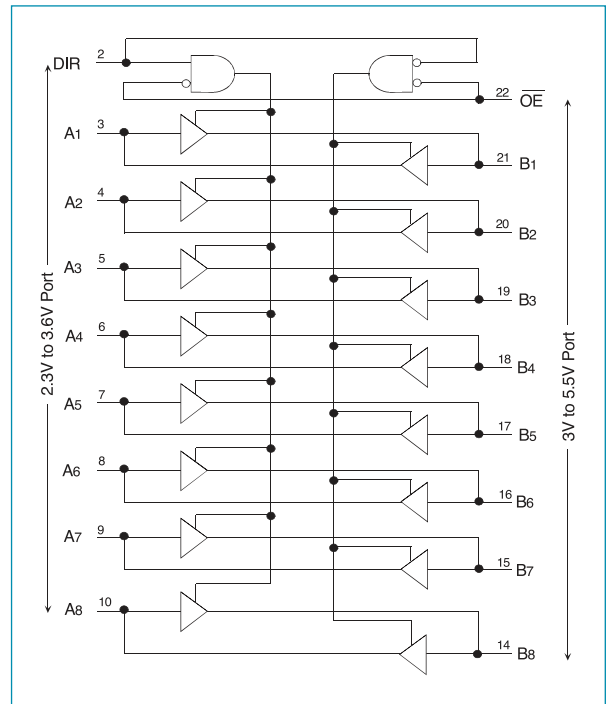

Figure 5: Block diagram of the 74LVCC3245 circuit



SOFTWARE AND HARDWARE SOLUTIONS FOR EMBEDDED WORLD

*...making it simple.*

If you want to learn more about our products, please visit our website at [www.mikroe.com](http://www.mikroe.com)

If you are experiencing some problems with any of our products or just need additional information, please place your ticket at [www.mikroe.com/en/support](http://www.mikroe.com/en/support)

If you have any questions, comments or business proposals, do not hesitate to contact us at [office@mikroe.com](mailto:office@mikroe.com)