



ON Semiconductor®

<http://onsemi.com>

# LC87F7J32A

CMOS IC

FROM 32K byte, RAM 1024 byte on-chip

## 8-bit 1-chip Microcontroller

### Overview

The LC87F7J32A is an 8-bit microcomputer that, centered around a CPU running at a minimum bus cycle time of 83.3ns, integrates on a single chip a number of hardware features such as 32K-byte flash ROM (onboard programmable), 1024-byte RAM, an on-chip debugger, a LCD controller/driver, sophisticated 16-bit timer/counter (may be divided into 8-bit timers), a 16-bit timer/counter (may be divided into 8-bit timers/counters or 8-bit PWMs), four 8-bit timers with a prescaler, a 16-bit timer with a prescaler (may be divided into 8-bit timers), a base timer serving as a time-of-day clock, a day and time counter, a synchronous SIO interface (with automatic block transmission/reception capabilities), an asynchronous/synchronous SIO interface, a UART interface (full duplex), two 12-bit PWM channels, a 12-bit/8-bit 10-channel AD converter, remote control receive function, a high-speed clock counter, a system clock frequency divider, an internal reset and a 25-source 10-vector interrupt feature.

### Features

#### ■Flash ROM

- Capable of on-board-programming with wide range, 3.0 to 5.5V, of voltage source
- Block-erasable in 128-byte units
- 32768 × 8 bits

#### ■RAM

- 1024 × 9 bits

#### ■Minimum Bus Cycle Time

- 83.3ns (12MHz)  $V_{DD}=3.0$  to 5.5V
- 125ns (8MHz)  $V_{DD}=2.5$  to 5.5V
- 250ns (4MHz)  $V_{DD}=2.2$  to 5.5V

Note: The bus cycle time here refers to the ROM read speed.

#### ■Minimum Instruction Cycle Time (tCYC)

- 250ns (12MHz)  $V_{DD}=3.0$  to 5.5V
- 375ns (8MHz)  $V_{DD}=2.5$  to 5.5V
- 750ns (4MHz)  $V_{DD}=2.2$  to 5.5V

\* This product is licensed from Silicon Storage Technology, Inc. (USA).

# LC87F7J32A

---

## ■ Ports

- Normal withstand voltage I/O ports
  - Ports whose I/O direction can be designated in 1 bit units 15 (P1n, P30 to P31, P70 to P73, XT2)
  - Ports whose I/O direction can be designated in 4 bit units 8 (P0n)  
(When N-channel open drain output is selected, data can be input in bit units.)
- Normal withstand voltage input port 1 (XT1)
- LCD ports
  - Segment output 24 (S00 to S23)
  - Common output 4 (COM0 to COM3)
  - Bias terminals for LCD driver 3 (V1 to V3)
- Other functions
  - Input/output ports 24 (PAn, PBn, PCn,)
  - Input ports 7 (PLn)
- Dedicated oscillator ports 2 (CF1, CF2)
- Reset pin 1 (RES)
- Power pins 6 (VSS1 to VSS3, VDD1 to VDD3)

## ■ LCD Controller

- 1) Seven display modes are available (static, 1/2, 1/3, 1/4 duty × 1/2, 1/3 bias)
- 2) Segment output and common output can be switched to general-purpose input/output ports

## ■ Timers

- Timer 0: 16-bit timer/counter with two capture registers.
  - Mode 0: 8-bit timer with an 8-bit programmable prescaler (with two 8-bit capture registers) × 2 channels
  - Mode 1: 8-bit timer with an 8-bit programmable prescaler (with two 8-bit capture registers)  
+ 8-bit counter (with two 8-bit capture registers)
  - Mode 2: 16-bit timer with an 8-bit programmable prescaler (with two 16-bit capture registers)
  - Mode 3: 16-bit counter (with two 16-bit capture registers)
- Timer 1: 16-bit timer that supports PWM/toggle outputs
  - Mode 0: 8-bit timer with an 8-bit prescaler (with toggle outputs)  
+ 8-bit timer/counter with an 8-bit prescaler (with toggle outputs)
  - Mode 1: 8-bit PWM with an 8-bit prescaler × 2 channels
  - Mode 2: 16-bit timer/counter with an 8-bit prescaler (with toggle outputs)  
(toggle outputs also possible from the lower-order 8 bits)
  - Mode 3: 16-bit timer with an 8-bit prescaler (with toggle outputs)  
(The lower-order 8 bits can be used as PWM.)
- Timer 4: 8-bit timer with a 6-bit prescaler
- Timer 5: 8-bit timer with a 6-bit prescaler
- Timer 6: 8-bit timer with a 6-bit prescaler (with toggle output)
- Timer 7: 8-bit timer with a 6-bit prescaler (with toggle output)
- Timer 8: 16-bit timer
  - Mode 0: 8-bit timer with an 8-bit prescaler × 2 channels (with toggle output)
  - Mode 1: 16-bit timer with an 8-bit prescaler (with toggle output)
- Base timer
  - 1) The clock is selectable from the subclock (32.768kHz crystal oscillation), system clock, and timer 0 prescaler output.
  - 2) Interrupts programmable in 5 different time schemes
- Day and time counter
  - 1) Using with a base timer, it can be used as 65000 day + minute + second counter.

## ■ High-speed Clock Counter

- 1) Can count clocks with a maximum clock rate of 20MHz (at a main clock of 10MHz).
- 2) Can generate output real-time.

## ■SIO

- SIO0: 8-bit synchronous serial interface
  - 1) LSB first/MSB first mode selectable
  - 2) Built-in 8-bit baudrate generator (maximum transfer clock cycle =  $4/3$  tCYC)
  - 3) Automatic continuous data transmission (1 to 256 bits specifiable in 1-bit units, suspension and resumption of data transmission possible in 1-byte units)
- SIO1: 8-bit asynchronous/synchronous serial interface
  - Mode 0: Synchronous 8-bit serial I/O (2- or 3-wire configuration, 2 to 512 tCYC transfer clocks)
  - Mode 1: Asynchronous serial I/O (half-duplex, 8-data bits, 1-stop bit, 8 to 2048 tCYC baudrates)
  - Mode 2: Bus mode 1 (start bit, 8-data bits, 2 to 512 tCYC transfer clocks)
  - Mode 3: Bus mode 2 (start detect, 8-data bits, stop detect)

## ■UART

- Full duplex
- 7/8/9 bit data bits selectable
- 1 stop bit (2-bit in continuous data transmission)
- Built-in baudrate generator

## ■AD Converter: 12-bits/8-bits × 12 channels

- 12 bits/8 bits AD converter resolution selectable

## ■PWM: Multi frequency 12-bit PWM × 2 channels

## ■Infrared Remote Control Receiver Circuit

- 1) Noise reduction function  
(noise filter time constant: Approx.  $120\mu\text{s}$ , when the 32.768kHz crystal oscillator is selected as the reference voltage source.)
- 2) Supports data encoding systems such as PPM (Pulse Position Modulation) and Manchester encoding
- 3) X'tal HOLD mode release function

## ■Watchdog Timer

- External RC watchdog timer
- Basetimer watchdog timer
- Interrupt and reset signals selectable

## ■Clock Output Function

- 1) Able to output selected oscillation clock  $1/1$ ,  $1/2$ ,  $1/4$ ,  $1/8$ ,  $1/16$ ,  $1/32$ ,  $1/64$  as system clock.
- 2) Able to output oscillation clock of sub clock.

# LC87F7J32A

## ■ Interrupts

- 25 sources, 10 vector addresses

- 1) Provides three levels (low (L), high (H), and highest (X)) of multiplex interrupt control. Any interrupt requests of the level equal to or lower than the current interrupt are not accepted.
- 2) When interrupt requests to two or more vector addresses occur at the same time, the interrupt of the highest level takes precedence over the other interrupts. For interrupts of the same level, the interrupt into the smallest vector address takes precedence.

No.	Vector Address	Level	Interrupt Source
1	00003H	X or L	INT0
2	0000BH	X or L	INT1
3	00013H	H or L	INT2/T0L/INT4/remote control receiver
4	0001BH	H or L	INT3/INT5/BT0/BT1
5	00023H	H or L	T0H
6	0002BH	H or L	T1L/T1H
7	00033H	H or L	SIO0/UART1 receive
8	0003BH	H or L	SIO1/UART1 transmit
9	00043H	H or L	ADC/T6/T7/PWM4/PWM5
10	0004BH	H or L	Port 0/T4/T5

- Priority levels  $X > H > L$
- Of interrupts of the same level, the one with the smallest vector address takes precedence.

- IFLG (List of interrupt source flag function)

- 1) Shows a list of interrupt source flags that caused a branching to a particular vector address (shown in the diagram above).

## ■ Subroutine Stack Levels: 512 levels (The stack is allocated in RAM.)

## ■ High-speed Multiplication/Division Instructions

- 16 bits  $\times$  8 bits (5 tCYC execution time)
- 24 bits  $\times$  16 bits (12 tCYC execution time)
- 16 bits  $\div$  8 bits (8 tCYC execution time)
- 24 bits  $\div$  16 bits (12 tCYC execution time)

## ■ Oscillation Circuits

- RC oscillation circuit (internal): For system clock
- CF oscillation circuit: For system clock, with internal Rf
- Crystal oscillation circuit: For low-speed system clock, with internal Rf
- Frequency variable RC oscillation circuit (internal): For system clock
  - 1) Adjustable in  $\pm 4\%$  (typ) step from a selected center frequency.
  - 2) Measures oscillation clock using a input signal from XT1 as a reference.

## ■ System Clock Divider Function

- Can run on low current.
- The minimum instruction cycle selectable from 300ns, 600ns, 1.2 $\mu$ s, 2.4 $\mu$ s, 4.8 $\mu$ s, 9.6 $\mu$ s, 19.2 $\mu$ s, 38.4 $\mu$ s, and 76.8 $\mu$ s (at a main clock rate of 10MHz).

## ■ Internal Reset Function

- Power-On-Reset (POR) function
  - 1) POR resets the system when the power supply voltage is applied.
  - 2) POR release level is selectable from 4 levels (2.07V, 2.37V, 2.87V, 4.35V) by option.
- Low Voltage Detection reset (LVD) function
  - 1) LVD used with POR resets the system when the supply voltage is applied and when it is lowered.
  - 2) LVD function is selectable from enable/disable and the reset level is selectable from 3 levels (2.31V, 2.81V, 4.28V) by option.

# LC87F7J32A

## ■ Standby Function

- HALT mode: Halts instruction execution while allowing the peripheral circuits to continue operation.  
(Some parts of the serial transfer function stops operation)
  - 1) Oscillation is not halted automatically.
  - 2) Canceled by a system reset or occurrence of an interrupt
- HOLD mode: Suspends instruction execution and the operation of the peripheral circuits.
  - 1) The CF, RC, X'tal, and frequency variable RC oscillators automatically stop operation.
  - 2) There are three ways of resetting the HOLD mode.
    - (1) Setting the reset pin to the low level
    - (2) Setting at least one of the INT0, INT1, INT2, INT4, and INT5, pins to the specified level
    - (3) Having an interrupt source established at port 0
- X'tal HOLD mode: Suspends instruction execution and the operation of the peripheral circuits except the base timer and the remote control circuit.
  - 1) The CF, RC, and frequency variable RC oscillators automatically stop operation
  - 2) The state of crystal oscillation established when the X'tal HOLD mode is entered is retained.
  - 3) There are five ways of resetting the X'tal HOLD mode.
    - (1) Setting the reset pin to the low level
    - (2) Setting at least one of the INT0, INT1, INT2, INT4, and INT5 pins to the specified level
    - (3) Having an interrupt source established at port 0
    - (4) Having an interrupt source established in the base timer circuit
    - (5) Having an interrupt source established in the infrared remote control receiver circuit

## ■ On-chip Debugger

- Supports software debugging with the IC mounted on the target board.

## ■ Package Form

- QIP64E(14×14): Lead-free type
- TQFP64J(10×10): Lead-free type

## ■ Development Tools

- On-chip debugger: TCB87-TypeB + LC87F7J32A

## ■ Flash ROM Programming Board

Package	Programming boards
QIP64E(14×14)	W87F50256Q
TQFP64J(10×10)	W87F57256SQ

## ■ Flash ROM Programmer

Maker	Model		Supported Version (Note)	Device
Flash Support Group, Inc. (Formerly Ando Electric Co., Ltd.)	Single	AF9708/AF9709/ AF9709B	After 0x.xx	
	Gang	AF9723 (Main body)	After 0x.xx	
		AF9833 (Unit)	After 0x.xx	
Our company	SKK (SANYO FWS)		After x.xxA	LC87F7J32A

Note: Please check the latest version.

## ■ Same Package and Pin Assignment as Mask ROM Version.

- 1) LC877J00 series options can be set by using flash ROM data. Thus the board used for mass production can be used for debugging and evaluation without modifications.
- 2) If the program for the mask ROM version is used, the usable ROM/RAM capacity is the same as the mask ROM version.

**Package Dimensions**

unit : mm (typ)

3159A

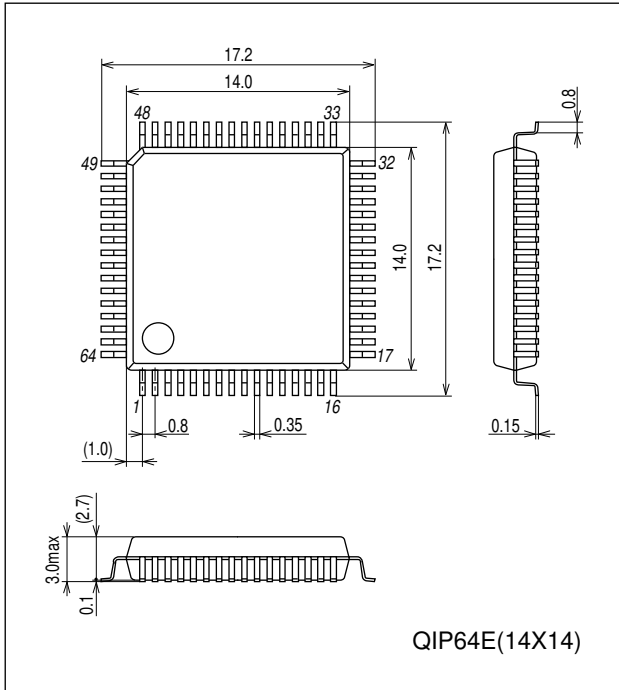

**Package Dimensions**

unit : mm (typ)

3310

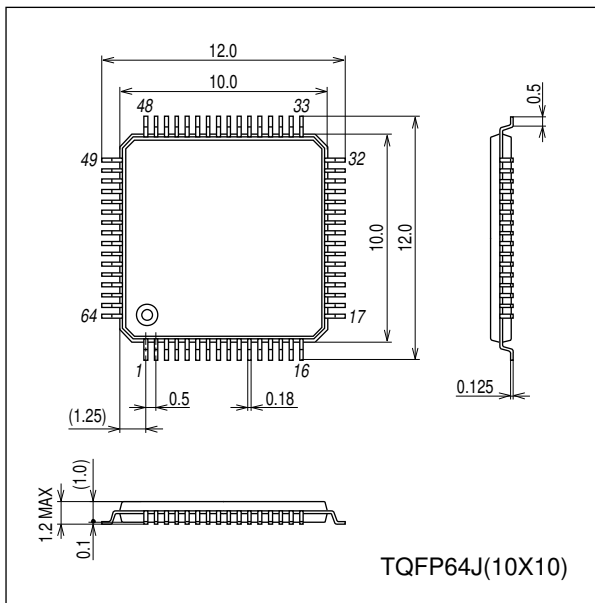

# LC87F7J32A

## Pin Assignment

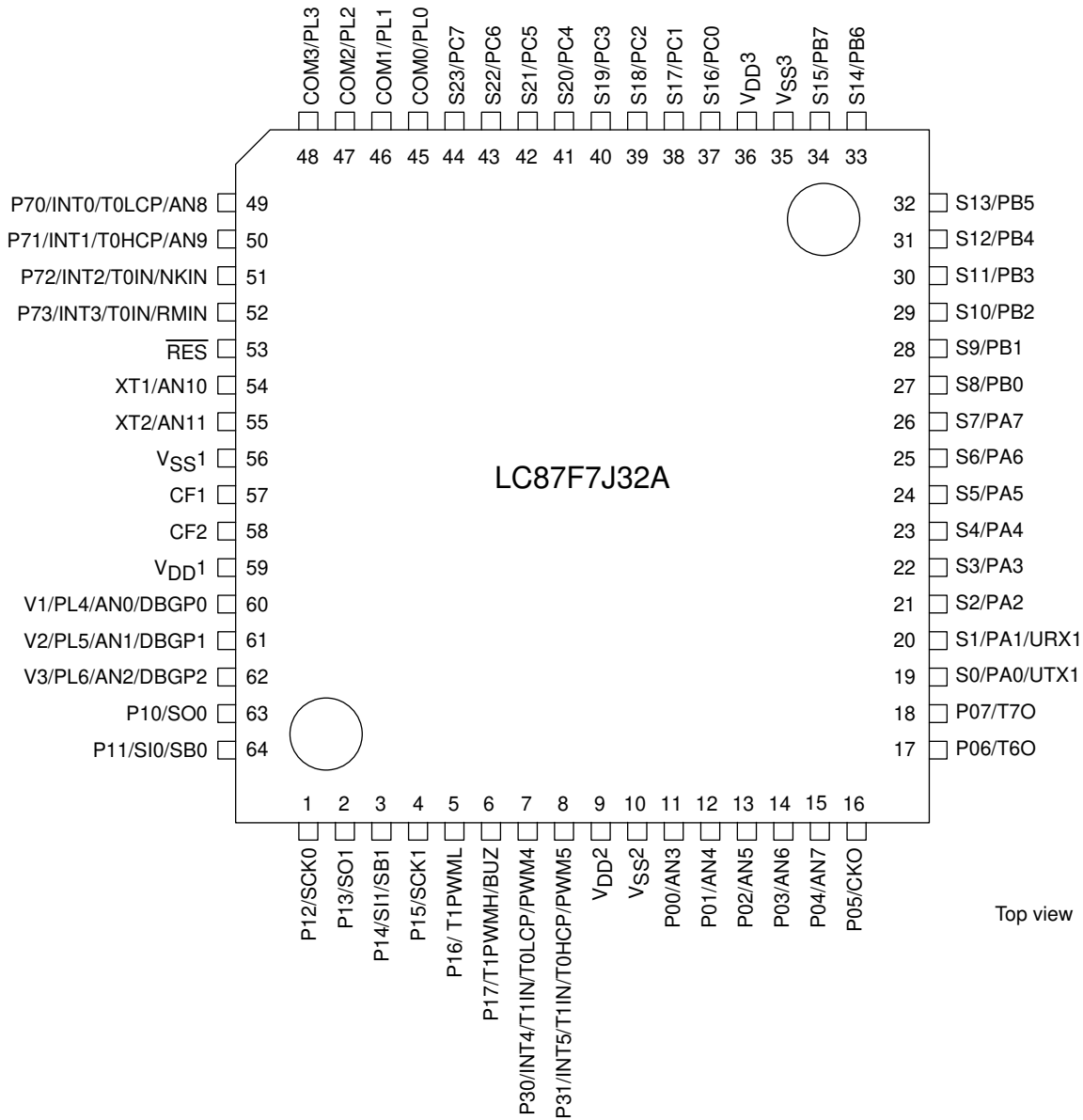

QIP64E(14×14) “Lead-free Type”

TQFP64J(10×14) “Lead-free Type”

# LC87F7J32A

PIN No.	NAME
1	P12/SCK0
2	P13/SO1
3	P14/SI1/SB1
4	P15/SCK1
5	P16/T1PWML
6	P17/T1PWMH/BUZ
7	P30/INT4/T1IN/TOLCP1/PWM4
8	P31/INT5/T1IN/T0HCP1/PWM5
9	V <sub>DD2</sub>
10	V <sub>SS2</sub>
11	P00/AN3
12	P01/AN4
13	P02/AN5
14	P03/AN6
15	P04/AN7
16	P05/CKO
17	P06/T6O
18	P07/T7O
19	S0/PA0/UTX1
20	S1/PA1/URX1
21	S2/PA2
22	S3/PA3
23	S4/PA4
24	S5/PA5
25	S6/PA6
26	S7/PA7
27	S8/PB0
28	S9/PB1
29	S10/PB2
30	S11/PB3
31	S12/PB4
32	S13/PB5

PIN No.	NAME
33	S14/PB6
34	S15/PB7
35	V <sub>SS3</sub>
36	V <sub>DD3</sub>
37	S16/PC0
38	S17/PC1
39	S18/PC2
40	S19/PC3
41	S20/PC4
42	S21/PC5
43	S22/PC6
44	S23/PC7
45	COM0/PL0
46	COM1/PL1
47	COM2/PL2
48	COM3/PL3
49	P70/INT0/T0LCP/AN8
50	P71/INT1/T0HCP/AN9
51	P72/INT2/T0IN
52	P73/INT3/T0IN
53	RES
54	XT1/AN10
55	XT2/AN11
56	V <sub>SS1</sub>
57	CF1
58	CF2
59	V <sub>DD1</sub>
60	V1/PL4/AN0/DBGP0
61	V2/PL5/AN1/DBGP1
62	V3/PL6/AN2/DBGP2
63	P10/SO0
64	P11/SI0/SB0



System Block Diagram

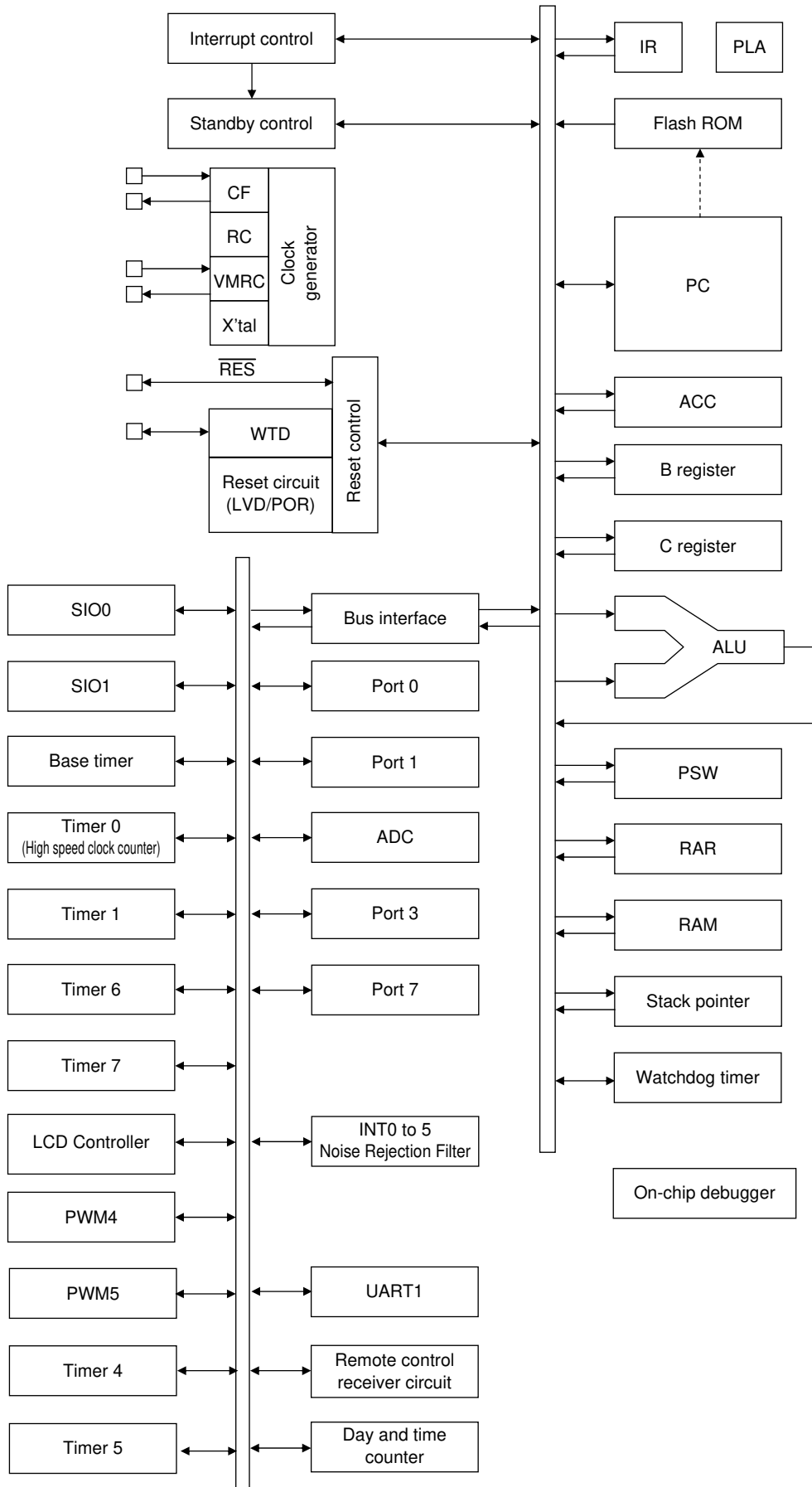

# LC87F7J32A

## Pin Description

Pin Name	I/O	Description	Option																														
V <sub>SS</sub> 1 V <sub>SS</sub> 2 V <sub>SS</sub> 3	-	- power supply pin	No																														
V <sub>DD</sub> 1 V <sub>DD</sub> 2 V <sub>DD</sub> 3	-	+ power supply pin	No																														
PORT0 P00 to P07	I/O	<ul style="list-style-type: none"> <li>8-bit I/O port</li> <li>I/O specifiable in 4-bit units</li> <li>Pull-up resistors can be turned on and off in 4-bit units.</li> <li>Input for HOLD release</li> <li>Input for port 0 interrupt</li> <li>Shared pins P00 to P04: AD converter input (AN3 to AN7) P05: Clock output (system clock/can selected from sub clock) P06: Timer 6 toggle output P07: Timer 7 toggle output</li> </ul>	Yes																														
PORT1 P10 to P17	I/O	<ul style="list-style-type: none"> <li>8-bit I/O port</li> <li>I/O specifiable in 1-bit units</li> <li>Pull-up resistors can be turned on and off in 1-bit units.</li> <li>Shared pins P10: SIO0 data output P11: SIO0 data input/bus I/O P12: SIO0 clock I/O P13: SIO1 data output P14: SIO1 data input/bus I/O P15: SIO1 clock I/O P16: Timer 1PWML output P17: Timer 1PWMLH output/beeper output</li> </ul>	Yes																														
PORT3 P30 to P31	I/O	<ul style="list-style-type: none"> <li>2-bit I/O port</li> <li>I/O specifiable in 1-bit units</li> <li>Pull-up resistors can be turned on and off in 1-bit units.</li> <li>Shared pins P30: INT4 input/HOLD release input/timer 1 event input/timer 0L capture input/PWM4 P31: INT5 input/HOLD release input/timer 1 event input/timer 0L capture input/PWM5</li> <li>Interrupt acknowledge type</li> </ul> <table border="1" style="width: 100%; text-align: center;"> <thead> <tr> <th></th> <th>Rising</th> <th>Falling</th> <th>Rising &amp; Falling</th> <th>H level</th> <th>L level</th> </tr> </thead> <tbody> <tr> <td>INT4</td> <td>enable</td> <td>enable</td> <td>enable</td> <td>disable</td> <td>disable</td> </tr> <tr> <td>INT5</td> <td>enable</td> <td>enable</td> <td>enable</td> <td>disable</td> <td>disable</td> </tr> </tbody> </table>		Rising	Falling	Rising & Falling	H level	L level	INT4	enable	enable	enable	disable	disable	INT5	enable	enable	enable	disable	disable	Yes												
	Rising	Falling	Rising & Falling	H level	L level																												
INT4	enable	enable	enable	disable	disable																												
INT5	enable	enable	enable	disable	disable																												
PORT7 P70 to P73	I/O	<ul style="list-style-type: none"> <li>4-bit I/O port</li> <li>I/O specifiable in 1-bit units</li> <li>Pull-up resistors can be turned on and off in 1-bit units.</li> <li>Shared pins P70: INT0 input/HOLD release input/timer 0L capture input/watchdog timer output P71: INT1 input/HOLD release input/timer 0H capture input P72: INT2 input/HOLD release input/timer 0 event input/timer 0L capture input/ high speed clock counter input P73: INT3 input (with noise filter)/timer 0 event input/timer 0H capture input/ remote control receiver input AD converter input ports: AN8 (P70), AN9 (P71)</li> <li>Interrupt acknowledge type</li> </ul> <table border="1" style="width: 100%; text-align: center;"> <thead> <tr> <th></th> <th>Rising</th> <th>Falling</th> <th>Rising &amp; Falling</th> <th>H level</th> <th>L level</th> </tr> </thead> <tbody> <tr> <td>INT0</td> <td>enable</td> <td>enable</td> <td>disable</td> <td>enable</td> <td>enable</td> </tr> <tr> <td>INT1</td> <td>enable</td> <td>enable</td> <td>disable</td> <td>enable</td> <td>enable</td> </tr> <tr> <td>INT2</td> <td>enable</td> <td>enable</td> <td>enable</td> <td>disable</td> <td>disable</td> </tr> <tr> <td>INT3</td> <td>enable</td> <td>enable</td> <td>enable</td> <td>disable</td> <td>disable</td> </tr> </tbody> </table>		Rising	Falling	Rising & Falling	H level	L level	INT0	enable	enable	disable	enable	enable	INT1	enable	enable	disable	enable	enable	INT2	enable	enable	enable	disable	disable	INT3	enable	enable	enable	disable	disable	No
	Rising	Falling	Rising & Falling	H level	L level																												
INT0	enable	enable	disable	enable	enable																												
INT1	enable	enable	disable	enable	enable																												
INT2	enable	enable	enable	disable	disable																												
INT3	enable	enable	enable	disable	disable																												

Continued on next page.

## LC87F7J32A

Continued from preceding page.

Pin Name	I/O	Description	Option
S0/PA0 to S7/PA7	I/O	<ul style="list-style-type: none"> <li>• Segment output for LCD</li> <li>• Can be used as general-purpose I/O port (PA)</li> </ul>	No
S8/PB0 to S15/PB7	I/O	<ul style="list-style-type: none"> <li>• Segment output for LCD</li> <li>• Can be used as general-purpose I/O port (PB)</li> </ul>	No
S16/PC0 to S23/PC7	I/O	<ul style="list-style-type: none"> <li>• Segment output for LCD</li> <li>• Can be used as general-purpose I/O port (PC)</li> </ul>	No
COM0/PL0 to COM3/PL3	I/O	<ul style="list-style-type: none"> <li>• Common output for LCD</li> <li>• Can be used as general-purpose input port (PL)</li> </ul>	No
V1/PL4 to V3/PL7	I/O	<ul style="list-style-type: none"> <li>• LCD output bias power supply</li> <li>• Can be used as general-purpose input port (PL)</li> <li>• Shared pins</li> <li>AD converter input ports: AN0 (V1) to AN2 (V3)</li> <li>On-chip debugger pins: DBGP0 (V1) to DBGP2 (V3)</li> </ul>	No
$\overline{\text{RES}}$	Input	Reset pin	No
XT1	Input	<ul style="list-style-type: none"> <li>• 32.768kHz crystal oscillator input pin</li> <li>• Shared pins</li> <li>General-purpose input port</li> <li>AD converter input port: AN10</li> <li>Must be connected to <math>V_{DD1}</math> if not to be used.</li> </ul>	No
XT2	I/O	<ul style="list-style-type: none"> <li>• 32.768kHz crystal oscillator output pin</li> <li>• Shared pins</li> <li>General-purpose I/O port</li> <li>AD converter input port: AN11</li> <li>Must be set for oscillation and kept open if not to be used.</li> </ul>	No
CF1	Input	Ceramic resonator input pin	No
CF2	Output	Ceramic resonator output pin	No

## Port Output Types

The table below lists the types of port outputs and the presence/absence of a pull-up resistor. Data can be read into any input port even if it is in the output mode.

Port Name	Option Selected in Units of	Option Type	Output Type	Pull-up Resistor
P00 to P07	1 bit	1	CMOS	Programmable (Note)
		2	N-channel open drain	No
P10 to P17	1 bit	1	CMOS	Programmable
		2	N-channel open drain	Programmable
P30 to P31	1 bit	1	CMOS	Programmable
		2	N-channel open drain	Programmable
P70	-	No	N-channel open drain	Programmable
P71 to P73	-	No	CMOS	Programmable
S0/PA0 to S23/PC7	-	No	CMOS	Programmable
COM0/PL0 to COM3/PL3	-	No	Input only	No
V1/PL4 to V3/PL6	-	No	Input only	No
XT1	-	No	Input for 32.768 kHz crystal oscillator (Input only)	No
XT2	-	No	Output for 32.768kHz crystal oscillator (Nch-open drain when in general-purpose output mode)	No

Note1: Programmable pull-up resistors for port 0 are controlled in 4 bit units (P00 to 03, P04 to 07).

- \*1 Connect the IC as shown below to minimize the noise input to the  $V_{DD1}$  pin.  
Be sure to electrically short the  $V_{SS1}$ ,  $V_{SS2}$ , and  $V_{SS3}$  pins.

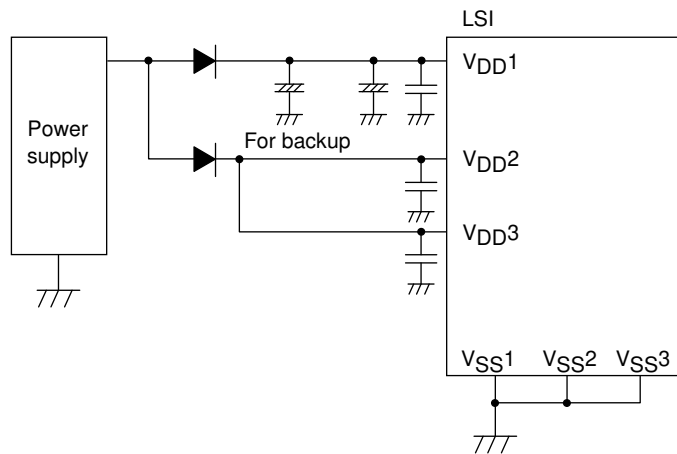

- \*2 The internal memory is sustained by  $V_{DD1}$ . If none of  $V_{DD2}$  and  $V_{DD3}$  are backed up, the high level output at the ports are unstable in the HOLD backup mode, allowing through current to flow into the input buffer and thus shortening the backup time.  
Make sure that the port outputs are held at the low level in the HOLD backup mode.

# LC87F7J32A

## Absolute Maximum Ratings at Ta = 25°C, VSS1 = VSS2 = VSS3 = 0V

Parameter	Symbol	Pin/Remarks	Conditions	Specification				unit
				VDD[V]	min	typ	max	
Maximum supply voltage	VDD max	VDD1, VDD2, VDD3	VDD1=VDD2=VDD3		-0.3		+6.5	V
supply voltage for LCD	VLCD	V1/PL4, V2/PL5, V3/PL6	VDD1=VDD2=VDD3		-0.3		VDD	
Input voltage	VI(1)	Port L XT1, CF1, $\overline{\text{RES}}$			-0.3		VDD+0.3	
Input/output voltage	VI(1)	Port 0, 1, 3, 7 Port A, B, C XT2			-0.3		VDD+0.3	
High level output current	Peak output current	IOPH(1)	Ports 0, 1 Ports A, B, C	• CMOS output selected • Current at each pin		-10		mA
		IOPH(2)	Port 3	• CMOS output selected • Current at each pin		-20		
		IOPH(3)	Port 71 to 73	Current at each pin		-5		
	Mean output current (Note 1-1)	IOMH(1)	Ports 0, 1 Ports A, B, C	• CMOS output selected • Current at each pin		-7.5		
		IOMH(2)	Port 3	• CMOS output selected • Current at each pin		-15		
		IOMH(3)	Ports 71 to 73	Current at each pin		-3		
	Total output current	ΣIOAH(1)	Ports 71 to 73	Total of all pins		-5		
		ΣIOAH(2)	Port 1	Total of all pins		-20		
		ΣIOAH(3)	Ports 1, 71 to 73	Total of all pins		-20		
		ΣIOAH(4)	Port 3	Total of all pins		-25		
		ΣIOAH(5)	Port 0	Total of all pins		-20		
		ΣIOAH(6)	Ports 0, 3	Total of all pins		-40		
ΣIOAH(7)		Ports A, B	Total of all pins		-25			
ΣIOAH(8)		Port C	Total of all pins		-20			
ΣIOAH(9)		Ports A, B, C	Total of all pins		-10			
Low level output current	Peak output current	IOPL(1)	Ports 0, 1 Ports A, B, C	Current at each pin			20	
		IOPL(2)	Port 3	Current at each pin			30	
		IOPL(3)	Ports 7, XT2	Current at each pin			10	
	Mean output current (Note 1-1)	IOML(1)	Ports 0, 1 Ports A, B, C	Current at each pin			15	
		IOML(2)	Port 3	Current at each pin			20	
		IOML(3)	Ports 7, XT2	Current at each pin			7.5	
	Total output current	ΣIOAL(1)	Ports 7, XT2	Total of all pins			15	
		ΣIOAL(2)	Ports 1	Total of all pins			40	
		ΣIOAL(3)	Ports 1, 7, XT2	Total of all pins			50	
		ΣIOAL(4)	Port 3	Total of all pins			45	
		ΣIOAL(5)	Port 0	Total of all pins			40	
		ΣIOAL(6)	Ports 0, 3	Total of all pins			80	
ΣIOAL(7)		Ports A, B	Total of all pins			45		
ΣIOAL(8)		Port C	Total of all pins			40		
ΣIOAL(9)		Ports A, B, C	Total of all pins			80		
Power dissipation	Pd max	QIP64E(14×14)	Ta=-40 to +85°C				298	mW
		TQFP64J(10×10)	Ta=-40 to +85°C					
Operating ambient temperature	Topr				-40		+85	°C
Storage ambient temperature	Tstg				-55		+125	

Note 1-1: The mean output current is a mean value measured over 100ms.

Stresses exceeding Maximum Ratings may damage the device. Maximum Ratings are stress ratings only. Functional operation above the Recommended Operating Conditions is not implied. Extended exposure to stresses above the Recommended Operating Conditions may affect device reliability.

## LC87F7J32A

### Allowable Operating Conditions at Ta = -40°C to +85°C, VSS1 = VSS2 = VSS3 = 0V

Parameter	Symbol	Pin/Remarks	Conditions	Specification					
				VDD[V]	min	typ	max	unit	
Operating supply voltage (Note 2-1)	VDD(1)	VDD1=VDD2=VDD3	0-237μs≤tCYC≤200μs		3.0		5.5	V	
			0-356μs≤tCYC≤200μs		2.5		5.5		
			0-712μs≤tCYC≤200μs		2.2		5.5		
Memory sustaining supply voltage	VHD	VDD1=VDD2=VDD3	RAM and register contents sustained in HOLD mode		2.0		5.5		
High level input voltage	VIH(1)	• Ports 0, 3 • Ports A, B, C • Port L	Output disabled	2.2 to 5.5	0.3VDD +0.7		VDD	V	
			• Port 1 • Ports 71 to 73 • Port 70 port input/ interrupt side	• Output disabled • When INT1VTSL=0 (P71 only)	2.2 to 5.5	0.3VDD +0.7			VDD
				• Output disabled • When INT1VTSL=1	2.2 to 5.5	0.85VDD			VDD
				Output disabled	2.2 to 5.5	0.9VDD			VDD
				XT1, XT2, CF1, RES	2.2 to 5.5	0.75VDD			VDD
Low level input voltage	VIL(1)	• Ports 0, 3 • Ports A, B, C • Port L	Output disabled	4.0 to 5.5	VSS		0.15VDD +0.4	V	
			• Port 1 • Ports 71 to 73 • Port 70 port input/interrupt side	• Output disabled • When INT1VTSL=0 (P71 only)	2.2 to 4.0	VSS			0.2VDD
					4.0 to 5.5	VSS			0.1VDD +0.4
				• Output disabled • When INT1VTSL=1	2.2 to 4.0	VSS			0.2VDD
					2.2 to 5.5	VSS			0.45VDD
					2.2 to 5.5	VSS			0.8VDD -1.0
XT1, XT2, CF1, RES	2.2 to 5.5	VSS		0.25VDD					
Instruction cycle time (Note 2-2)	tCYC			3.0 to 5.5	0.237		200	μs	
				2.5 to 5.5	0.356		200		
				2.2 to 5.5	0.712		200		
External system clock frequency	FEXCF(1)	CF1	• CF2 pin open • System clock frequency division ratio=1/1 • External system clock DUTY=50±5%	3.0 to 5.5	0.1		12	MHz	
				2.5 to 5.5	0.1		8		
				2.2 to 5.5	0.1		4		
			• CF2 pin open • System clock frequency division ratio=1/2	3.0 to 5.5	0.2		24.4		
				2.5 to 5.5	0.2		16		
				2.2 to 5.5	0.2		8		

Note 2-1: VDD must be held greater than or equal to 3.0V in the flash ROM onboard programming mode.

Note 2-2: Relationship between tCYC and oscillation frequency is 3/FmCF at a division ratio of 1/1 and 6/FmCF at a division ratio of 1/2.

Continued on next page.

# LC87F7J32A

Continued from preceding page.

Parameter	Symbol	Pin/Remarks	Conditions	Specification				
				V <sub>DD</sub> [V]	min	typ	max	unit
Oscillation frequency range (Note 2-3)	FmCF(1)	CF1, CF2	<ul style="list-style-type: none"> <li>• 12MHz ceramic oscillation</li> <li>• See figure 1.</li> </ul>	3.0 to 5.5		12		MHz
	FmCF(2)	CF1, CF2	<ul style="list-style-type: none"> <li>• 8MHz ceramic oscillation</li> <li>• See figure 1.</li> </ul>	2.5 to 5.5		8		
	FmCF(3)	CF1, CF2	<ul style="list-style-type: none"> <li>• 4MHz ceramic oscillation</li> <li>• See figure 1.</li> </ul>	2.2 to 5.5		4		
	FmRC		Internal RC oscillation	2.2 to 5.5	0.3	1.0	2.0	
	FmVMRC(1)		<ul style="list-style-type: none"> <li>• Frequency variable RC source oscillation</li> <li>• When VMRAJ2 to 0=4, VMFAJ2 to 0=0, VMSL4M=0</li> </ul>	2.2 to 5.5		10		
	FmVMRC(2)		<ul style="list-style-type: none"> <li>• Frequency variable RC source oscillation</li> <li>• When VMRAJ2 to 0=4, VMFAJ2 to 0=0, VMSL4M=1</li> </ul>	2.2 to 5.5		4		
	FsX'tal	XT1, XT2	<ul style="list-style-type: none"> <li>• 32.768kHz crystal oscillation</li> <li>• See figure 2.</li> </ul>	2.2 to 5.5		32.768		kHz
Frequency variable RC oscillation usable range	OpVMRC(1)		When VMSL4M=0	2.2 to 5.5	8	10	12	MHz
	OpVMRC(2)		When VMSL4M=1	2.2 to 5.5	3.5	4	4.5	
Frequency variable RC oscillation adjustment range	VmADJ(1)		Each step of VMRAJn (Wide range)	2.2 to 5.5	8	24	64	%
	VmADJ(2)		Each step of VMFAJn (Small range)	2.2 to 5.5	1	4	8	

Note 2-3: See Tables 1 and 2 for the oscillation constants.

## Electrical Characteristics at Ta = -40°C to +85°C, V<sub>SS1</sub> = V<sub>SS2</sub> = V<sub>SS3</sub> = 0V

Parameter	Symbol	Pin/Remarks	Conditions	Specification				
				V <sub>DD</sub> [V]	min	typ	max	unit
High level input current	I <sub>IH</sub> (1)	<ul style="list-style-type: none"> <li>• Ports 0, 1, 3, 7</li> <li>• Ports A, B, C</li> <li>• Port L</li> </ul>	<ul style="list-style-type: none"> <li>• Output disabled</li> <li>• Pull-up resistor off</li> <li>• V<sub>IN</sub>=V<sub>DD</sub> (including output Tr's off leakage current)</li> </ul>	2.2 to 5.5			1	μA
	I <sub>IH</sub> (2)	$\overline{RES}$	V <sub>IN</sub> =V <sub>DD</sub>	2.2 to 5.5			1	
	I <sub>IH</sub> (3)	XT1, XT2	<ul style="list-style-type: none"> <li>• For input port specification</li> <li>• V<sub>IN</sub>=V<sub>DD</sub></li> </ul>	2.2 to 5.5			1	
	I <sub>IH</sub> (4)	CF1	V <sub>IN</sub> =V <sub>DD</sub>	2.2 to 5.5			15	
Low level input current	I <sub>IL</sub> (1)	<ul style="list-style-type: none"> <li>• Ports 0, 1, 3, 7</li> <li>• Ports A, B, C</li> <li>• Port L</li> </ul>	<ul style="list-style-type: none"> <li>• Output disabled</li> <li>• Pull-up resistor off</li> <li>• V<sub>IN</sub>=V<sub>SS</sub> (including output Tr's off leakage current)</li> </ul>	2.2 to 5.5	-1			μA
	I <sub>IL</sub> (2)	$\overline{RES}$	V <sub>IN</sub> =V <sub>SS</sub>	2.2 to 5.5	-1			
	I <sub>IL</sub> (3)	XT1, XT2	<ul style="list-style-type: none"> <li>• For input port specification</li> <li>• V<sub>IN</sub>=V<sub>SS</sub></li> </ul>	2.2 to 5.5	-1			
	I <sub>IL</sub> (4)	CF1	V <sub>IN</sub> =V <sub>SS</sub>	2.2 to 5.5	-15			

Continued on next page.

# LC87F7J32A

Continued from preceding page.

Parameter	Symbol	Pin/Remarks	Conditions	Specification				
				V <sub>DD</sub> [V]	min	typ	max	unit
High level output voltage	V <sub>OH</sub> (1)	Ports 0, 1	I <sub>OH</sub> =-1mA	4.5 to 5.5	V <sub>DD</sub> -1			V
	V <sub>OH</sub> (2)		I <sub>OH</sub> =-0.4mA	3.0 to 5.5	V <sub>DD</sub> -0.4			
	V <sub>OH</sub> (3)		I <sub>OH</sub> =-0.2mA	2.2 to 5.5	V <sub>DD</sub> -0.4			
	V <sub>OH</sub> (4)	Ports 30, 31	I <sub>OH</sub> =-10mA	4.5 to 5.5	V <sub>DD</sub> -1.5			
	V <sub>OH</sub> (5)		I <sub>OH</sub> =-1.6mA	3.0 to 5.5	V <sub>DD</sub> -0.4			
	V <sub>OH</sub> (6)		I <sub>OH</sub> =-1mA	2.2 to 5.5	V <sub>DD</sub> -0.4			
	V <sub>OH</sub> (7)	Ports 71 to 73	I <sub>OH</sub> =-0.4mA	3.0 to 5.5	V <sub>DD</sub> -0.4			
	V <sub>OH</sub> (8)		I <sub>OH</sub> =-0.2mA	2.2 to 5.5	V <sub>DD</sub> -0.4			
	V <sub>OH</sub> (9)	Ports A, B, C	I <sub>OH</sub> =-1mA	4.5 to 5.5	V <sub>DD</sub> -1			
	V <sub>OH</sub> (10)		I <sub>OH</sub> =-0.4mA	3.0 to 5.5	V <sub>DD</sub> -0.4			
	V <sub>OH</sub> (11)		I <sub>OH</sub> =-0.2mA	2.2 to 5.5	V <sub>DD</sub> -0.4			
Low level output voltage	V <sub>OL</sub> (1)	Ports 0, 1	I <sub>OL</sub> =10mA	4.5 to 5.5			1.5	
	V <sub>OL</sub> (2)	Ports 3 (PWM function output mode)	I <sub>OL</sub> =1.6mA	3.0 to 5.5			0.4	
	V <sub>OL</sub> (3)		I <sub>OL</sub> =1mA	2.2 to 5.5			0.4	
	V <sub>OL</sub> (4)	Ports 3 (Port function output mode)	I <sub>OL</sub> =30mA	4.5 to 5.5			1.5	
	V <sub>OL</sub> (5)		I <sub>OL</sub> =5mA	3.0 to 5.5			0.4	
	V <sub>OL</sub> (6)		I <sub>OL</sub> =2.5mA	2.2 to 5.5			0.4	
	V <sub>OL</sub> (7)	• Port 7	I <sub>OL</sub> =1.6mA	3.0 to 5.5			0.4	
	V <sub>OL</sub> (8)	• XT2	I <sub>OL</sub> =1mA	2.2 to 5.5			0.4	
	V <sub>OL</sub> (9)	Ports A, B, C	I <sub>OL</sub> =1.6mA	3.0 to 5.5			0.4	
	V <sub>OL</sub> (10)		I <sub>OL</sub> =1mA	2.2 to 5.5			0.4	
LCD output voltage deviation	VODLS	S0 to S23	• I <sub>O</sub> =0mA • VLCD, 2/3VLCD, 1/3VLCD level output • See Fig. 8.	2.2 to 5.5	0		±0.2	
	VODLC	COM0 to COM3	• I <sub>O</sub> =0mA • VLCD, 2/3VLCD, 1/2VLCD, 1/3VLCD level output • See Fig. 8.	2.2 to 5.5	0		±0.2	
LCD bias resistor	RLCD(1)	Resistance per one bias resistor	See Fig. 8.	2.2 to 5.5		80	kΩ	
	RLCD(2)	Resistance per one bias resistor 1/2R mode	See Fig. 8.	2.2 to 5.5		40		
Resistance of pull-up MOS Tr.	R <sub>pu</sub> (1)	Ports 0, 1, 3, 7	V <sub>OH</sub> =0-9V <sub>DD</sub>	4.5 to 5.5	15	35		80
	R <sub>pu</sub> (2)	Ports A, B, C		2.2 to 5.5	18	50	150	
Hysteresis voltage	VHYS(1)	Ports 1, 7 RES		2.2 to 5.5		0.1V <sub>DD</sub>	V	
Pin capacitance	CP	All pins	For pins other than that under test: V <sub>IN</sub> =V <sub>SS</sub> f=1MHz T <sub>a</sub> =25°C	2.2 to 5.5		10	pF	



# LC87F7J32A

**Serial I/O Characteristics** at Ta = -40°C to +85°C, VSS1 = VSS2 = VSS3 = 0V

## 1. SIO0 Serial I/O Characteristics (Note 4-1-1)

Parameter		Symbol	Pin/Remarks	Conditions	V <sub>DD</sub> [V]	Specification						
						min	typ	max	unit			
Serial clock	Input clock	Frequency	tSCK(1)	SCK0(P12)	See Fig. 6.	2.2 to 5.5	2			tCYC		
		Low level pulse width	tSCKL(1)				1					
		High level pulse width	tSCKH(1)				1					
			tSCKHA(1)									
	Output clock	Frequency	tSCK(2)	SCK0(P12)	<ul style="list-style-type: none"> <li>• CMOS output selected</li> <li>• See Fig. 6.</li> </ul>	2.2 to 5.5	4/3			tSCK		
		Low level pulse width	tSCKL(2)				1/2					
High level pulse width		tSCKH(2)	1/2									
		tSCKHA(2)	<ul style="list-style-type: none"> <li>• Continuous data transmission/reception mode</li> <li>• CMOS output selected</li> <li>• See Fig. 6.</li> </ul>				tSCKH(2) +2tCYC	tSCKH(2) +(10/3) tCYC	tCYC			
Serial input	Data setup time	tsDI(1)	SB0(P11), SI0(P11)	<ul style="list-style-type: none"> <li>• Must be specified with respect to rising edge of SIOCLK</li> <li>• See Fig. 6.</li> </ul>	2.2 to 5.5	0.03						
	Data hold time	thDI(1)					2.2 to 5.5	0.03				
Serial output	Output clock	Output delay time	tdDO(1)	SO0(P10), SB0(P11)	<ul style="list-style-type: none"> <li>• Continuous data transmission/reception mode</li> <li>• (Note 4-1-3)</li> </ul>	2.2 to 5.5			(1/3)tCYC +0.05	μs		
			tdDO(2)				<ul style="list-style-type: none"> <li>• Synchronous 8-bit mode</li> <li>• (Note 4-1-3)</li> </ul>	2.2 to 5.5				1tCYC +0.05
			tdDO(3)				(Note 4-1-3)	2.2 to 5.5				(1/3)tCYC +0.15

Note 4-1-1: These specifications are theoretical values. Add margin depending on its use.

Note 4-1-2: To use serial-clock-input in continuous trans/rec mode, a time from SIORUN being set when serial clock is "H" to the first negative edge of the serial clock must be longer than tSCKHA.

Note 4-1-3: Must be specified with respect to falling edge of SIOCLK. Must be specified as the time to the beginning of output state change in open drain output mode. See Fig. 6.

# LC87F7J32A

## 2. SIO1 Serial I/O Characteristics (Note 4-2-1)

Parameter		Symbol	Pin/Remarks	Conditions	V <sub>DD</sub> [V]	Specification				
						min	typ	max	unit	
Serial clock	Input clock	Frequency	tSCK(3)	SCK1(P15)	See Fig.6.	2.2 to 5.5	2			tCYC
		Low level pulse width	tSCKL(3)				1			
		High level pulse width	tSCKH(3)				1			
	Output clock	Frequency	tSCK(4)	SCK1(P15)	<ul style="list-style-type: none"> <li>• CMOS output selected</li> <li>• See Fig. 6.</li> </ul>	2.2 to 5.5	2			tSCK
		Low level pulse width	tSCKL(4)				1/2			
		High level pulse width	tSCKH(4)				1/2			
Serial input	Data setup time	tsDI(2)	SB1(P14), S11(P14)	<ul style="list-style-type: none"> <li>• Must be specified with respect to rising edge of SIOCLK.</li> <li>• See Fig. 6.</li> </ul>	2.2 to 5.5	0.03				
	Data hold time	thDI(2)				2.2 to 5.5	0.03			
Serial output	Output delay time	tdDO(4)	SO1(P13), SB1(P14)	<ul style="list-style-type: none"> <li>• Must be specified with respect to falling edge of SIOCLK.</li> <li>• Must be specified as the time to the beginning of output state change in open drain output mode.</li> <li>• See Fig. 6.</li> </ul>	2.2 to 5.5			(1/3)tCYC +0.05	μs	

Note 4-2-1: These specifications are theoretical values. Add margin depending on its use.

### Pulse Input Conditions at Ta = -40°C to +85°C, V<sub>SS1</sub> = V<sub>SS2</sub> = V<sub>SS3</sub> = 0V

Parameter	Symbol	Pin/Remarks	Conditions	V <sub>DD</sub> [V]	Specification			
					min	typ	max	unit
High/low level pulse width	tPIH(1) tPIL(1)	INT0(P70), INT1(P71), INT2(P72), INT4(P30), INT5(P31)	<ul style="list-style-type: none"> <li>• Interrupt source flag can be set.</li> <li>• Event inputs for timer 0 or 1 are enabled.</li> </ul>	2.2 to 5.5	1			tCYC
	tPIH(2) tPIL(2)	INT3(P73) when noise filter time constant is 1/1	<ul style="list-style-type: none"> <li>• Interrupt source flag can be set.</li> <li>• Event inputs for timer 0 are enabled.</li> </ul>	2.2 to 5.5	2			
	tPIH(3) tPIL(3)	INT3(P73) when noise filter time constant is 1/32	<ul style="list-style-type: none"> <li>• Interrupt source flag can be set.</li> <li>• Event inputs for timer 0 are enabled.</li> </ul>	2.2 to 5.5	64			
	tPIH(4) tPIL(4)	INT3(P73) when noise filter time constant is 1/128	<ul style="list-style-type: none"> <li>• Interrupt source flag can be set.</li> <li>• Event inputs for timer 0 are enabled.</li> </ul>	2.2 to 5.5	256			
	tPIH(5) tPIL(5)	RMIN(P73)	Recognized by the infrared remote controller receiver circuit as a signal.	2.2 to 5.5	4			RMCK (Note5-1)
	tPIL(6)	$\overline{\text{RES}}$	Resetting is enabled.	2.2 to 5.5	200			μs

Note 5-1: Represents the period of the reference clock (1tCYC to 128tCYC or the source frequency of the subclock) for the infrared remote controller receiver circuit

## LC87F7J32A

### AD Converter Characteristics at $V_{SS1} = V_{SS2} = V_{SS3} = 0V$

#### <12bits AD Converter Mode at $T_a = -40$ to $+85^\circ C$ >

Parameter	Symbol	Pin/Remarks	Conditions	Specification				
				$V_{DD}[V]$	min	typ	max	unit
Resolution	N	AN0(V1) to AN2(V3), AN3(P00) to AN7(P04), AN8(P70), AN9(P71), AN10(XT1), AN11(XT2)		3.0 to 5.5		12		bit
Absolute accuracy	ET		(Note 6-1)	3.0 to 5.5			$\pm 16$	LSB
Conversion time	TCAD		• See Conversion time calculation formulas. (Note 6-2)	4.0 to 5.5	32		115	$\mu s$
				3.0 to 5.5	64		115	
Analog input voltage range	VAIN			3.0 to 5.5	$V_{SS}$		$V_{DD}$	V
Analog port input current	IAINH		$VAIN = V_{DD}$	3.0 to 5.5			1	$\mu A$
	IAINL	$VAIN = V_{SS}$	3.0 to 5.5	-1				

#### <8bits AD Converter Mode at $T_a = -40$ to $+85^\circ C$ >

Parameter	Symbol	Pin/Remarks	Conditions	Specification				
				$V_{DD}[V]$	min	typ	max	unit
Resolution	N	AN0(V1) to AN2(V3), AN3(P00) to AN7(P04), AN8(P70), AN9(P71), AN10(XT1), AN11(XT2)		3.0 to 5.5		8		bit
Absolute accuracy	ET		(Note 6-1)	3.0 to 5.5			$\pm 1.5$	LSB
Conversion time	TCAD		• See Conversion time calculation formulas. (Note 6-2)	4.0 to 5.5	20		90	$\mu s$
				3.0 to 5.5	40		90	
Analog input voltage range	VAIN			3.0 to 5.5	$V_{SS}$		$V_{DD}$	V
Analog port input current	IAINH		$VAIN = V_{DD}$	3.0 to 5.5			1	$\mu A$
	IAINL	$VAIN = V_{SS}$	3.0 to 5.5	-1				

Conversion time calculation formulas:

12bits AD Converter Mode:  $TCAD(\text{Conversion time}) = ((52 / (\text{division ratio})) + 2) \times (1/3) \times t_{CYC}$

8bits AD Converter Mode:  $TCAD(\text{Conversion time}) = ((32 / (\text{division ratio})) + 2) \times (1/3) \times t_{CYC}$

External oscillation ( $F_{mCF}$ )	Operating supply voltage range ( $V_{DD}$ )	System division ratio (SYSDIV)	Cycle time ( $t_{CYC}$ )	AD division ratio (ADDIV)	AD conversion time (TCAD)	
					12bit AD	8bit AD
CF-12MHz	4.0V to 5.5V	1/1	250ns	1/8	34.8 $\mu s$	21.5 $\mu s$
	3.0V to 5.5V	1/1	250ns	1/16	69.5 $\mu s$	42.8 $\mu s$
CF-8MHz	4.0V to 5.5V	1/1	375ns	1/8	52.2 $\mu s$	32.3 $\mu s$
	3.0V to 5.5V	1/1	375ns	1/16	104.3 $\mu s$	64.2 $\mu s$
CF-4MHz	3.0V to 5.5V	1/1	750ns	1/8	104.5 $\mu s$	64.5 $\mu s$

Note 6-1: The quantization error ( $\pm 1/2LSB$ ) must be excluded from the absolute accuracy. The absolute accuracy must be measured in the microcontroller's state in which no I/O operations occur at the pins adjacent to the analog input channel.

Note 6-2: The conversion time refers to the period from the time an instruction for starting a conversion process till the time the conversion results register(s) are loaded with a complete digital conversion value corresponding to the analog input value.

The conversion time is 2 times the normal-time conversion time when:

- The first AD conversion is performed in the 12-bit AD conversion mode after a system reset.
- The first AD conversion is performed after the AD conversion mode is switched from 8-bit to 12-bit conversion mode.

## LC87F7J32A

### Power-on reset (POR) Characteristics at Ta=-40 to +85°C, V<sub>SS1</sub>=V<sub>SS2</sub>=V<sub>SS3</sub>=0V

Parameter	Symbol	Pin/Remarks	Conditions	Specification				
				Option selected voltage	min	typ	max	unit
POR release voltage	PORR		• Select from option. (Note 7-1)	2.07V	1.95	2.07	2.19	V
				2.37V	2.25	2.37	2.49	
				2.87V	2.75	2.87	2.99	
				4.35V	4.21	4.35	4.49	
Detection voltage unknown state	POUKS		• See Fig. 7. (Note 7-2)			0.7	0.95	
Power supply rise time	PORIS		• Power supply rise time from 0V to 2.0V.				100	ms

Note7-1: The POR release level can be selected out of 4 levels only when the LVD reset function is disabled.

Note7-2: POR is in an unknown state before transistors start operation.

### Low voltage detection reset (LVD) Characteristics at Ta=-40 to +85°C, V<sub>SS1</sub>=V<sub>SS2</sub>=V<sub>SS3</sub>=0V

Parameter	Symbol	Pin/Remarks	Conditions	Specification				
				Option selected voltage	min.	typ.	max.	unit
LVD reset voltage (Note 8-2)	LVDET		• Select from option. (Note 8-1) (Note 8-3) • See Fig. 8.	2.31V	2.21	2.31	2.41	V
				2.81V	2.71	2.81	2.91	
				4.28V	4.18	4.28	4.38	
LVD hysteresys width	LVHYS		• See Fig. 8.	2.31V		55		mV
				2.81V		60		
				4.28V		65		
Detection voltage unknown state	LVUKS		• See Fig. 8. (Note 8-4)			0.7	0.95	V
Low voltage detection minimum width (Reply sensitivity)	TLVDW		• See Fig. 9.		0.2			ms

Note8-1: The LVD reset level can be selected out of 3 levels only when the LVD reset function is enabled.

Note8-2: LVD reset voltage specification values do not include hysteresis voltage.

Note8-3: LVD reset voltage may exceed its specification values when port output state changes and/or when a large current flows through port.

Note8-4: LVD is in an unknown state before transistors start operation.

# LC87F7J32A

## Consumption Current Characteristics at Ta = -40°C to +85°C, VSS1 = VSS2 = VSS3 = 0V

Parameter	Symbol	Pin/ Remarks	Conditions	Specification				
				VDD[V]	min	typ	max	unit
Normal mode consumption current (Note 9-1)	IDDOP(1)	VDD1 =VDD2 =VDD3	<ul style="list-style-type: none"> <li>FmCF=12MHz ceramic oscillation mode</li> <li>FmX'tal=32.768kHz crystal oscillation mode</li> <li>System clock set to 12MHz side</li> <li>Internal RC oscillation stopped.</li> <li>Frequency variable RC oscillation stopped.</li> <li>1/1 frequency division ratio</li> </ul>	4.5 to 5.5		8.5	23	mA
	IDDOP(2)			3.0 to 3.6		4.8	13	
	IDDOP(3)		<ul style="list-style-type: none"> <li>FmCF=8MHz ceramic oscillation mode</li> <li>FmX'tal=32.768kHz crystal oscillation mode</li> <li>System clock set to 8MHz side</li> <li>Internal RC oscillation stopped.</li> <li>Frequency variable RC oscillation stopped.</li> <li>1/1 frequency division ratio</li> </ul>	4.5 to 5.5		6.9	19	
	IDDOP(4)			3.0 to 3.6		3.9	11	
	IDDOP(5)		<ul style="list-style-type: none"> <li>FmCF=4MHz ceramic oscillation mode</li> <li>FmX'tal=32.768kHz crystal oscillation mode</li> <li>System clock set to 4MHz side</li> <li>Internal RC oscillation stopped.</li> <li>Frequency variable RC oscillation stopped.</li> <li>1/2 frequency division ratio</li> </ul>	4.5 to 5.5		2.4	6.6	
	IDDOP(6)			3.0 to 3.6		1.3	3.5	
	IDDOP(7)		<ul style="list-style-type: none"> <li>FmCF=0Hz (oscillation stopped)</li> <li>FmX'tal=32.768kHz crystal oscillation mode</li> <li>System clock set to internal RC oscillation</li> <li>Frequency variable RC oscillation stopped.</li> <li>1/2 frequency division ratio</li> </ul>	4.5 to 5.5		0.7	3.3	
	IDDOP(8)			3.0 to 3.6		0.4	1.9	
	IDDOP(9)		<ul style="list-style-type: none"> <li>FmCF=0Hz (oscillation stopped)</li> <li>FmX'tal=32.768kHz crystal oscillation mode</li> <li>Internal RC oscillation stopped.</li> <li>System clock set to 10MHz with frequency variable RC oscillation</li> <li>1/1 frequency division ratio</li> </ul>	4.5 to 5.5		7.8	21	
	IDDOP(10)			3.0 to 3.6		4.5	12	
	IDDOP(11)		<ul style="list-style-type: none"> <li>FmCF=0Hz (oscillation stopped)</li> <li>FmX'tal=32.768kHz crystal oscillation mode</li> <li>Internal RC oscillation stopped.</li> <li>System clock set to 4MHz with frequency variable RC oscillation</li> <li>1/1 frequency division ratio</li> </ul>	4.5 to 5.5		3.6	10	
	IDDOP(12)			3.0 to 3.6		2.8	7.7	
	IDDOP(13)		<ul style="list-style-type: none"> <li>FmCF=0Hz (oscillation stopped)</li> <li>FmX'tal=32.768kHz crystal oscillation mode</li> <li>System clock set to 32.768kHz side</li> <li>Internal RC oscillation stopped.</li> <li>Frequency variable RC oscillation stopped.</li> <li>1/2 frequency division ratio</li> </ul>	4.5 to 5.5		35	120	
	IDDOP(14)			3.0 to 3.6		18	72	
	IDDOP(15)		<ul style="list-style-type: none"> <li>HALT mode</li> <li>FmCF=12MHz ceramic oscillation mode</li> <li>FmX'tal=32.768kHz crystal oscillation mode</li> <li>System clock set to 12MHz side</li> <li>Internal RC oscillation stopped.</li> <li>Frequency variable RC oscillation stopped.</li> <li>1/1 frequency division ratio</li> </ul>	4.5 to 5.5		3.8	9.2	
	IDDOP(16)			3.0 to 3.6		2.0	5.0	
	IDDOP(17)		<ul style="list-style-type: none"> <li>HALT mode</li> <li>FmCF=8MHz ceramic oscillation mode</li> <li>FmX'tal=32.768kHz crystal oscillation mode</li> <li>System clock set to 8MHz side</li> <li>Internal RC oscillation stopped.</li> <li>Frequency variable RC oscillation stopped.</li> <li>1/1 frequency division ratio</li> </ul>	4.5 to 5.5		2.8	7.7	
	IDDOP(18)			3.0 to 3.6		1.4	3.9	
	IDDOP(19)		<ul style="list-style-type: none"> <li>HALT mode</li> <li>FmCF=12MHz ceramic oscillation mode</li> <li>FmX'tal=32.768kHz crystal oscillation mode</li> <li>System clock set to 12MHz side</li> <li>Internal RC oscillation stopped.</li> <li>Frequency variable RC oscillation stopped.</li> <li>1/1 frequency division ratio</li> </ul>	4.5 to 5.5		3.8	9.2	
IDDOP(20)	3.0 to 3.6			2.0	5.0			
HALT mode consumption current (Note 9-1)	IDDHALT(1)		<ul style="list-style-type: none"> <li>HALT mode</li> <li>FmCF=12MHz ceramic oscillation mode</li> <li>FmX'tal=32.768kHz crystal oscillation mode</li> <li>System clock set to 12MHz side</li> <li>Internal RC oscillation stopped.</li> <li>Frequency variable RC oscillation stopped.</li> <li>1/1 frequency division ratio</li> </ul>	4.5 to 5.5		3.8	9.2	mA
	IDDHALT(2)			3.0 to 3.6		2.0	5.0	
	IDDHALT(3)		<ul style="list-style-type: none"> <li>HALT mode</li> <li>FmCF=8MHz ceramic oscillation mode</li> <li>FmX'tal=32.768kHz crystal oscillation mode</li> <li>System clock set to 8MHz side</li> <li>Internal RC oscillation stopped.</li> <li>Frequency variable RC oscillation stopped.</li> <li>1/1 frequency division ratio</li> </ul>	4.5 to 5.5		2.8	7.7	
	IDDHALT(4)			3.0 to 3.6		1.4	3.9	
	IDDHALT(5)		<ul style="list-style-type: none"> <li>HALT mode</li> <li>FmCF=12MHz ceramic oscillation mode</li> <li>FmX'tal=32.768kHz crystal oscillation mode</li> <li>System clock set to 12MHz side</li> <li>Internal RC oscillation stopped.</li> <li>Frequency variable RC oscillation stopped.</li> <li>1/1 frequency division ratio</li> </ul>	2.5 to 3.0		1.1	3.1	

Note 9-1: The consumption current value includes none of the currents that flow into the output Tr and internal pull-up resistors.

Continued on next page.

# LC87F7J32A

Continued from preceding page.

Parameter	Symbol	Pin/ Remarks	Conditions	Specification				
				V <sub>DD</sub> [V]	min	typ	max	unit
HALT mode consumption current (Note 9-1)	IDDHALT(6)	V <sub>DD1</sub> =V <sub>DD2</sub> =V <sub>DD3</sub>	<ul style="list-style-type: none"> <li>• HALT mode</li> <li>• FmCF=4MHz ceramic oscillation mode</li> <li>• FmX'tal=32.768kHz crystal oscillation mode</li> <li>• System clock set to 4MHz side</li> <li>• Internal RC oscillation stopped.</li> <li>• Frequency variable RC oscillation stopped.</li> <li>• 1/2 frequency division ratio</li> </ul>	4.5 to 5.5		1.2	3.3	mA
	IDDHALT(7)			3.0 to 3.6		0.6	1.7	
	IDDHALT(8)			2.2 to 3.0		0.4	1.2	
	IDDHALT(9)		<ul style="list-style-type: none"> <li>• HALT mode</li> <li>• FmCF=0Hz (oscillation stopped)</li> <li>• FmX'tal=32.768kHz crystal oscillation mode</li> <li>• System clock set to internal RC oscillation</li> <li>• Frequency variable RC oscillation stopped.</li> <li>• 1/2 frequency division ratio</li> </ul>	4.5 to 5.5		0.40	1.89	
	IDDHALT(10)			3.0 to 3.6		0.20	0.83	
	IDDHALT(11)			2.2 to 3.0		0.15	0.69	
	IDDHALT(12)		<ul style="list-style-type: none"> <li>• HALT mode</li> <li>• FmCF=0Hz (oscillation stopped)</li> <li>• FmX'tal=32.768kHz crystal oscillation mode</li> <li>• Internal RC oscillation stopped.</li> <li>• System clock set to 10MHz with frequency variable RC oscillation</li> <li>• 1/1 frequency division ratio</li> </ul>	4.5 to 5.5		3.3	9.0	
	IDDHALT(13)			3.0 to 3.6		1.6	4.4	
	IDDHALT(14)			4.5 to 5.5		1.7	4.6	
	IDDHALT(15)		<ul style="list-style-type: none"> <li>• HALT mode</li> <li>• FmCF=0Hz (oscillation stopped)</li> <li>• FmX'tal=32.768kHz crystal oscillation mode</li> <li>• Internal RC oscillation stopped.</li> <li>• System clock set to 4MHz with frequency variable RC oscillation</li> <li>• 1/1 frequency division ratio</li> </ul>	3.0 to 3.6		0.8	2.2	
	IDDHALT(16)			2.2 to 3.0		0.6	1.7	
	IDDHALT(17)			4.5 to 5.5		22	82	
	IDDHALT(18)		<ul style="list-style-type: none"> <li>• HALT mode</li> <li>• FmCF=0Hz (oscillation stopped)</li> <li>• FmX'tal=32.768kHz crystal oscillation mode</li> <li>• System clock set to 32.768kHz side</li> <li>• Internal RC oscillation stopped.</li> <li>• Frequency variable RC oscillation stopped.</li> <li>• 1/2 frequency division ratio</li> </ul>	3.0 to 3.6		9	33	
IDDHALT(19)	2.2 to 3.0			6	26			
HOLD mode consumption current	IDDHOLD(1)	V <sub>DD1</sub>	<ul style="list-style-type: none"> <li>• HOLD mode</li> <li>• CF1=V<sub>DD</sub> or open (External clock mode)</li> </ul>	4.5 to 5.5		0.05	22	μA
	IDDHOLD(2)			3.0 to 3.6		0.03	13	
	IDDHOLD(3)			2.2 to 3.0		0.02	9	
	IDDHOLD(4)		<ul style="list-style-type: none"> <li>• HOLD mode</li> <li>• CF1=V<sub>DD</sub> or open (External clock mode)</li> <li>• LVD option selected</li> </ul>	4.5 to 5.5		3.5	25	
	IDDHOLD(5)			3.0 to 3.6		2.2	15	
	IDDHOLD(6)			2.2 to 3.0		2.0	10	
Timer HOLD mode consumption current	IDDHOLD(7)	V <sub>DD1</sub>	<ul style="list-style-type: none"> <li>• Timer HOLD mode</li> <li>• CF1=V<sub>DD</sub> or open (External clock mode)</li> <li>• FmX'tal=32.768kHz crystal oscillation mode</li> </ul>	4.5 to 5.5		19	65	
	IDDHOLD(8)			3.0 to 3.6		7.0	31	
	IDDHOLD(9)			2.2 to 3.0		4.5	17	

Note 9-1: The consumption current value includes none of the currents that flow into the output Tr and internal pull-up resistors.

## F-ROM Programming Characteristics at Ta = +10°C to +55°C, V<sub>SS1</sub> = V<sub>SS2</sub> = V<sub>SS3</sub> = 0V

Parameter	Symbol	Pin/Remarks	Conditions	Specification				
				V <sub>DD</sub> [V]	min	typ	max	unit
Onboard programming current	IDDFW(1)	V <sub>DD1</sub>	<ul style="list-style-type: none"> <li>• 128-byte programming</li> <li>• Erasing current included</li> </ul>	3.0 to 5.5		5	10	mA
Programming time	tFW(1)		Erasing time	3.0 to 5.5		20	30	ms
			Programming time			40	60	μs

# LC87F7J32A

## UART (Full Duplex) Operating Conditions at Ta = -40 to +85°C, VSS1 = VSS2 = VSS3 = 0V

Parameter	Symbol	Pin/Remarks	Conditions	Specification				
				V <sub>DD</sub> [V]	min	typ	max	unit
Transfer rate	UBR	UTX(S0), URX(S1)		2.2 to 5.5	16/3		8192/3	tCYC

Data length: 7/8/9 bits (LSB first)

Stop bits: 1 bit (2-bit in continuous data transmission)

Parity bits: None

Example of 8-bit Data Transmission Mode Processing (Transmit Data=55H)

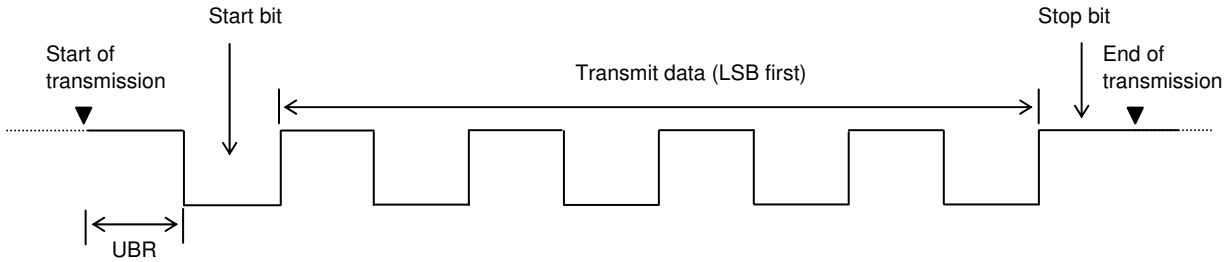

Example of 8-bit Data Reception Mode Processing (Receive Data=55H)

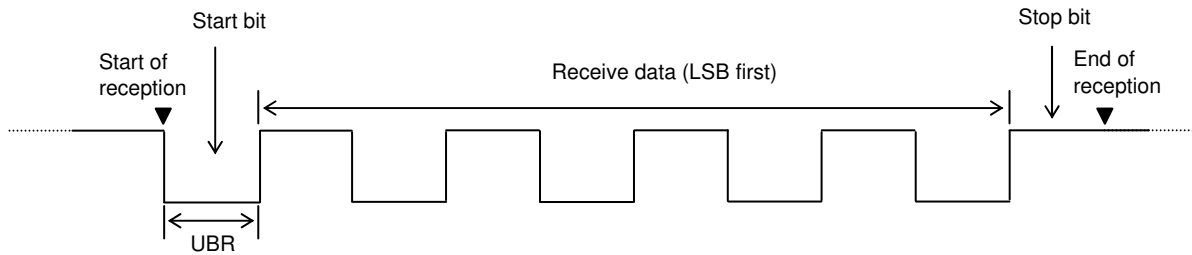

### Characteristics of a Sample Main System Clock Oscillation Circuit

Given below are the characteristics of a sample main system clock oscillation circuit that are measured using a Our designated oscillation characteristics evaluation board and external components with circuit constant values with which the oscillator vendor confirmed normal and stable oscillation.

Table 1 Characteristics of a Sample Main System Clock Oscillator Circuit with a Ceramic Oscillator

Nominal Frequency	Vendor Name	Oscillator Name	Circuit Constant				Operating Voltage Range [V]	Oscillation Stabilization Time		Remarks
			C1	C2	Rf1	Rd1		typ	max	
			[pF]	[pF]	[Ω]	[Ω]		[ms]	[ms]	
12MHz	MURATA	CSTCE12M0G52-R0	(10)	(10)	Open	470	3.0 to 5.5	0.05	0.15	Internal C1, C2
8MHz	MURATA	CSTCE8M00G52-R0	(10)	(10)	Open	2.2k	2.7 to 5.5	0.05	0.15	Internal C1, C2
		CSTLS8M00G53-B0	(15)	(15)	Open	680	2.5 to 5.5	0.05	0.15	
4MHz	MURATA	CSTCR4M00G53-R0	(15)	(15)	Open	3.3k	2.2 to 5.5	0.05	0.15	Internal C1, C2
		CSTLS4M00G53-B0	(15)	(15)	Open	3.3k	2.2 to 5.5	0.05	0.15	

The oscillation stabilization time refers to the time interval that is required for the oscillation to get stabilized after V<sub>DD</sub> goes above the operating voltage lower limit (see Figure 4).

**Characteristics of a Sample Subsystem Clock Oscillator Circuit**

Given below are the characteristics of a sample subsystem clock oscillation circuit that are measured using a Our designated oscillation characteristics evaluation board and external components with circuit constant values with which the oscillator vendor confirmed normal and stable oscillation.

Table 2 Characteristics of a Sample Subsystem Clock Oscillator Circuit with a Crystal Oscillator

Nominal Frequency	Vendor Name	Oscillator Name	Circuit Constant				Operating Voltage Range [V]	Oscillation Stabilization Time		Remarks
			C3 [pF]	C4 [pF]	Rf2 [ $\Omega$ ]	Rd2 [ $\Omega$ ]		typ [s]	max [s]	
32.768kHz	EPSON TOYOKOMU	MC-306	18	18	Open	560	2.2 to 5.5	1.4	3.0	Applicable CL value= 12.5pF

The oscillation stabilization time refers to the time interval that is required for the oscillation to get stabilized after the instruction for starting the subclock oscillation circuit is executed and to the time interval that is required for the oscillation to get stabilized after the HOLD mode is reset (see Figure 4).

Note: The components that are involved in oscillation should be placed as close to the IC and to one another as possible because they are vulnerable to the influences of the circuit pattern.

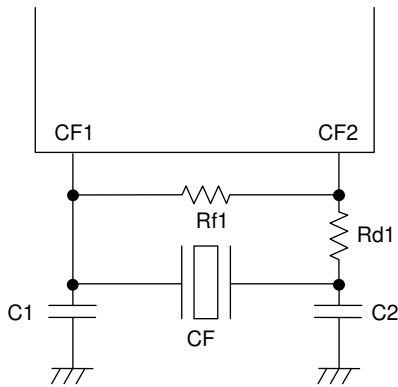

Figure 1 CF Oscillator Circuit

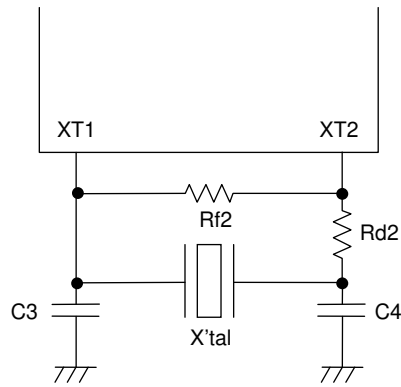

Figure 2 XT Oscillator Circuit

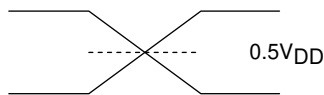
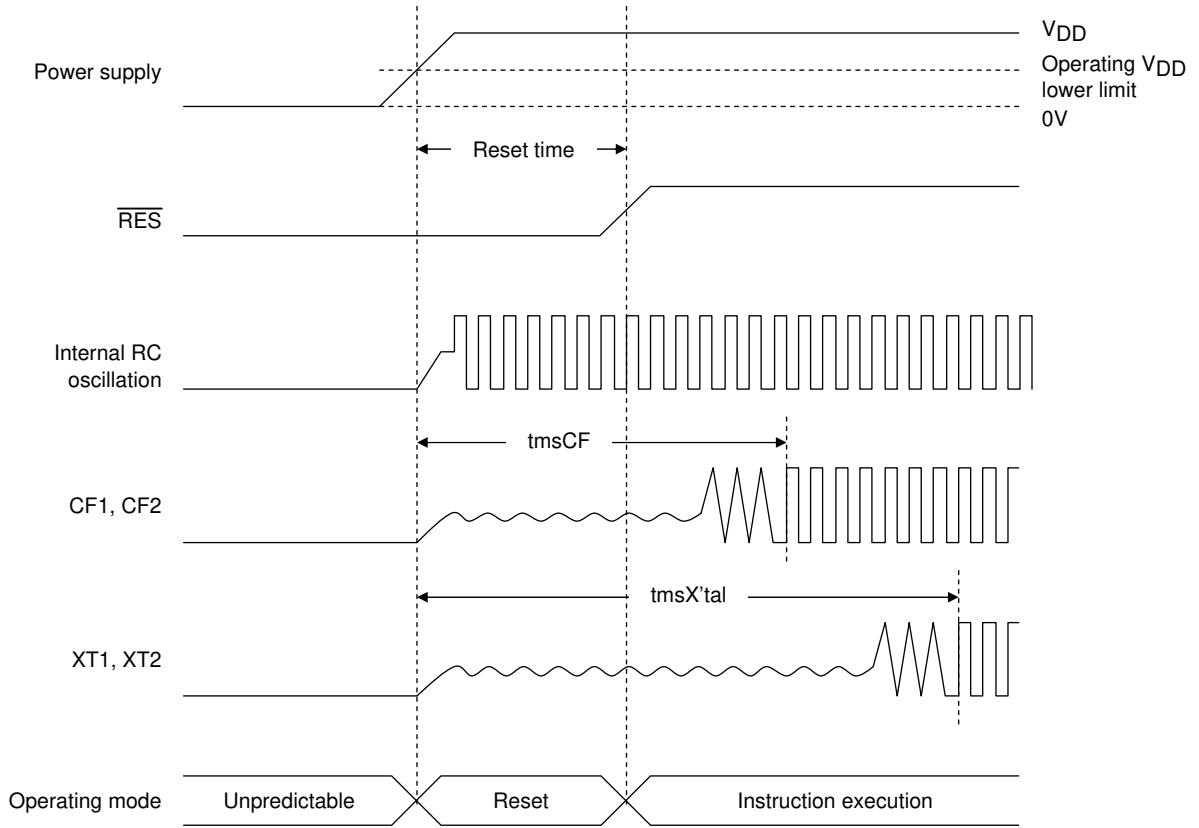
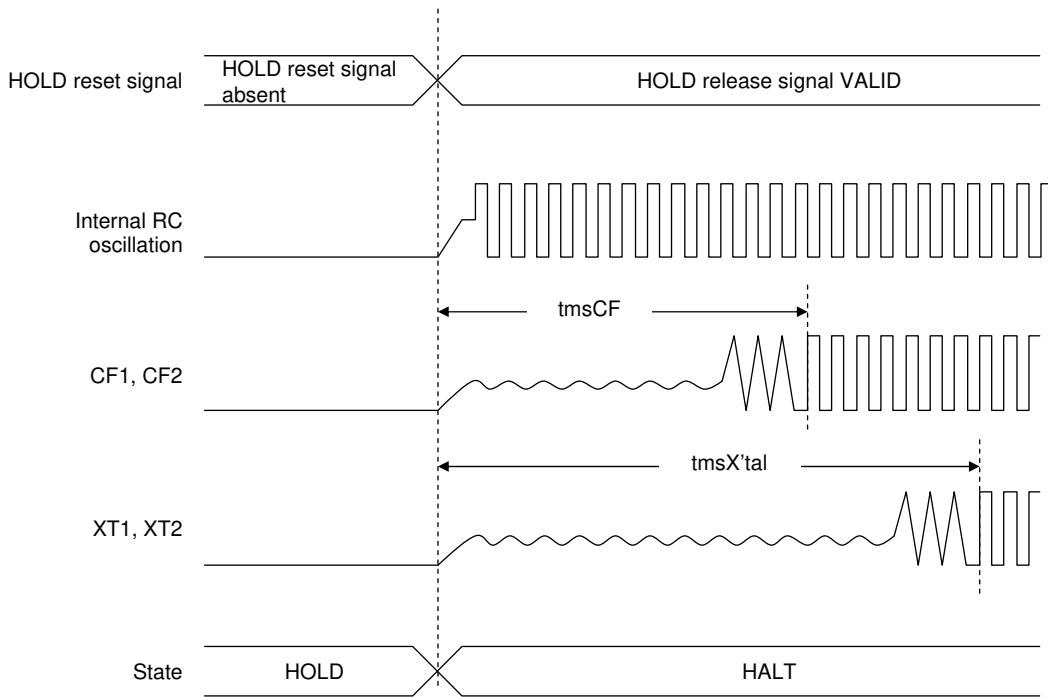

Figure 3 AC Timing Measurement Point





Reset Time and Oscillation Stabilization Time



HOLD Reset Signal and Oscillation Stabilization Time

Figure 4 Oscillation Stabilization Times

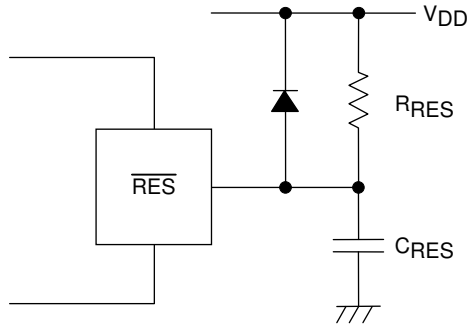

Note:  
External circuits for reset may vary depending on the usage of POR and LVD. Please refer to the user's manual for more information.

Figure 5 Reset Circuit

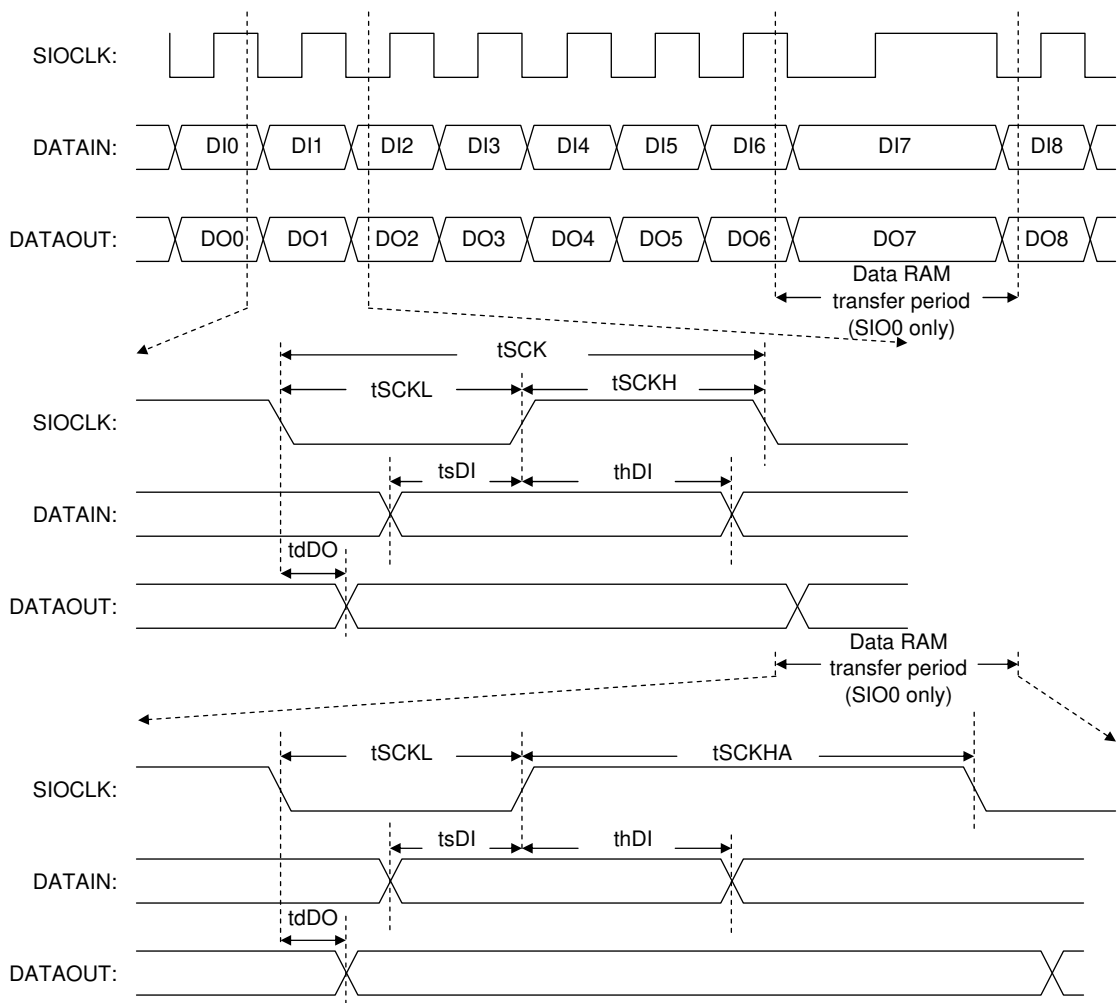

Figure 6 Serial I/O Waveforms

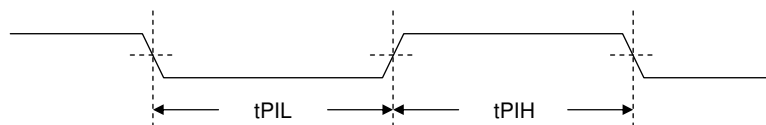

Figure 7 Pulse Input Timing Signal Waveform

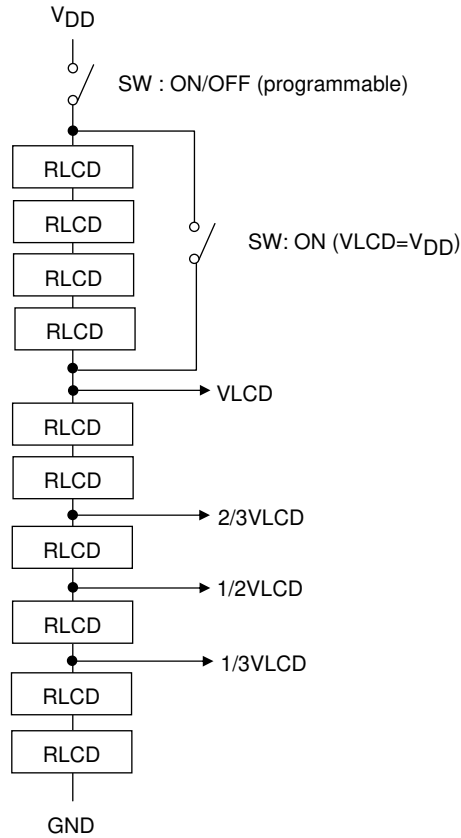

Figure 8 LCD Bias Resistors

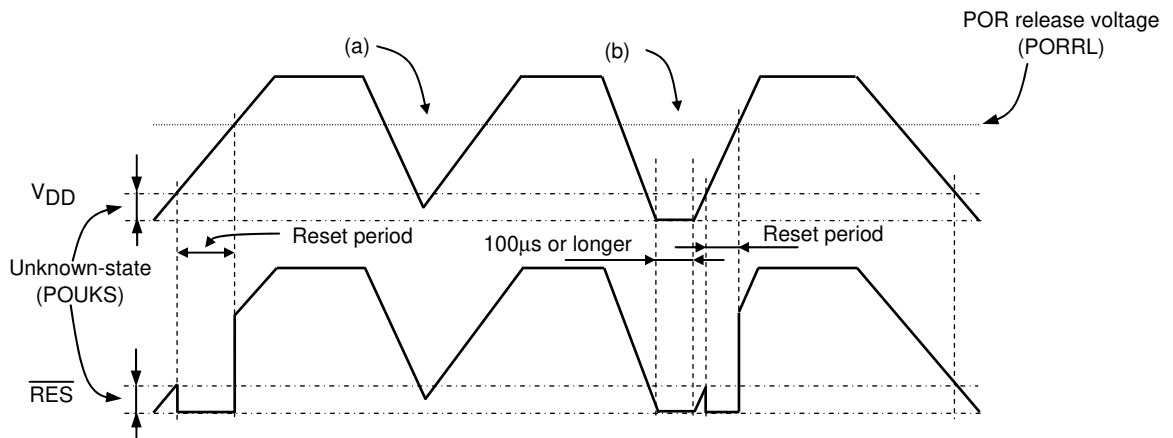

Figure 9 Waveform observed when only POR is used (LVD not used)  
(RESET pin: Pull-up resistor  $R_{RES}$  only)

- The POR function generates a reset only when power is turned on starting at the  $V_{SS}$  level.
- No stable reset will be generated if power is turned on again when the power level does not go down to the  $V_{SS}$  level as shown in (a). If such a case is anticipated, use the LVD function together with the POR function or implement an external reset circuit.
- A reset is generated only when the power level goes down to the  $V_{SS}$  level as shown in (b) and power is turned on again after this condition continues for 100µs or longer.

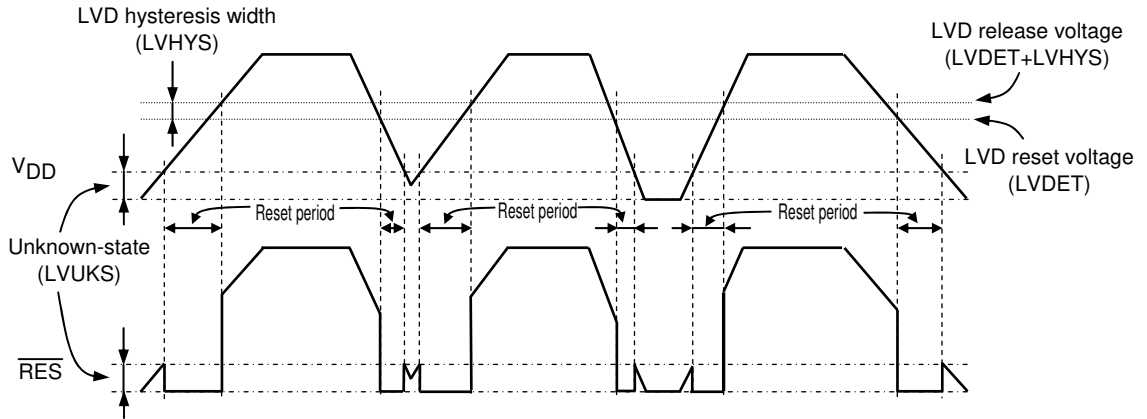

Figure 10 Waveform observed when both POR and LVD functions are used (RESET pin: Pull-up resistor RRES only)

- Resets are generated both when power is turned on and when the power level lowers.
- A hysteresis width (LVHYS) is provided to prevent the repetitions of reset release and entry cycles near the detection level.

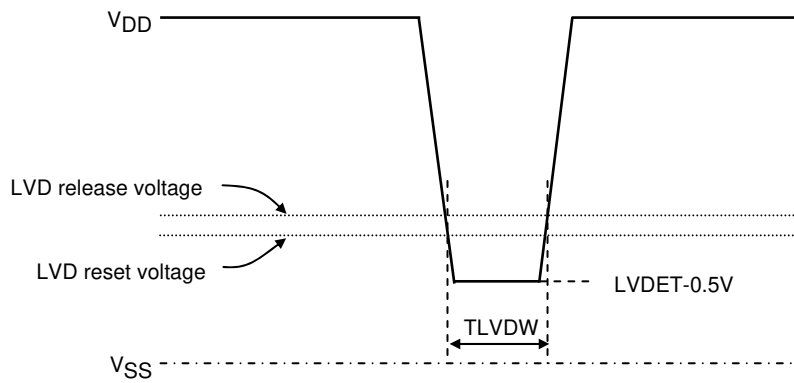

Figure 11 Low voltage detection minimum width (Example of momentary power loss/Voltage variation waveform)

ON Semiconductor and the ON logo are registered trademarks of Semiconductor Components Industries, LLC (SCILLC). SCILLC owns the rights to a number of patents, trademarks, copyrights, trade secrets, and other intellectual property. A listing of SCILLC's product/patent coverage may be accessed at [www.onsemi.com/site/pdf/Patent-Marking.pdf](http://www.onsemi.com/site/pdf/Patent-Marking.pdf). SCILLC reserves the right to make changes without further notice to any products herein. SCILLC makes no warranty, representation or guarantee regarding the suitability of its products for any particular purpose, nor does SCILLC assume any liability arising out of the application or use of any product or circuit, and specifically disclaims any and all liability, including without limitation special, consequential or incidental damages. "Typical" parameters which may be provided in SCILLC data sheets and/or specifications can and do vary in different applications and actual performance may vary over time. All operating parameters, including "Typicals" must be validated for each customer application by customer's technical experts. SCILLC does not convey any license under its patent rights nor the rights of others. SCILLC products are not designed, intended, or authorized for use as components in systems intended for surgical implant into the body, or other applications intended to support or sustain life, or for any other application in which the failure of the SCILLC product could create a situation where personal injury or death may occur. Should Buyer purchase or use SCILLC products for any such unintended or unauthorized application, Buyer shall indemnify and hold SCILLC and its officers, employees, subsidiaries, affiliates, and distributors harmless against all claims, costs, damages, and expenses, and reasonable attorney fees arising out of, directly or indirectly, any claim of personal injury or death associated with such unintended or unauthorized use, even if such claim alleges that SCILLC was negligent regarding the design or manufacture of the part. SCILLC is an Equal Opportunity/Affirmative Action Employer. This literature is subject to all applicable copyright laws and is not for resale in any manner.