

# Features

# Regulated Converters

- 150W DC/DC converter in Half Brick format
- 9-75VDC ultra wide input voltage range
- 2.5kVDC/1 minute insulation
- Efficiency up to 89.5%
- -40°C to +110°C baseplate temperature range
- Fully protected with UVLO, SCP, OVP, and OLP



## REC150H-UW

**150 Watt  
Half Brick  
Single Output**



### Description

The REC150H-UW is a half-brick encapsulated DC/DC converter which delivers up to 150W. Its wide input voltage range makes it flexible to install on 12, 24, and 48V rails, and it is especially suitable for 12V, 24V or 48V battery supplies. The tightly-regulated, fully-protected output voltage options are 12V, 24V, 28V, 48V, or 54V - all trimmable over a +/-10% range. Aside from the common 12, 24, and 48V output voltages, additional 28V for avionic systems and 54V for PoE applications are standard.

### Selection Guide

Part Number	Input Voltage Range [VDC]	nom. Output Voltage [VDC]	Output Current max. [A]	Efficiency typ. <sup>(1)</sup> [%]	Max. Capacitive Load <sup>(2)</sup> [µF]
REC150H-4812SUW	9 - 75	12	12.5	89.5	5000
REC150H-4824SUW	9 - 75	24	6.25	88.5	2000
REC150H-4828SUW	9 - 75	28	5.357	89	1500
REC150H-4848SUW	9 - 75	48	3.125	88.5	1000
REC150H-4854SUW	9 - 75	54	2.778	89	1000

#### Notes:

Note1: Efficiency is tested at nominal input and full load at +25°C ambient

Note2: Maximum capacitive load is tested at V<sub>IN</sub>=9VDC and constant resistive load

IEC/EN62368-1 pending  
UL62368-1 pending  
CAN/CSA-C22.2 No. 62368-1-19 pending

### Model Numbering

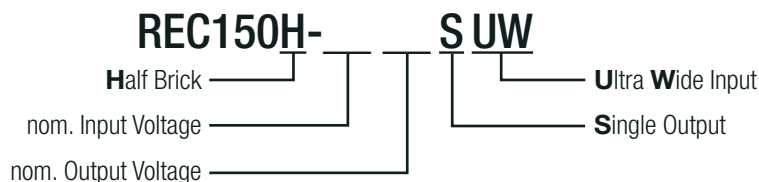

### Specifications (measured @ Ta= 25°C, nom. Vin, full load and after warm-up unless otherwise stated)

BASIC CHARACTERISTICS				
Parameter	Condition	Min.	Typ.	Max.
Internal Input Filter				Pi type
Input Voltage Range	nom. V <sub>IN</sub> = 48VDC	9VDC	48VDC	75VDC
Input Surge Voltage	100ms max.			100VDC
Under Voltage Lockout (UVLO)	0% to 100%		8VDC	
Quiescent Current	nom. V <sub>OUT</sub> = 12, 24, 28VDC			35mA
	nom. V <sub>OUT</sub> = 48, 54VDC			75mA
Minimum Load		0%		
Output Voltage Trimming				±10%
ON/OFF CTRL	DC-DC ON	Open or 3VDC < V <sub>CTRL</sub> < 12VDC		
	DC-DC OFF	Short or 0VDC < V <sub>CTRL</sub> < 1.2VDC		

continued on next page

**Specifications** (measured @  $T_a = 25^\circ\text{C}$ , nom.  $V_{in}$ , full load and after warm-up unless otherwise stated)

Parameter	Condition	Min.	Typ.	Max.
Start-up Time		200ms		400ms
Internal Operating Frequency			200kHz	
Output Ripple and Noise	20MHz BW	nom. $V_{OUT} = 12\text{VDC}$		100mVp-p
		others		240mVp-p

**Efficiency vs. Load**  
(@ nom.  $V_{in} = 48\text{VDC}$ )

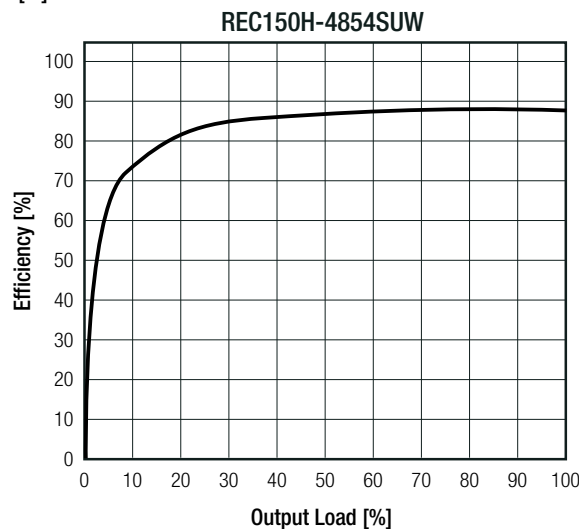
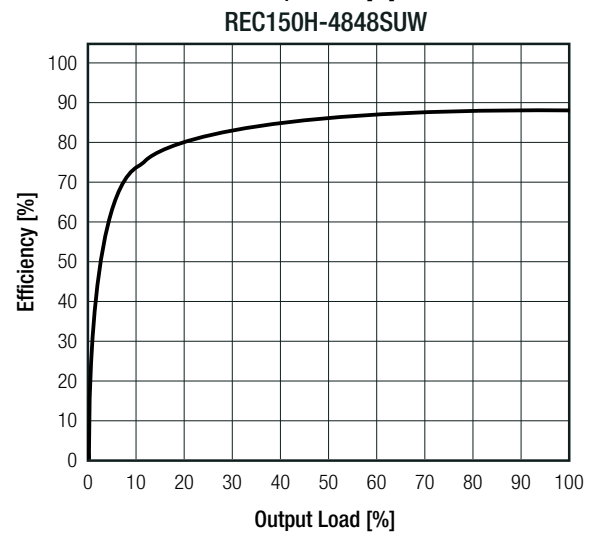
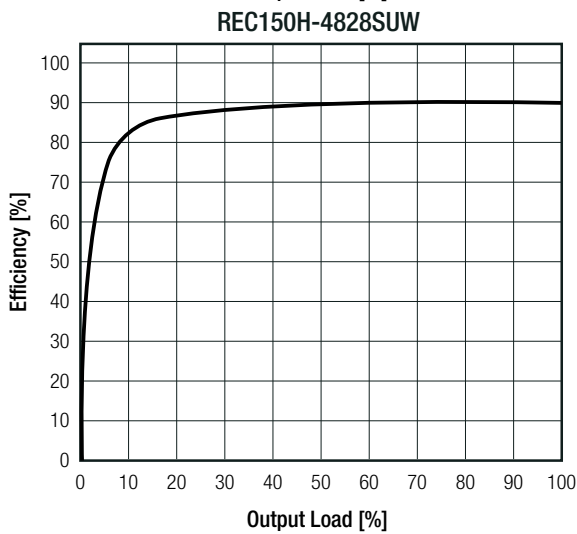
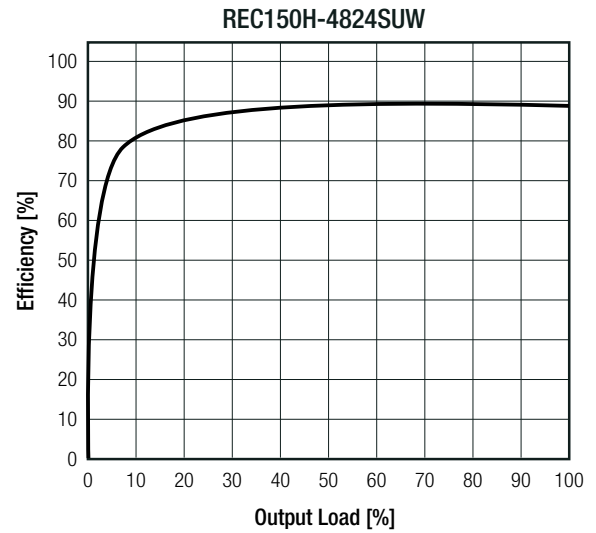
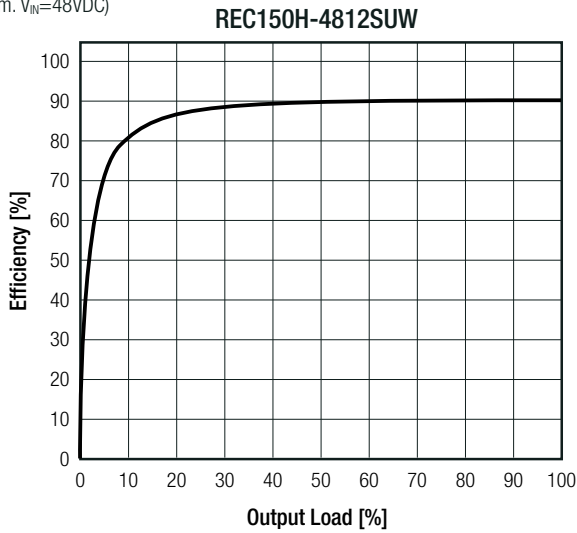

Specifications (measured @ Ta= 25°C, nom. Vin, full load and after warm-up unless otherwise stated)

**OUTPUT VOLTAGE TRIMMING**

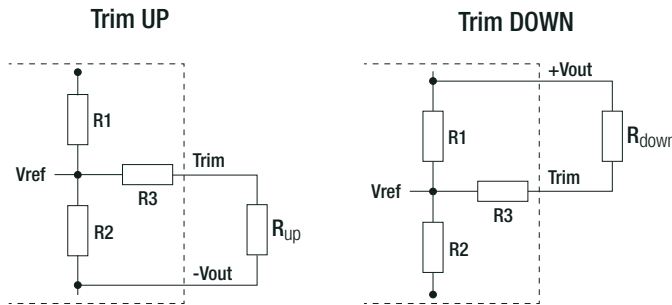

Vout <sub>nom</sub>	R <sub>1</sub> [Ω]	R <sub>2</sub> [Ω]	R <sub>3</sub> [Ω]	V <sub>ref</sub> [VDC]
12VDC	38k	10k	68k	2.5
24VDC	86k		76k8	
28VDC	102k		76k8	
48VDC	182k		80k6	
54VDC	206k1		82k	

**Trim Calculation**

- Vout<sub>nom</sub> = nominal output voltage [VDC]
- Vout<sub>set</sub> = trimmed output voltage [VDC]
- V<sub>ref</sub> = reference voltage [VDC]
- R<sub>up</sub> = trim up resistor [Ω]
- R<sub>down</sub> = trim down resistor [Ω]
- R<sub>1</sub>, R<sub>2</sub>, R<sub>3</sub> = internal resistors [Ω]
- k<sub>u</sub> = trim up factor (a) [ ]
- k<sub>d</sub> = trim down factor (b) [ ]

$$k_u = \left[ \frac{V_{ref}}{V_{out_{set}} - V_{ref}} \right] \times R_1$$

$$R_{up} = \left[ \frac{k_u \times R_2}{R_2 - k_u} \right] - R_3$$

$$k_d = \left[ \frac{V_{out_{set}} - V_{ref}}{V_{ref}} \right] \times R_2$$

$$R_{down} = \left[ \frac{k_d \times R_1}{R_1 - k_d} \right] - R_3$$

**Trim Up: Vout<sub>set</sub> = 26.4VDC**

Vout<sub>nom</sub> = 24V

$$k_u = \left[ \frac{2.5V}{26.4V - 2.5V} \right] \times 86k\Omega = 8k995\Omega$$

$$R_{up} = \left[ \frac{8.995k\Omega \times 10k\Omega}{10k\Omega - 8.995k\Omega} \right] - 76.8k\Omega = 12k7\Omega$$

**Trim down: Vout<sub>set</sub> = 21.6VDC**

Vout<sub>nom</sub> = 24V

$$k_d = \left[ \frac{21.6 - 2.5V}{2.5V} \right] \times 10k\Omega = 76k4\Omega$$

$$R_{down} = \left[ \frac{76.4k\Omega \times 86k\Omega}{86k\Omega - 76.4k\Omega} \right] - 76.8k\Omega = 684k4\Omega$$

**ON/OFF CTRL**

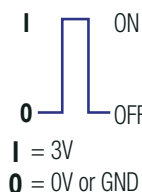
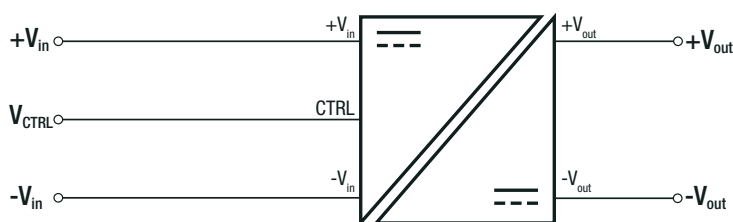

**DC-DC ON:** Open or 3VDC < V<sub>CTRL</sub> < 12VDC  
**DC-DC OFF:** Short or 0VDC < V<sub>CTRL</sub> < 1.2VDC

**Specifications** (measured @ Ta= 25°C, nom. Vin, full load and after warm-up unless otherwise stated)

**REMOTE SENSE**

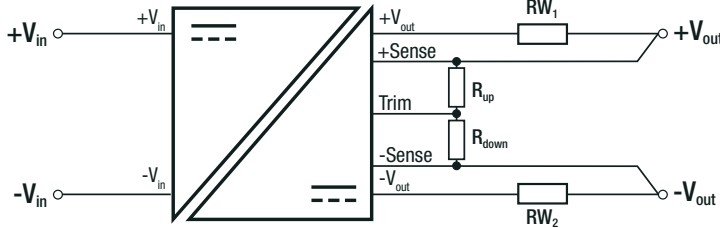

The output voltage can be adjusted by both trim and remote sense. The maximum combined adjustment range is  $\pm 10\%$ . Derate the maximum output power if using the trim or sense function to increase the output voltage.

- $R_{W1}$  = wire losses +
- $R_{W2}$  = wire losses -
- $R_{UP}$  = trim up resistor
- $R_{DOWN}$  = trim down resistor

**REGULATIONS**

Parameter	Condition	Value
Output Accuracy		$\pm 1.0\%$ typ. / $\pm 1.5\%$ max.
Line Regulation	low line to high line, full load	$\pm 0.2\%$ max.
Load Regulation	0% to 100% load	0.5% max.
Transient Response Recovery Time	25% load step change (75% - 100%)	500 $\mu$ s

**PROTECTIONS**

Parameter	Type		Value
Short Circuit Protection (SCP)			continuous, auto recovery
Over Voltage Protection (OVP)	shut down	nom. $V_{OUT} = 12VDC$	13.4 - 18VDC
		nom. $V_{OUT} = 24VDC$	26.9 - 36VDC
		nom. $V_{OUT} = 28VDC$	31.4 - 42VDC
		nom. $V_{OUT} = 48VDC$	53.8 - 72VDC
		nom. $V_{OUT} = 54VDC$	60.5 - 81VDC
Over Load Protection (OLP)			150% of rated $I_{OUT}$ , hiccup
Over Temperature Protection (OTP)	automatic restart after cooldown		115°C max.
Isolation Voltage <sup>(3)</sup>	1 minute	I/P to O/P	2.5kVDC
Isolation Resistance	$V_{ISO} = 500VDC$		1G $\Omega$ min.
Isolation Capacitance			3500pF max.

**Notes:**

Note3: For repeat Hi-Pot testing, reduce the time and/or the test voltage

**ENVIRONMENTAL**

Parameter	Condition		Value
Operating Temperature Range <sup>(4)</sup>	with derating (refer to below calculations)		-40°C to +105°C
Max. Baseplate Temperature			+105°C
Temperature Coefficient			0.05%/K max.
Thermal Impedance			refer to <b>"Thermal Calculation Example"</b>
Operating Altitude			5000m
Operating Humidity	non-condensing		5% - 95% RH max.
Pollution Degree			PD2
Vibration			according to MIL-STD-883G-Method-2026-Letter-D
MTBF	according to MIL-HDBK-217F, G.B.	+25°C	300 x 10 <sup>3</sup> hours

**Notes:**

Note4: Following calculations are made with REC150H-4812SUW. Test PCB: Eurocard 160x100mm 105 $\mu$ m copper, double layer

continued on next page

**Specifications** (measured @ Ta= 25°C, nom. Vin, full load and after warm-up unless otherwise stated)

### Thermal Derating with Fan Cooling and Double Layer PCB without Heatsink

Thermal Impedance	
airflow [m/s]	Rth [K/W]
0	5.5
0.25	5.0
0.5	4.4
1.0	4.0
1.5	2.8
2.0	2.5
2.5	2.2
3.0	1.9
3.5	1.6
4.0	1.3
4.5	1.2
5.0	1.1

#### Thermal Calculation Example

$$\begin{aligned}
 I_{out} &= 100\% \\
 R_{th} &= 2.2\text{K/W} \\
 P_{DISS} &= 21.395\text{W} \\
 T_{BASEmax} &= 105^\circ\text{C}
 \end{aligned}$$

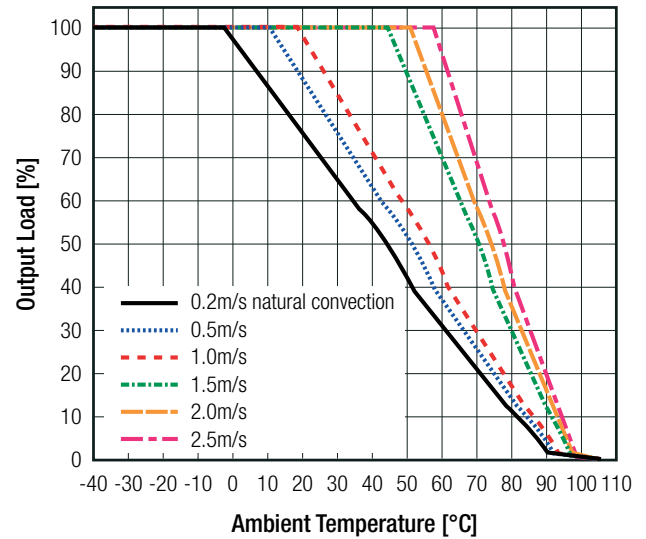

$$T_{OVER} = R_{th} \times P_{DISS} = 2.2\text{K/W} \times 21.395\text{W} = +47^\circ\text{C}$$

$$T_{AMBmax} = T_{BASEmax} - T_{OVER} = 105^\circ\text{C} - 47^\circ\text{C} = +58^\circ\text{C}$$

### Thermal Derating with Fan Cooling, Double Layer PCB and Heat-sink

Thermal Impedance	
airflow [m/s]	Rth [K/W]
0.2	3.83
0.5	3.58
0.7	3.16
1.0	2.85
1.2	2.67
1.5	2.28
2.0	1.96
2.5	1.70
3.0	1.44
3.5	1.18
4.0	0.92
4.5	0.75
5.0	0.65

#### Thermal Calculation Example

$$\begin{aligned}
 I_{out} &= 100\% \\
 R_{th} &= 2.67\text{K/W} \\
 P_{DISS} &= 21.395\text{W} \\
 T_{BASEmax} &= 105^\circ\text{C}
 \end{aligned}$$

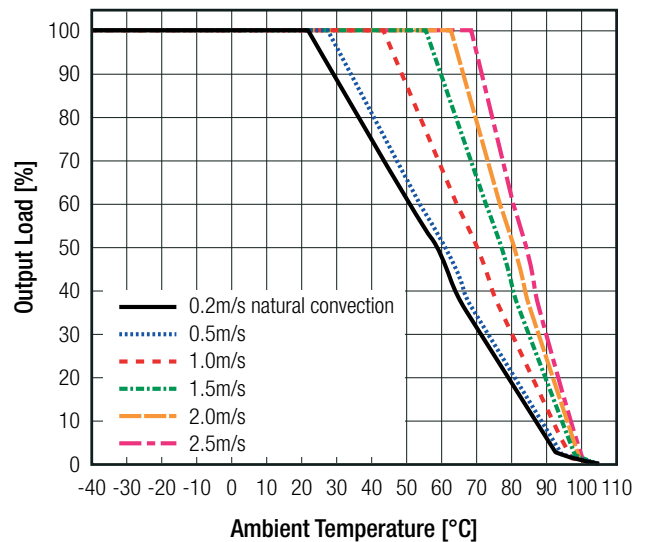

$$T_{OVER} = R_{th} \times P_{DISS} = 2.67\text{K/W} \times 21.395\text{W} = +57^\circ\text{C}$$

$$T_{AMBmax} = T_{BASEmax} - T_{OVER} = 105^\circ\text{C} - 57^\circ\text{C} = +48^\circ\text{C}$$

**Specifications** (measured @ Ta= 25°C, nom. Vin, full load and after warm-up unless otherwise stated)

### SAFETY AND CERTIFICATIONS

Certificate Type (Safety)	Report / File Number	Standard
Audio/Video, information and communication technology equipment - Part1: Safety requirements (CB)	pending	IEC62368-1:2018 3rd Edition
Audio/Video, information and communication technology equipment - Part1: Safety requirements		EN IEC 62368-1:2020+A11:2020
Audio/Video, information and communication technology equipment - Part1: Safety requirements (CB)	pending	UL62368-1:2019 3rd Edition
Audio/Video, information and communication technology equipment - Part1: Safety requirements		CAN/CSA-C22.2 No. 62368-1-19 3rd Edition
RoHS		RoHS-2011/65/EU + AM-2015/863
EMC Compliance	Condition	Standard / Criterion
Electromagnetic compatibility of multimedia equipment – Emission Requirements	with external components	EN55032:2015+A11:2020, Class A, B

### DIMENSION AND PHYSICAL CHARACTERISTICS

Parameter	Type	Value
Material	case	non-conductive black plastic, (UL94 V-0)
	baseplate	aluminum
	potting	silicone, (UL94 V-2)
	PCB	FR4, (UL94 V-1)
Dimension (LxWxH)		57.9 x 61.0 x 12.7mm
Weight		109g typ.

#### Dimension Drawing (mm)

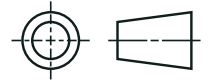
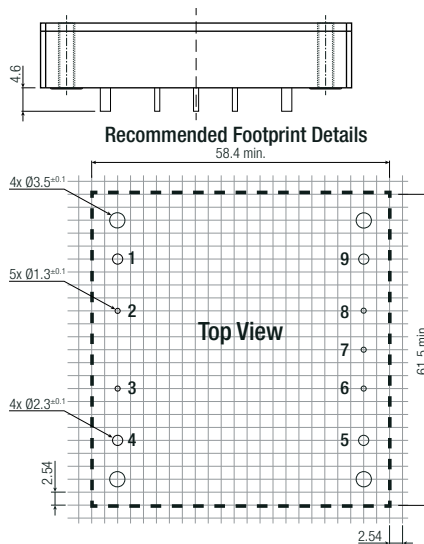
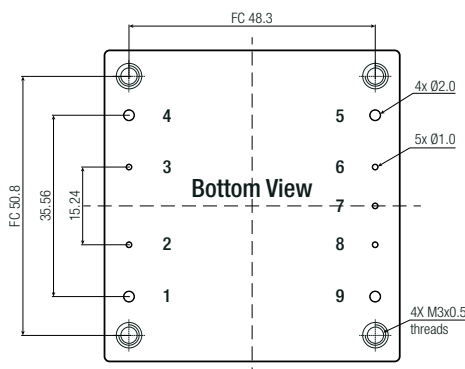
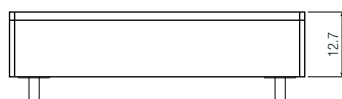
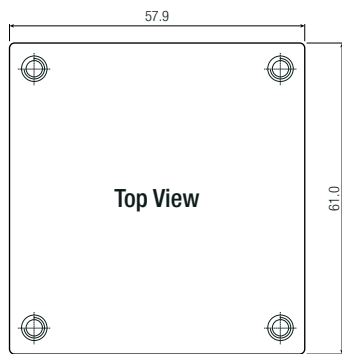

#### Pinning Information

Pin #	Function
1	+Vin
2	CTRL
3	Case
4	-Vin
5	-Vout
6	-Sense
7	Trim
8	+Sense
9	+Vout

FC= Fixing Centers for Heat-sink  
 XX.X = ±0.5mm  
 XX.XX = ±0.25mm  
 Pin Dimension Tolerance ±0.1mm

**Specifications** (measured @ Ta= 25°C, nom. Vin, full load and after warm-up unless otherwise stated)

PACKAGING INFORMATION		
Parameter	Type	Value
Packaging Dimension (LxWxH)	tube	520.0 x 60.9 x 26.9mm
Packaging Quantity		7pcs
Storage Temperature Range		-55°C to +125°C
Storage Humidity	non-condensing	95% RH max.

The product information and specifications may be subject to changes even without prior written notice. The product has been designed for various applications; its suitability lies in the responsibility of each customer. The products are not authorized for use in safety-critical applications without RECOM's explicit written consent. A safety-critical application is an application where a failure may reasonably be expected to endanger or cause loss of life, inflict bodily harm or damage property. The applicant shall indemnify and hold harmless RECOM, its affiliated companies and its representatives against any damage claims in connection with the unauthorized use of RECOM products in such safety-critical applications.