

THIS DRAWING IS UNPUBLISHED. RELEASED FOR PUBLICATION
 BY AMP INCORPORATED. ALL RIGHTS RESERVED.

LOC	DIST	REVISIONS					
		P	LTR	DESCRIPTION	DATE	DWN	APVD
G	86			REVISED PER 0L20-0217-97	24NOV97	DKS	MJS

1 2.41 [.095] MAX ALUMINUM FOIL THK

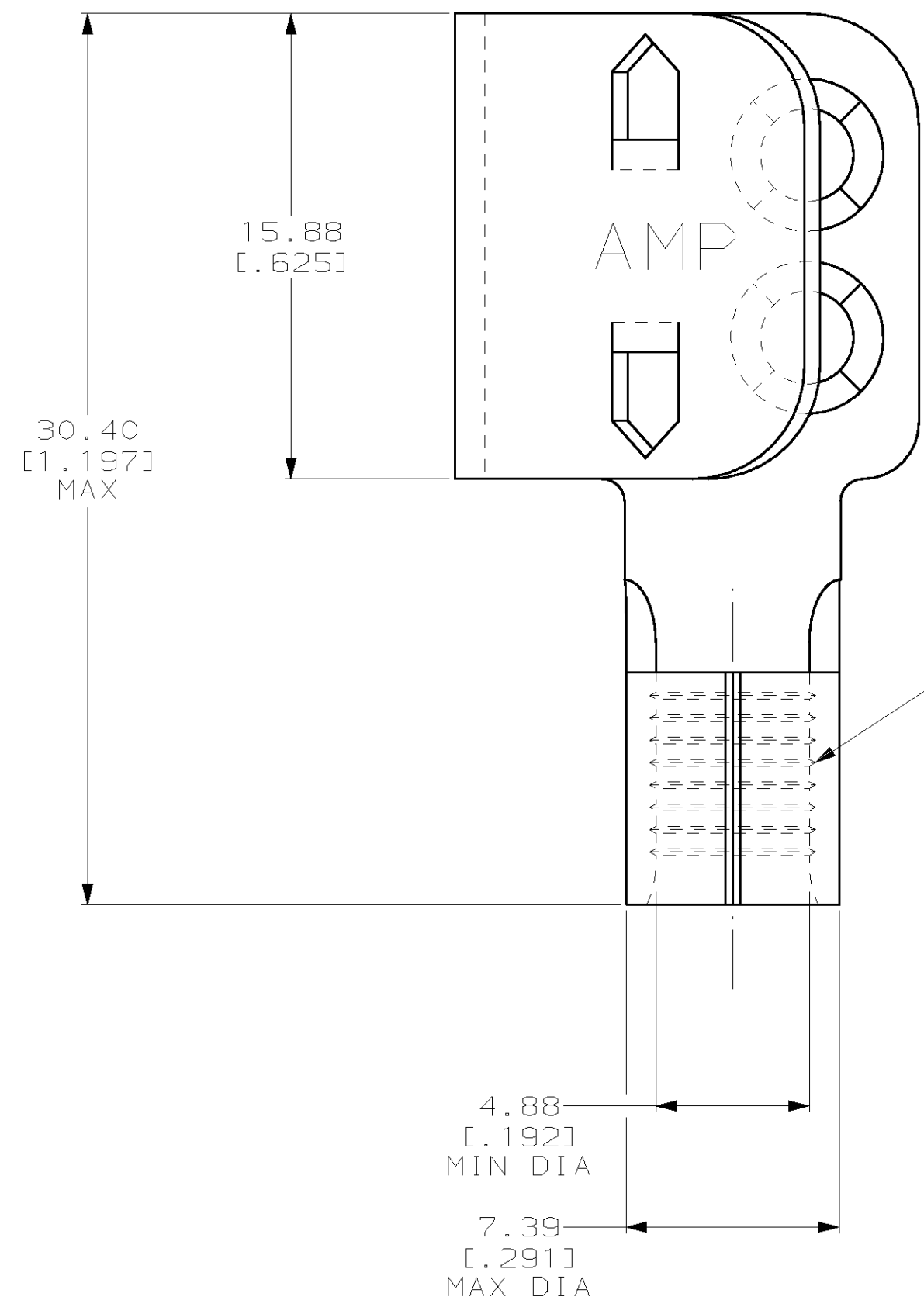

SERRATIONS

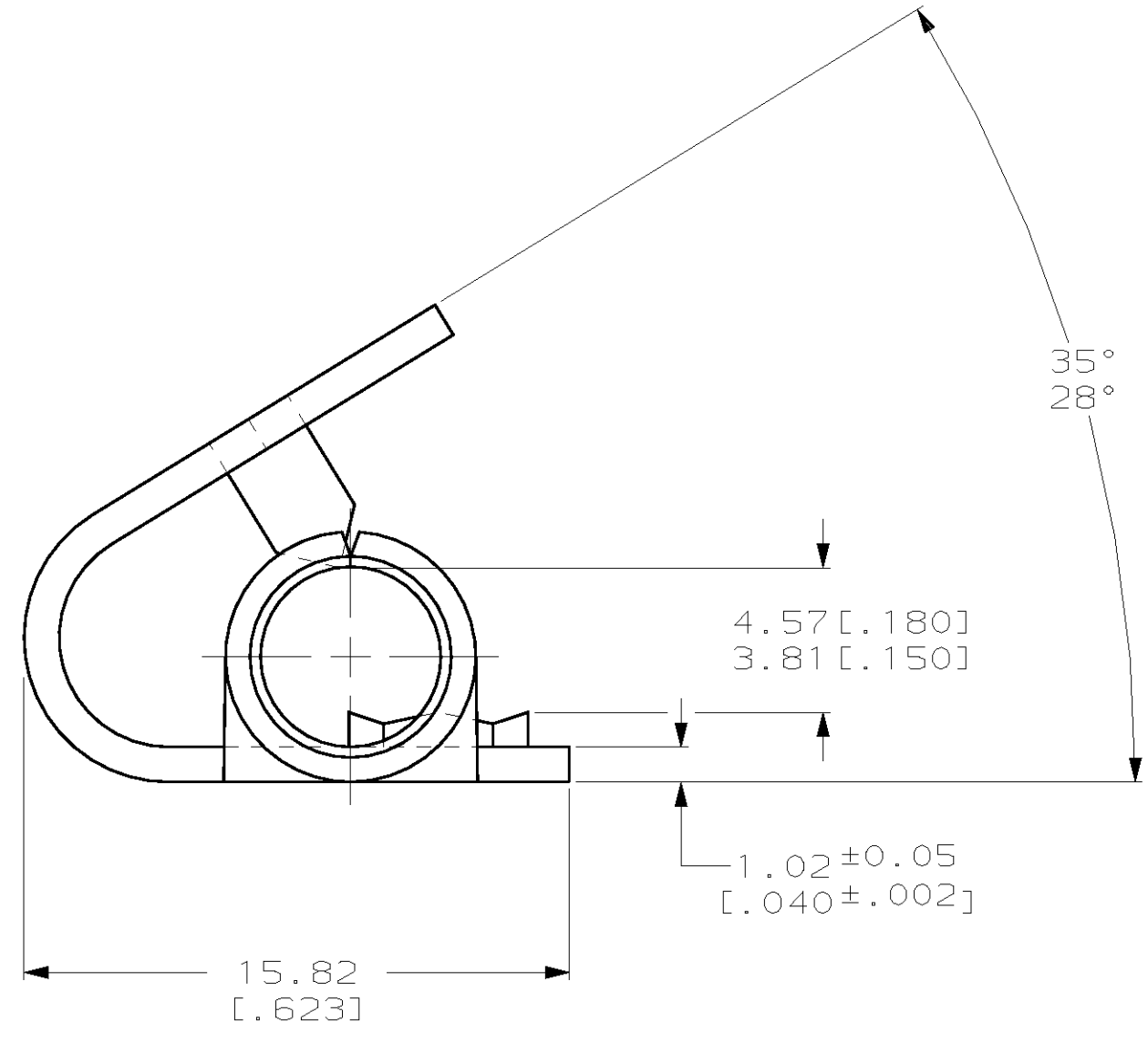

BRASS PER QQ-C-50	53660-4
STEEL PER QQ-S-698	53660-2
MATERIAL	AMP PART NUMBER

**AMP INCORPORATED
CUSTOMER SERVICE SYSTEMS**

FOR ADDITIONAL PRODUCT INFORMATION OR COPIES OF DRAWINGS AND TECHNICAL DOCUMENTS	PRODUCT INFORMATION CENTER 1-800-522-6752	RECOMMENDED OPERATING TEMPERATURE: 150°C MAX
FOR APPLICATION TOOLING INFORMATION	TOOLING ASSISTANCE CENTER 1-800-722-1111	VOLTAGE RATING: NOT APPLICABLE
FOR ORDER ENTRY	1-800-526-5142	WIRE CROSS SECTIONAL AREA RANGE: 6.64-10.50mm ² [13,100-20,800] CIR MILS SOLID OR STRANDED

THIS DRAWING IS A CONTROLLED DOCUMENT.

DIMENSIONS: mm [INCHES]	TOLERANCES UNLESS OTHERWISE SPECIFIED:
	0 PLC ±
	1 PLC ±
	2 PLC ±0.20 [.008]
	3 PLC ±
MATERIAL SEE TABLE	FINISH TIN PLATE 0.00254 [.000100] MIN THK PER ASTM B-545

DWN DK SCHRUM 25NOV97	CHK MJ SPICER 03DEC97	APVD JL MECKLEY 03DEC97	NAME W/ BARREL, TAP SPLICE, TERMI-FOIL™ WIRE SIZE: 8 AWG
PRODUCT SPEC -	APPLICATION SPEC -	WEIGHT -	SIZE A2
CUSTOMER DRAWING			SCALE 5:1
SHEET 1 OF 1			REV G

53660