

TOP VIEW

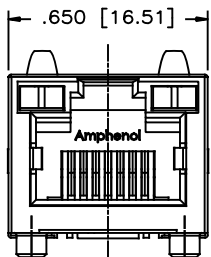

FRONT VIEW

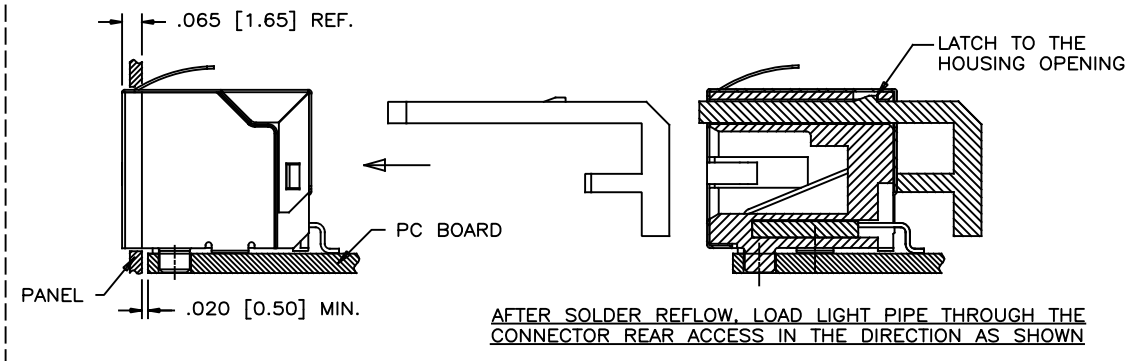

REVISIONS			
REV	DESCRIPTION, ECN, EAR NO.	DATE	APP'D
A	PROPOSAL	APR11/20	L.CHAN

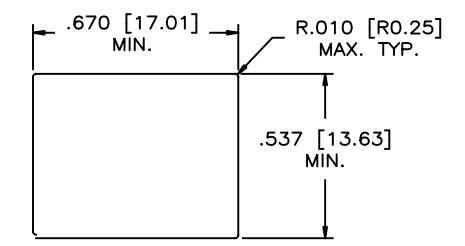

RECOMMENDED PANEL CUTOUT

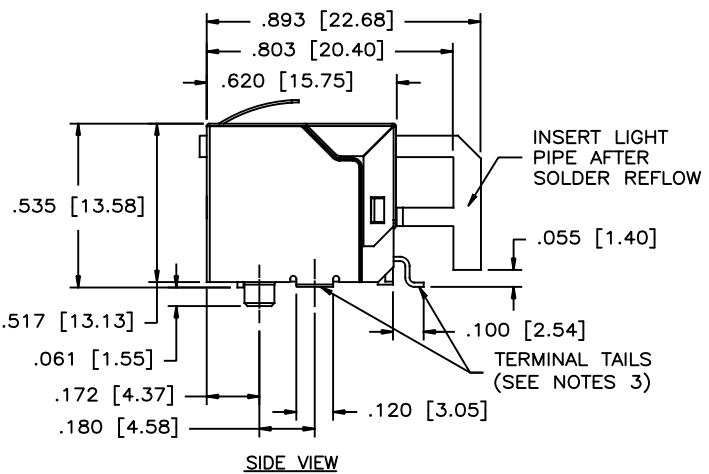

SIDE VIEW

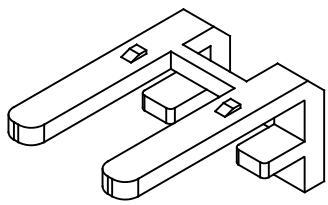

LIGHT PIPE

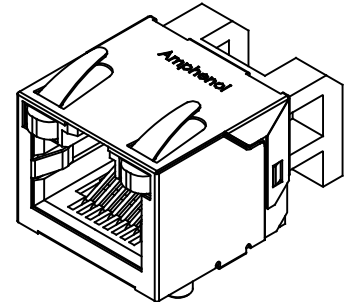

FINISH CONNECTOR

NOTES:

1. MATERIALS:  
HOUSING: HIGH TEMPERATURE ENGINEERING THERMOPLASTIC  
FLAMMABILITY RATING UL 94V-0, COLOR: BLACK

CONTACTS: PHOSPHOR BRONZE  
PLATING: 20 μ" [1.27 MICRONS] MIN.  
GOLD ON MATING SURFACES.  
50 μ" [1.27 MICRONS] MIN.  
NICKEL UNDERPLATE.  
100 μ" [2.54 MICRONS] MIN.  
MATTE TIN ON CONTACT TAILS.

SHIELD: COPPER ALLOY  
PLATING: NICKEL

LIGHT PIPE: CLEAR POLYCARBONATE  
FLAMMABILITY RATING UL 94V-0

2. COPLANARITY SPECIFICATION:  
THE MAXIMUM GAP BETWEEN ALL TERMINAL TAILS IS .004 [0.10]

3. RECOMMENDED SOLDERING TEMPERATURE:  
REFLOW SOLDERING AT 260°C MAXIMUM FOR 10 SECONDS  
MAXIMUM FOR ONE CYCLE.

AMPHENOL PART NUMBER: RJ SSE-5581-01T

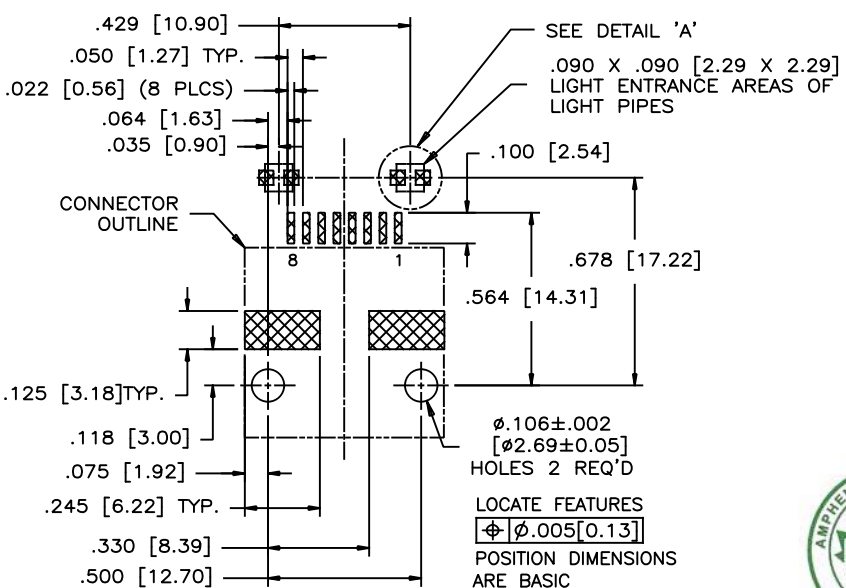

RECOMMENDED P.C.B. LAYOUT (COMPONENT SIDE OF BOARD)

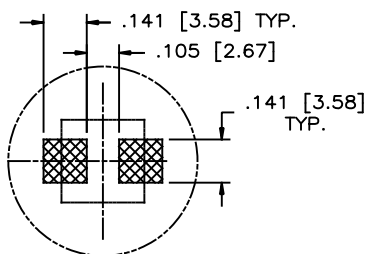

DETAIL 'A' (ENLARGED)  
SMT LED SOLDER PAD  
(SMT LED TO BE PROVIDED BY THE CUSTOMER)



UNLESS SPECIFIED OTHERWISE	DRAWN	RONNIE.C	APR11/20
PRIMARY UNITS INCHES	CHECKED	KELVIN.T	APR11/20
SECONDARY MILLIMETERS	M.E. APP'D		
REFERENCE IN PARENTHESES	Q.A. APP'D		
GENERAL TOLERANCES	DWG APP'D		
1 DECIMAL PLACE ±.025	ENG. REL. NO.		
2 DECIMAL PLACES ±.020	REF.		
3 DECIMAL PLACES ±.015			
ANGULAR DEGREES ±1.5°			

Amphenol Canada Corp. Commercial Products	
SINGLE PORT, SURFACE MOUNT, RJ45 MODULAR JACK, 8 POSITION, 8 CONTACTS, SHIELDED, TAPE & REEL PACKAGE, WITH LIGHT PIPES-RoHS COMPLIANT	
DWG NO. P-RJSSE-5581-01T	REV A
CODE ID NO. 03554	DWG SIZE X SCALE N/A SHEET 1 OF 2

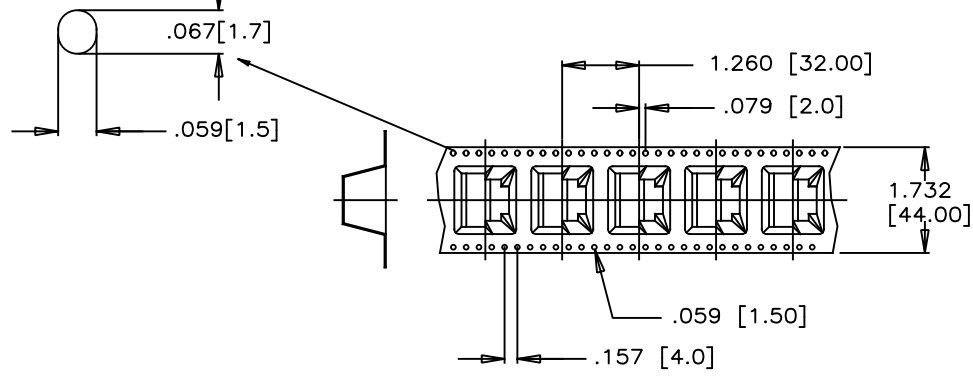

REVISIONS			
REV	DESCRIPTION, ECN, EAR NO.	DATE	APP'D
A	PROPOSAL	APR11/20	L.CHAN

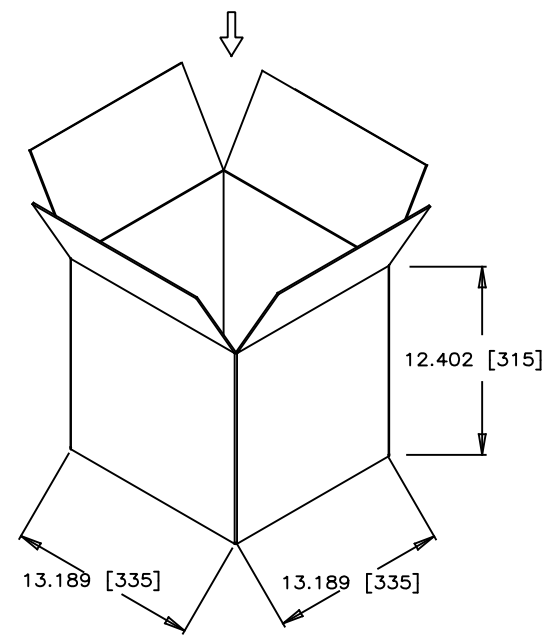
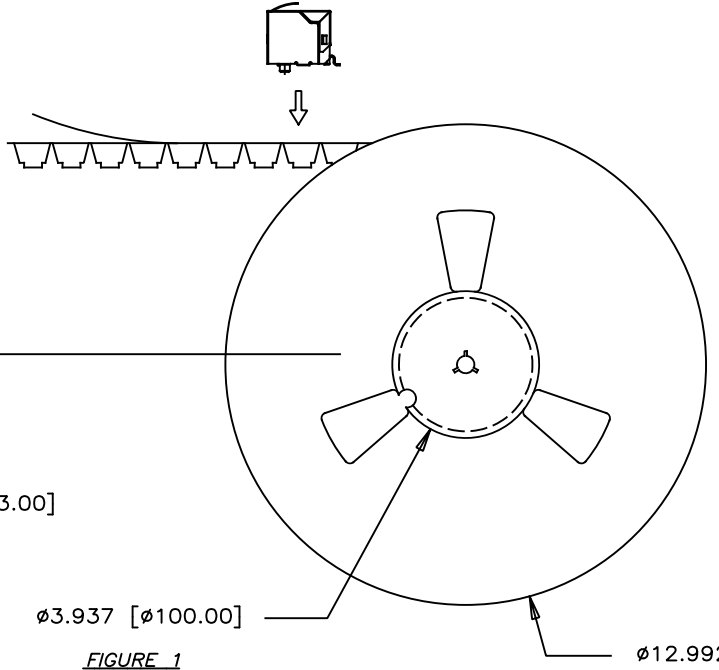
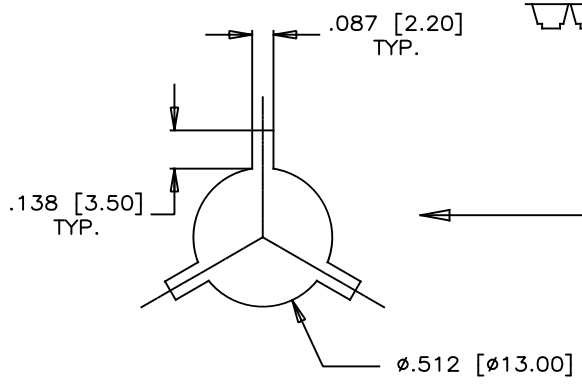
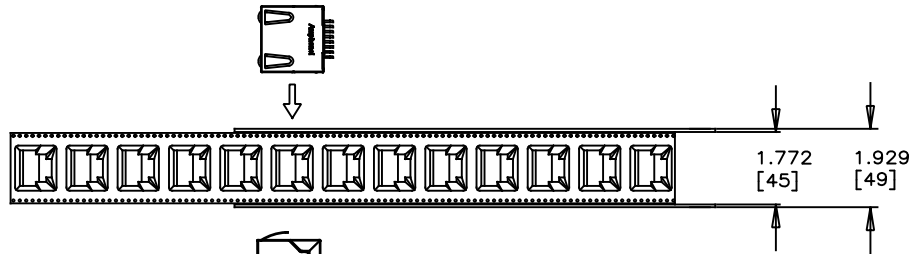
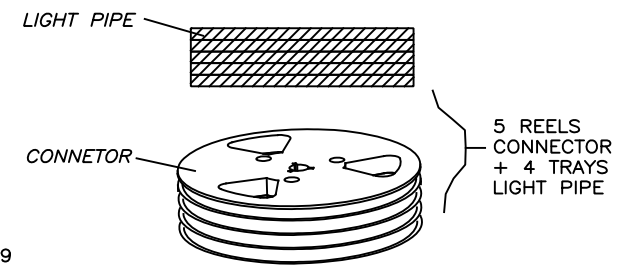

**FIGURE 1**  
**REEL WITH CARRIER TAPE & COVER**  
**REEL NOT EXACTLY AS SHOWN**

**FIGURE 2**  
**CARTON PACKAGING REFERENCE**  
**(DIMS SHOWN INSIDE OF BOX)**

- PACKAGING NOTES:**
- ONE REEL SHOULD HOLD 100 CONNECTORS.
  - 10 EMPTY CAVITIES FOR BOTH TOP AND BOTTOM OF THE CARRIER.
  - A FULLY LOADED CARTON SHOULD CONTAIN 5 REELS (500 PCS) OF CONNECTOR AND 4 TRAYS LIGHT PIPE.

UNLESS SPECIFIED OTHERWISE	DRAWN RONNIE.C	APR11/20
PRIMARY UNITS INCHES	CHECKED KELVIN.T	APR11/20
SECONDARY MILLIMETERS	M.E. APP'D	
REFERENCE IN PARENTHESES	Q.A. APP'D	
GENERAL TOLERANCES	DWG APP'D	
1 DECIMAL PLACE ±.025	ENG. REL. NO.	
2 DECIMAL PLACES ±.020	REF.	
3 DECIMAL PLACES ±.015		
ANGULAR DEGREES ±1.5°		

Amphenol Canada Corp. Commercial Products		
SINGLE PORT, SURFACE MOUNT, RJ45 MODULAR JACK, 8 POSITION, 8 CONTACTS, SHIELDED, TAPE & REEL PACKAGE, WITH LIGHT PIPES—RoHS COMPLIANT		
DWG NO.	P-RJSSE-5581-01T	REV A
CODE ID NO. 03554	DWG SIZE X	SCALE N/A SHEET 2 OF 2

THIS DOCUMENT CONTAINS PROPRIETARY INFORMATION AND SUCH INFORMATION MAY NOT BE DISCLOSED TO OTHERS FOR ANY PURPOSE OR USED FOR MANUFACTURING PURPOSES WITHOUT WRITTEN PERMISSION FROM AMPHENOL CANADA CORP.