

PART NUMBER	REVISION	DESCRIPTION	FEED TYPE
2151182-2	G	FINE CRIMP HEIGHT ADJUST	PNEUMATIC
5-2151182-2	G	SEAL STRIPPER CRIMPER TERMINATING UNIT	PNEUMATIC
7-2151182-2	G	PNEUMATIC AND CRIMP TOOLING KIT	PNEUMATIC
7-2151182-7	A	CRIMP TOOLING KIT	-

ATLANTIC VERSION TERMINATOR INTERFACE ADAPTER

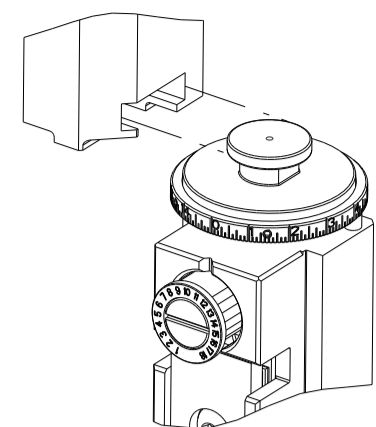

APPLICATOR DATA		
CRIMP	SIZE	TYPE
WIRE	2.29 mm [.090]	F
INSUL	3.30 mm [.130]	F

APPLICATOR INSTRUCTIONS
408-35042

TERMINAL DATA: TE TERMINAL		TE CRIMP SPECIFICATION	
TERMINAL NAME: POSITIVE LOCK RECEPTACLE			
WIRE STRIP LENGTH		INSULATION DIAMETER RANGE	
5.46-6.22 mm [.215-.245 IN]		Ø2.30-3.30 mm [.091-.130 IN]	
TERMINAL APPLICATION SPECIFICATION	114-2153		
TERMINALS APPLIED			
TE TERMINAL	TE TERMINAL	TE TERMINAL	TE TERMINAL
160759-1	160759-4	1-160759-9	3-160759-1
160759-2	1-160759-1	2-160759-9	3-160759-4
160759-3	1-160759-2	3-160759-0	2-160759-1

WIRE SIZE	CRIMP HEIGHT mm [INCH]	CRIMP HEIGHT REFERENCE SETTING
1.50mm2	1.65 +/- 0.05 [.065 +/- .002]	4.9
0.70mm2	1.60 +/- 0.05 [.063 +/- .002]	5.2
0.60mm2	1.50 +/- 0.05 [.059 +/- .002]	6.3
0.50mm2	1.45 +/- 0.05 [.057 +/- .002]	7.0

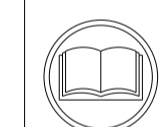

- 1 RECOMMENDED SPARE PARTS
- 2 REFER TO SUPPLIED INSTRUCTION SHEET FOR CLEANING, LUBRICATION AND STORAGE OF APPLICATOR.
- 3 APPLY PART NUMBER 2-23419-6 LOCTITE TO THREADS OF ITEM 242.
- 4 CRIMP HEIGHT REFERENCE SETTING WAS THE SETTING USED WHEN THE APPLICATOR WAS QUALIFIED AT THE FACTORY. ADJUSTMENT MAY BE NECESSARY WHEN RUNNING APPLICATOR IN THE FIELD.
- 5 TERMINAL PITCH NOT COMPATIBLE WITH MECHANICAL FEED.
- 6 TERMINAL LUBRICANT IS RECOMMENDED.
- 7. UNLESS SPECIFIED OTHERWISE TORQUE VALUES SHALL BE USED PER DOCUMENT, 101-35000.

***WARNING**
ON INSTALLATION, SET WIRE DISC TO CRIMP HEIGHT REFERENCE SETTING FOR LARGEST WIRE SIZE. CRIMP HEIGHT REFERENCE SETTINGS GREATER THAN THE VALUE SHOWN MAY CAUSE DAMAGE TO THE CRIMP TOOLING, REFER TO THE INSTRUCTION SHEET FOR PROPER SETUP AND ADJUSTMENTS.

LOC	DIST	REVISIONS					
		P	LTN	DESCRIPTION	DATE	OWN	APVD
A	66	E		ECR-18-012726	10AUG2018	MZ	CT
		F		ECR-19-005669	09APR2019	JAH	CT
		F1		ECR-19-014169	10SEP2019	FJ	TE
		G		ECR-21-124947	26JAN2022	MEH	TE

-	1	1	1	1-1803945-3	TONKER	300
-	1	1	1	4-22278-3	SPRING, COMPRESSION	299
-	2	2	2	4-18032-3	SCR, SET, FLT PNT, M3 X 6.0	298
-	1	1	1	1803944-1	SPACER, TONKER	297
-	-	1	-	2-1803583-1	APPLICATOR BASIC ASSEMBLY, SF	292
-	1	1	1	2119791-6	DEPRESSOR, WIRE	286
-	1	1	1	2119641-1	FEED CAM, AIR FEED	248
-	1	1	1	2119082-9	CAM, SNAIL, INSULATION ADJUSTMENT	244
-	1	1	1	2079764-1	WASHER, WAVE SPRING, CREST-TO-CREST	243
-	1	1	1	2119083-1	RETAINER, INSULATION DIAL	242
-	1	1	1	7-18023-7	SCR, SKT HD CAP M3 X 4.0	241
-	1	1	1	2844940-2	AIR FEED MODULE	238
-	REF	REF	REF	994970-2	COUNTER, MAGNETIC	164
-	1	1	1	2119955-1	ASSY, LUBRICATOR, SIDE FEED	113
-	1	1	1	2844908-1	SCREW, LOCKING	99
-	1	1	1	2844907-1	POST, LOCKING	98
-	1	1	1	455888-4	SPACER, CRIMPER	82
-	2	2	2	2168083-1	SCR, SKT HD CAP, RoHS, M3 X 8.0	73
-	1	1	1	693855-8	FRONT STRIP GUIDE	72
-	1	1	1	1803607-3	DOCUMENTATION PACKAGE	71
-	1	1	1	2119740-1	TAG, IDENTIFICATION	67
-	2	2	2	2168078-1	SCREW, DRIVE, RH, RoHS, 2 x .188	66
-	1	1	1	2168083-2	SCR, SKT HD CAP, RoHS, M4 X 8.0	60
-	1	1	1	5-18022-5	SCR, HEX HD CAP, M4 X 6.0	59
-	1	1	1	1338685-1	PAWL, FEED	56
-	4	4	4	2168083-3	SCR, SKT HD CAP, RoHS, M4 X 12.0	54
-	2	2	2	2168083-8	SCR, SKT HD CAP, RoHS, M4 X 16	53
-	1	1	1	18023-9	SCR, SKT HD CAP M4 X 6.0	49
-	1	-	1	1803583-9	APPLICATOR BASIC ASSEMBLY, SF	46
-	1	1	1	1803515-1	RAM ASSEMBLY, SF ATLANTIC	44
-	1	1	1	1803602-1	SCR, BHSC, RoHS (M8 X 25)	41
-	1	1	1	1-1752356-3	SUPPORT, TERMINAL	34
-	2	2	2	2079383-5	SCR, BHSC, RoHS (M4 X 20)	33
-	2	2	2	2-18032-5	SCR, SET, FLT PNT, M5 X 20.0	31
-	2	2	2	3-2844962-0	SPACER, CYLINDRICAL, STRIP GUIDE	30
-	1	1	1	2844992-3	ASSEMBLY, STRIP GUIDE	29
-	2	2	2	22283-1	SPRING, COMPRESSION	27
-	1	1	1	356835-1	LEVER, DRAG RELEASE	26
-	1	1	1	240792-1	DRAG, TERMINAL	25
-	1	1	1	1320928-2	STRIP GUIDE	24
-	1	1	1	980371-4	SCR, SKT HD SHLDR 5.0 DIA X 6.0	23
-	1	-	1	2168083-2	SCR, SKT HD CAP, RoHS, M4 X 8.0	21
-	2	-	2	1-18028-2	WASHER, FLAT, REG M4	20
-	1	-	1	2119533-1	STRIPPER, SIDE FEED	19
-	1	1	1	318563-1	GUARD, FRONT CHIP	14
-	1	1	1	2119806-1	INSERT, SHEAR	13
-	1	1	1	3-22280-3	SPRING, COMPRESSION	12
-	1	1	1	1-356885-4	STOP, SHEAR	11
-	1	1	1	2119805-1	SHEAR HOLDER, FRONT	10
-	1	1	1	1803095-6	FLOATING SHEAR, FRONT	9
-	1	2	1	1333205-2	ANVIL, COMBINATION	8
-	1	1	1	2-240641-4	SPACER	7
-	1	1	1	2119757-8	DEPRESSOR, SHEAR	5
-	1	1	1	1-238011-7	BLOCK, CRIMPER SPACER	4
-	1	2	1	1-1633961-5	CRIMPER, INSULATION F PREMIUM	3
-	1	1	1	455888-8	SPACER, CRIMPER	2
-	1	2	1	1-456406-1	CRIMPER, WIRE PREMIUM	1

DIMENSIONS:		TOLERANCES UNLESS OTHERWISE SPECIFIED:		DRAWING NO		RESTRICTED TO	
mm	0 PLC ±	1 PLC ±	2 PLC ±	3 PLC ±	4 PLC ±	ANGLES ±	FINISH ±
MATERIAL				WEIGHT	SCALE	SHEET	REV
APPLICATOR DATA				00779	1:2	1 OF 4	G

ATLANTIC VERSION
Shown on sheets 1 of 4 & 2 of 4
(Pacific version shown on sheets 3 of 4 & 4 of 4)

LOC	DIST	REVISIONS					
A	66	P	LTN	DESCRIPTION	DATE	DWN	APVD
		-		SEE SHEET 1			

FEED TYPE

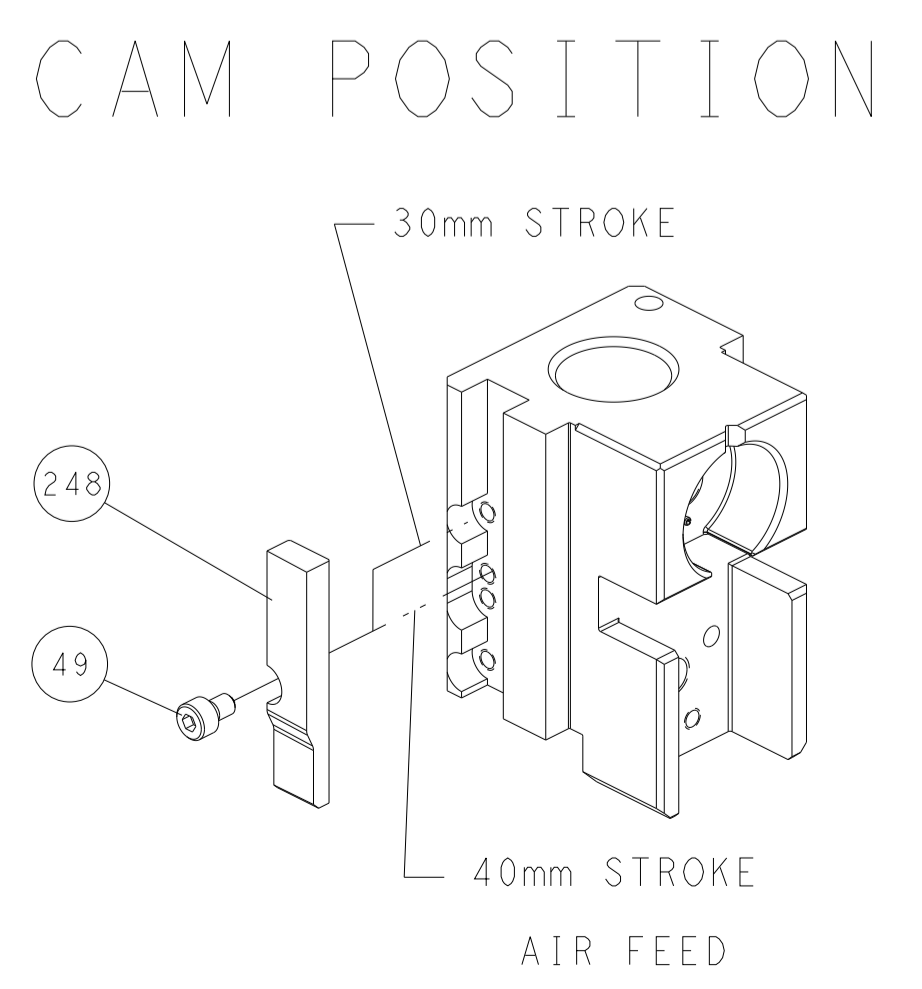
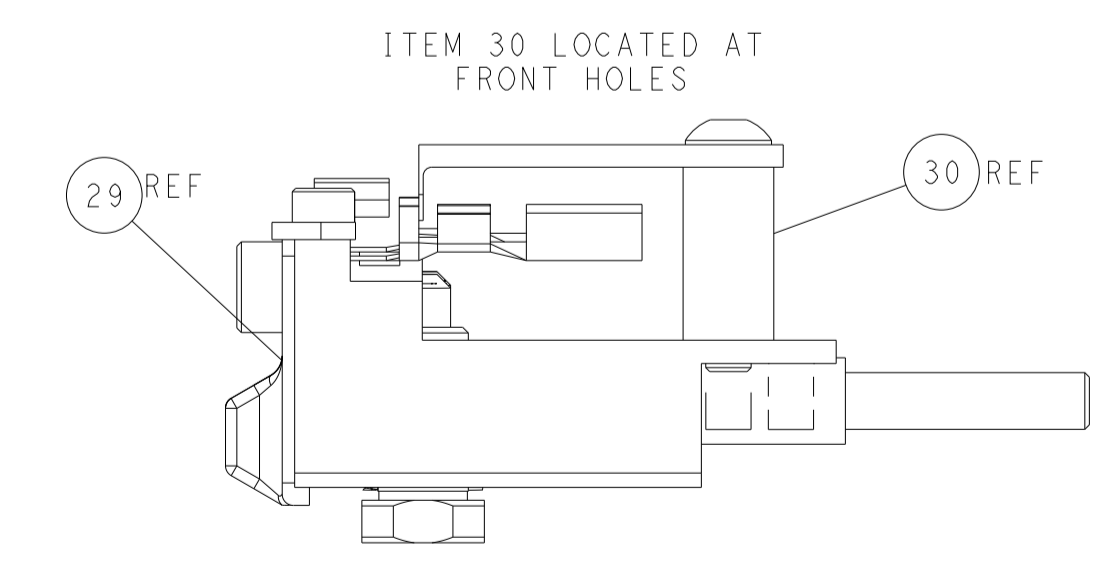
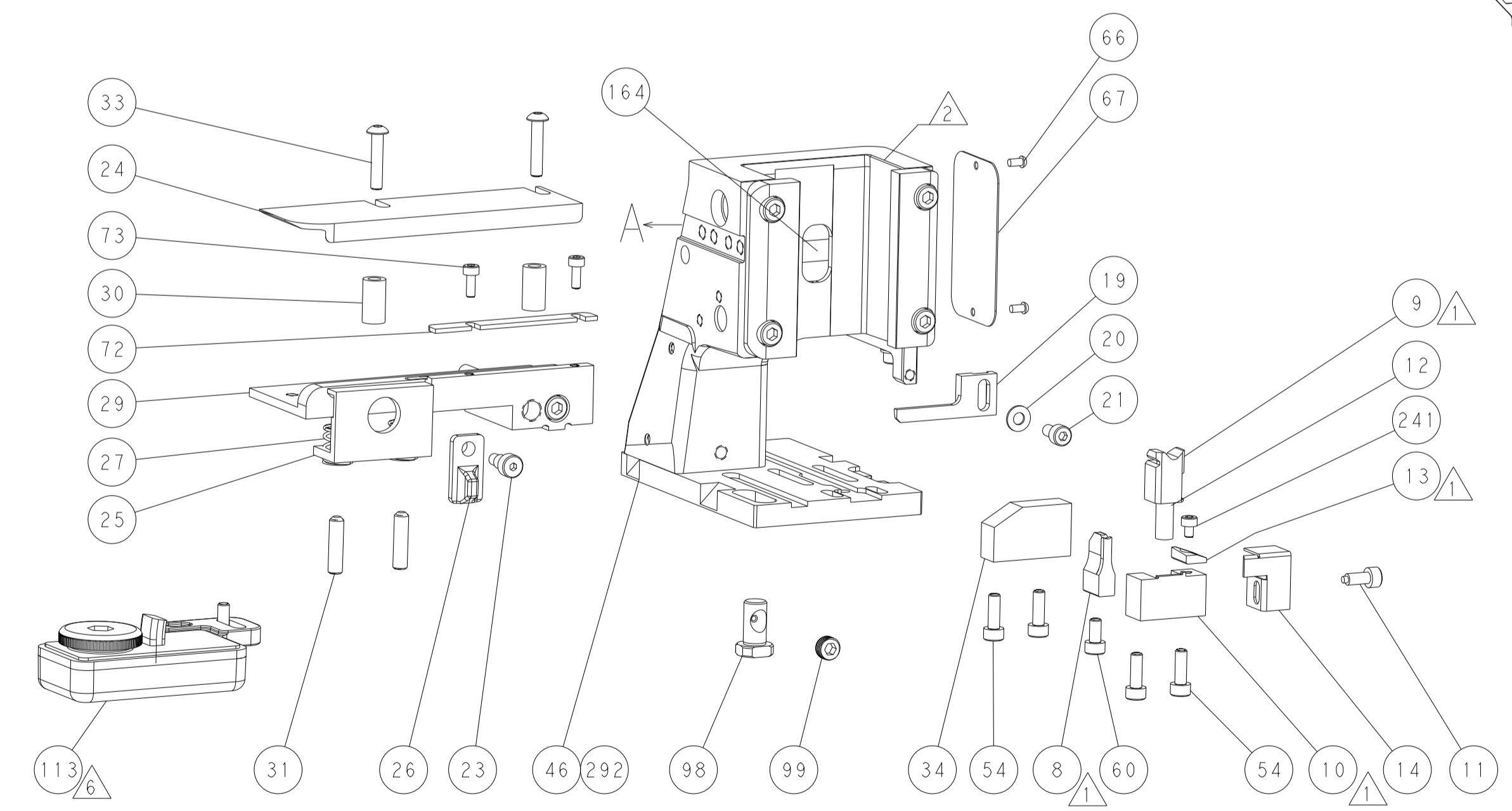
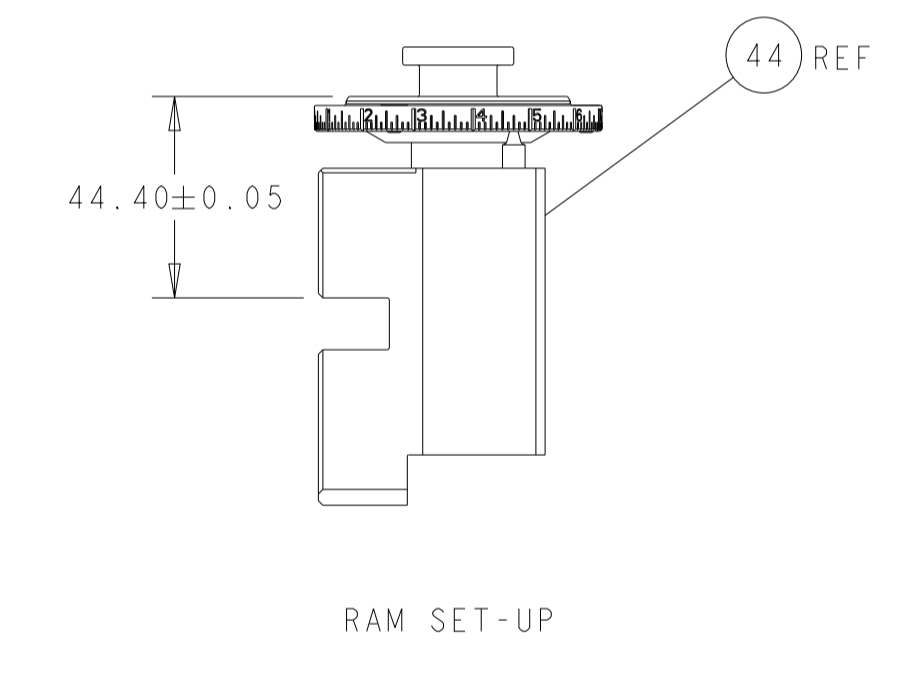
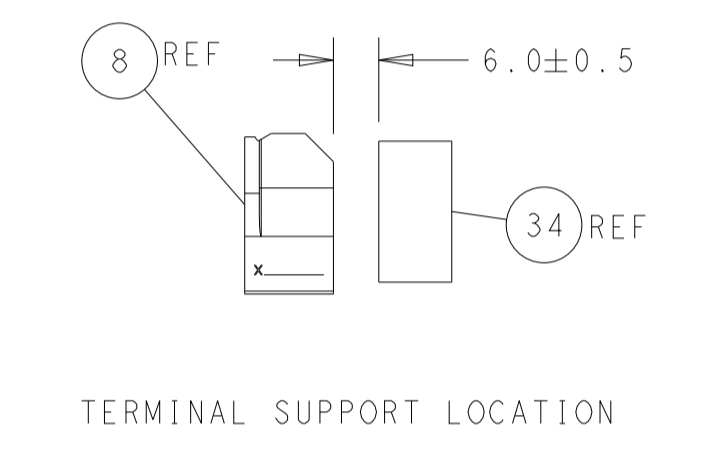
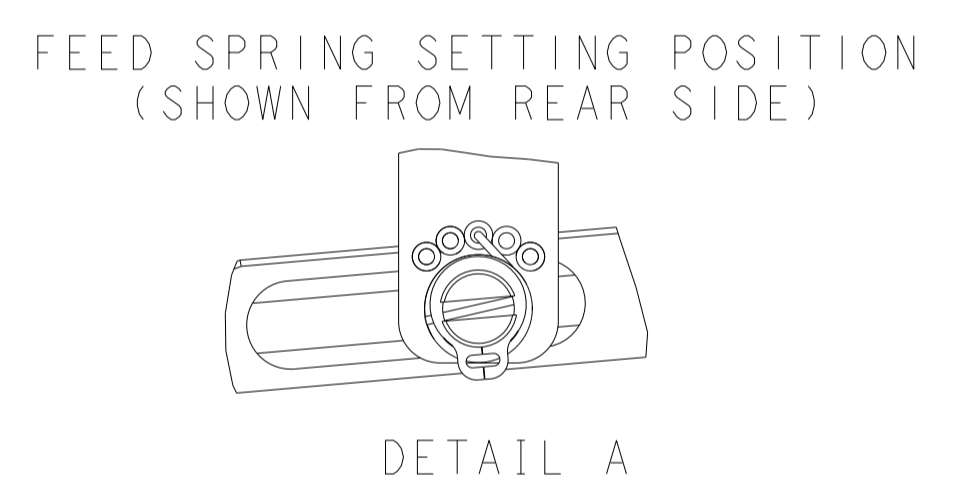
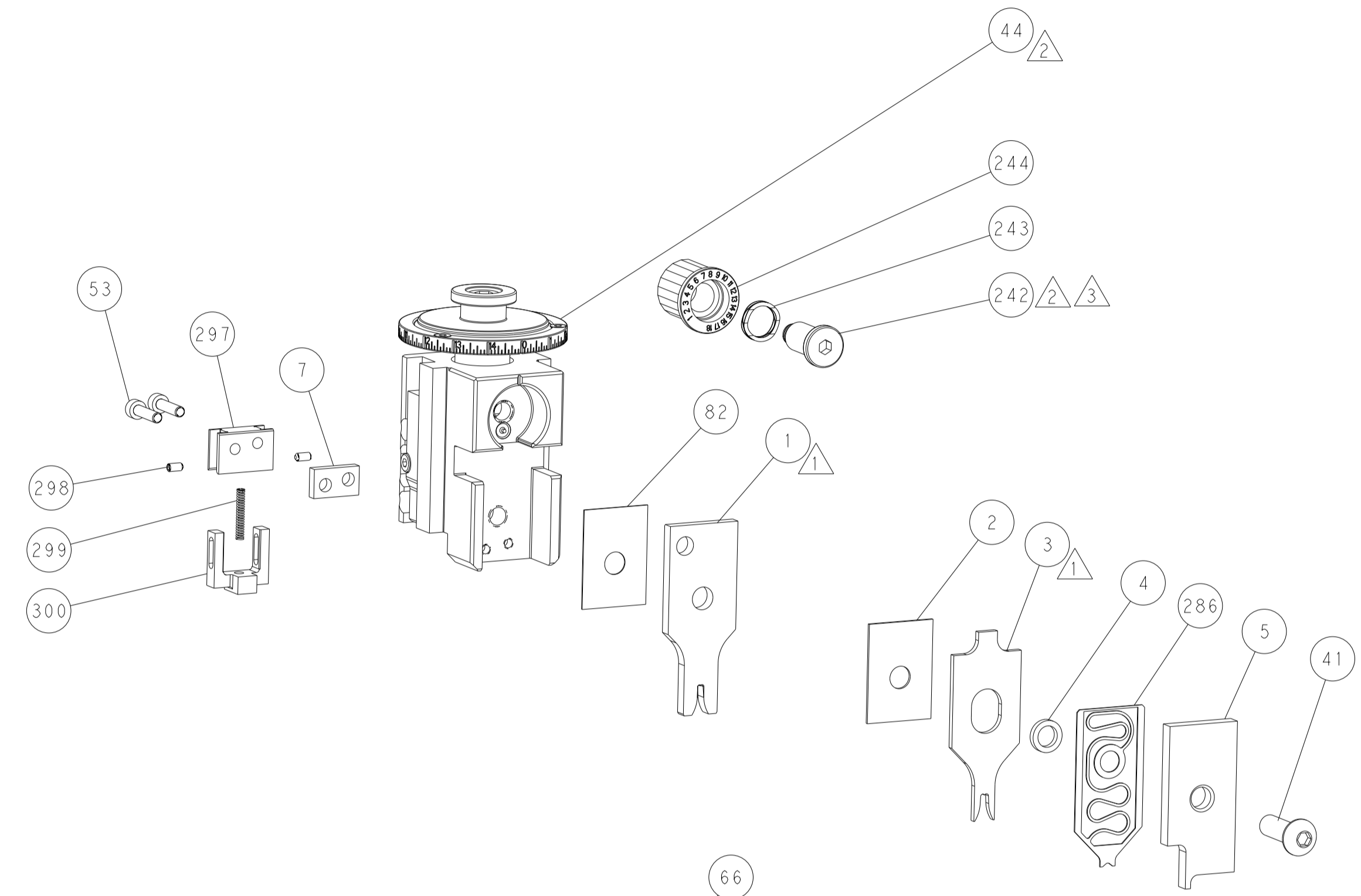
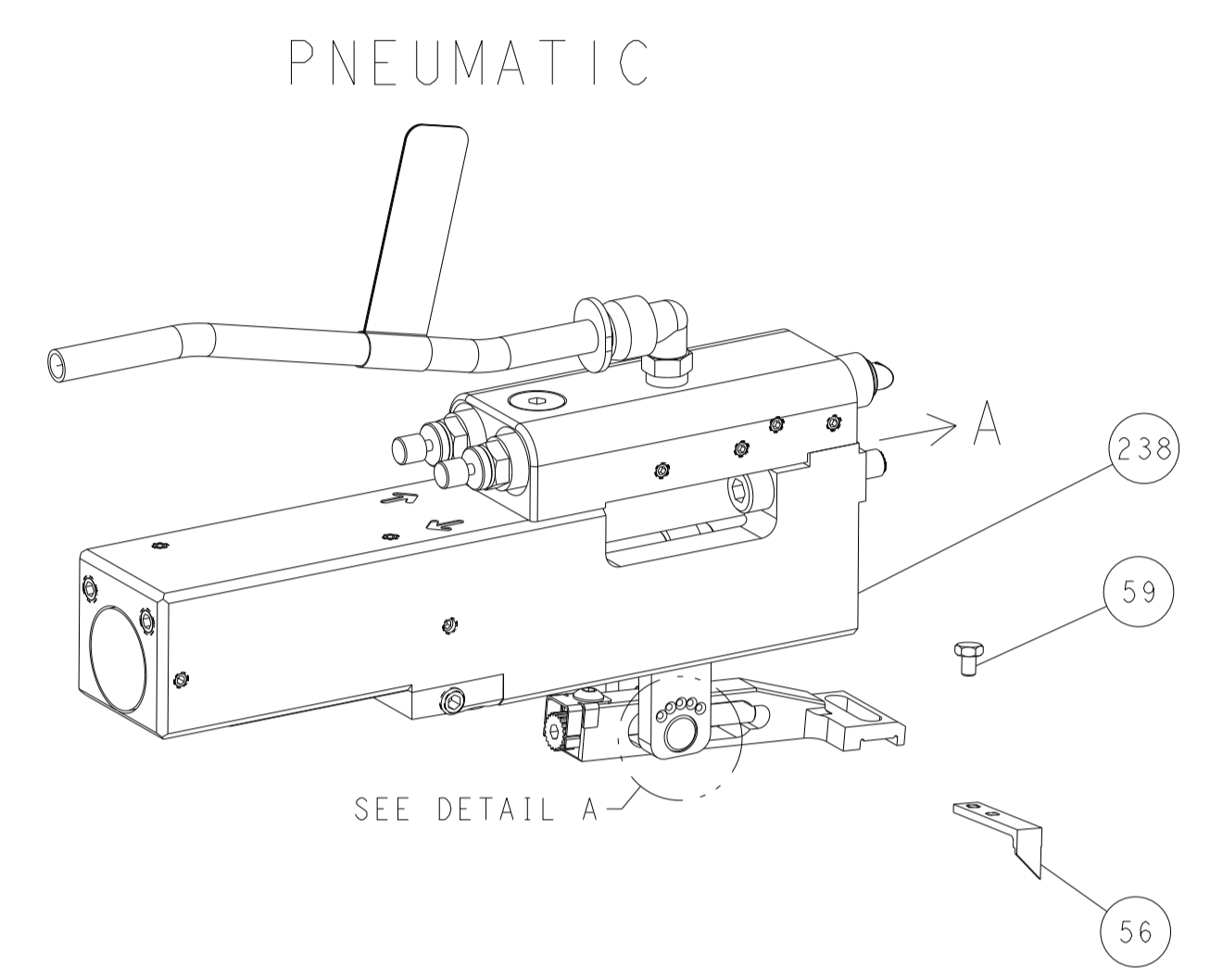

FEED TRACK POSITION
GUIDE BY INSULATION BARREL

ATLANTIC VERSION
 Shown on sheets 1 of 4 & 2 of 4
 (Pacific version shown on sheets 3 of 4 & 4 of 4)

DIMENSIONS:		TOLERANCES UNLESS OTHERWISE SPECIFIED:		DWN Y. YIN 17AUG2011		TE Connectivity	
mm	0 PLC ±	1 PLC ±	2 PLC ±	3 PLC ±	4 PLC ±	Harrisburg, PA 17105-3608	
	ANGLES	FINISH		CHK G. BAILEY 17AUG2011		NAME	
MATERIAL				S. XI 17AUG2011		Ocean Side Feed Applicator	
				APVD		SIZE CAGE CODE DRAWING NO RESTRICTED TO	
				PRODUCT SPEC		A1 00779 ©=2151182	
				APPLICATION SPEC		SCALE 1:2 SHEET 2 OF 4 REV G	
				WEIGHT		CUSTOMER ACCESSIBLE PRODUCTION DRAWING	

THIS DRAWING IS UNPUBLISHED.	RELEASED FOR PUBLICATION		
COPYRIGHT 20 BY TYCO ELECTRONICS CORPORATION. ALL RIGHTS RESERVED.			
PART NUMBER	REVISION	DESCRIPTION	FEED TYPE
2-2151182-2	G	FINE CRIMP HEIGHT ADJUST	PNEUMATIC
7-2151182-7	A	CRIMP TOOLING KIT	-

PACIFIC VERSION TERMINATOR
INTERFACE ADAPTER

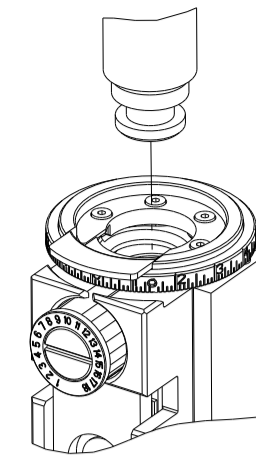

APPLICATOR DATA		
CRIMP	SIZE	TYPE
WIRE	2.29 mm [.090]	F
INSUL	3.30 mm [.130]	F
APPLICATOR INSTRUCTIONS 408-35042		

TERMINAL DATA: TE TERMINAL		TE CRIMP SPECIFICATION	
TERMINAL NAME: POSITIVE LOCK RECEPTACLE			
WIRE STRIP LENGTH 5.46-6.22 mm [1.215-.245 IN]		INSULATION DIAMETER RANGE Ø2.30-3.30 mm [.091-.130 IN]	
TERMINAL APPLICATION SPECIFICATION 114-2153			
TERMINALS APPLIED			
TE TERMINAL	TE TERMINAL	TE TERMINAL	TE TERMINAL
160759-1	160759-4	1-160759-9	3-160759-1
160759-2	1-160759-1	2-160759-9	3-160759-4
160759-3	1-160759-2	3-160759-0	2-160759-1

WIRE SIZE	CRIMP HEIGHT mm [INCH]	CRIMP HEIGHT REFERENCE SETTING
1.50mm2	1.65+/-0.05 [1.065+/-0.002]	4.9
0.70mm2	1.60+/-0.05 [1.063+/-0.002]	5.2
0.60mm2	1.50+/-0.05 [1.059+/-0.002]	6.3
0.50mm2	1.45+/-0.05 [1.057+/-0.002]	7.0



- △ RECOMMENDED SPARE PARTS
- △ REFER TO SUPPLIED INSTRUCTION SHEET FOR CLEANING, LUBRICATION AND STORAGE OF APPLICATOR.
- △ APPLY PART NUMBER 2-23419-6 LOCTITE TO THREADS OF ITEM 242.
- △ CRIMP HEIGHT REFERENCE SETTING WAS THE SETTING USED WHEN THE APPLICATOR WAS QUALIFIED AT THE FACTORY. ADJUSTMENT MAY BE NECESSARY WHEN RUNNING APPLICATOR IN THE FIELD.
- △ TERMINAL PITCH NOT COMPATIBLE WITH MECHANICAL FEED.
- △ TERMINAL LUBRICANT IS RECOMMENDED.
- 7. UNLESS SPECIFIED OTHERWISE TORQUE VALUES SHALL BE USED PER DOCUMENT, 101-35000.

***WARNING**
ON INSTALLATION, SET WIRE DISC TO CRIMP HEIGHT REFERENCE SETTING FOR LARGEST WIRE SIZE. CRIMP HEIGHT REFERENCE SETTINGS GREATER THAN THE VALUE SHOWN MAY CAUSE DAMAGE TO THE CRIMP TOOLING, REFER TO THE INSTRUCTION SHEET FOR PROPER SETUP AND ADJUSTMENTS.

PACIFIC VERSION
Shown on sheets 3 of 4 & 4 of 4
(Atlantic version shown on sheets 1 of 4 & 2 of 4)

LOC	DIST	REVISIONS					
A	66	P	LTN	DESCRIPTION	DATE	DWN	APVD
		-		SEE SHEET 1			

-	1	1-1803945-3	TONKER	300
-	1	4-22278-3	SPRING, COMPRESSION	299
-	2	4-18032-3	SCR, SET, FLT PNT, M3 X 6.0	298
-	1	1803944-1	SPACER, TONKER	297
-	1	2119791-6	DEPRESSOR, WIRE	286
-	1	2119082-9	CAM, SNAIL, INSULATION ADJUSTMENT	244
-	1	2079764-1	WASHER, WAVE SPRING, CREST-TO-CREST	243
△	1	2119083-1	RETAINER, INSULATION DIAL	242
-	1	7-18023-7	SCR, SKT HD CAP M3 X 4.0	241
-	1	2844940-2	AIR FEED MODULE	238
-	REF	994970-2	COUNTER, MAGNETIC	164
-	1	2119641-2	FEED CAM, AIR FEED	151
-	1	2168083-8	SCR, SKT HD CAP, RoHS, M4 X 16	144
-	4	2168083-9	SCR, SKT HD CAP, RoHS, M4 X 20	143
-	1	1-1803583-0	APPLICATOR BASIC ASSEMBLY, SF	141
-	1	1803516-1	RAM ASSEMBLY, SF PACIFIC	140
△	1	2119955-1	ASSY, LUBRICATOR, SIDE FEED	113
-	1	2844908-1	SCREW, LOCKING	99
-	1	2844907-1	POST, LOCKING	98
-	1	455888-4	SPACER, CRIMPER	82
-	2	2168083-1	SCR, SKT HD CAP, RoHS, M3 X 8.0	73
-	1	693855-8	FRONT STRIP GUIDE	72
-	1	1803607-3	DOCUMENTATION PACKAGE	71
-	1	2119740-1	TAG IDENTIFICATION	67
-	2	2168078-1	SCREW, DRIVE, RH, RoHS, 2 x .188	66
-	1	5-18022-5	SCR, HEX HD CAP, M4 X 6.0	59
-	1	1338685-1	PAWL, FEED	56
-	2	2168083-8	SCR, SKT HD CAP, RoHS, M4 X 16	53
-	1	18023-9	SCR, SKT HD CAP M4 X 6.0	49
-	1	1803602-1	SCR, BHSC, RoHS (M8 X 25)	41
-	1	1-1752356-3	SUPPORT, TERMINAL	34
-	2	2079383-5	SCR, BHSC, RoHS (M4 X 20)	33
-	2	2-18032-5	SCR, SET, FLT PNT, M5 X 20.0	31
-	2	3-2844962-0	SPACER, CYLINDRICAL, STRIP GUIDE	30
-	1	2844992-3	ASSEMBLY, STRIP GUIDE	29
-	2	22283-1	SPRING, COMPRESSION	27
-	1	356835-1	LEVER, DRAG RELEASE	26
-	1	240792-1	DRAG, TERMINAL	25
-	1	1320928-2	STRIP GUIDE	24
-	1	980371-4	SCR, SKT HD SHLDR 5.0 DIA X 6.0	23
-	1	2168083-2	SCR, SKT HD CAP, RoHS, M4 X 8.0	21
-	1	1-18028-2	WASHER, FLAT, REG M4	20
-	1	2119533-1	STRIPPER, SIDE FEED	19
-	1	318563-1	GUARD, FRONT CHIP	14
△	1	2119806-1	INSERT, SHEAR	13
-	1	3-22280-3	SPRING, COMPRESSION	12
-	1	1-356885-4	STOP, SHEAR	11
-	1	2119805-1	SHEAR HOLDER, FRONT	10
△	1	1803095-6	FLOATING SHEAR, FRONT	9
△	1	1333205-2	ANVIL, COMBINATION	8
△	1	2-240641-4	SPACER	7
-	1	2119757-8	DEPRESSOR, SHEAR	5
-	1	1-238011-7	BLOCK, CRIMPER SPACER	4
△	1	1-1633961-5	CRIMPER, INSULATION F PREMIUM	3
-	1	455888-8	SPACER, CRIMPER	2
△	1	1-456406-1	CRIMPER, WIRE PREMIUM	1

DIMENSIONS:		TOLERANCES UNLESS OTHERWISE SPECIFIED:		DWN Y. YIN 17AUG2011		TE Connectivity Harrisburg, PA 17105-3608	
mm		0 PLC ±		CHK G. BAILEY 17AUG2011		NAME Ocean Side Feed Applicator	
		1 PLC ±		APVD S. XI 17AUG2011		SIZE CAGE CODE DRAWING NO RESTRICTED TO	
		2 PLC ±		PRODUCT SPEC		A1 00779 ©=2151182	
		3 PLC ±		APPLICATION SPEC		CUSTOMER ACCESSIBLE PRODUCTION DRAWING SCALE 1:2 SHEET 3 OF 4 REV G	
		4 PLC ±		WEIGHT			
		ANGLES FINISH					

LOC	DIST	REVISIONS			
P	LTN	DESCRIPTION	DATE	OWN	APVD
A	66	SEE SHEET 1			

FEED TYPE

PNEUMATIC

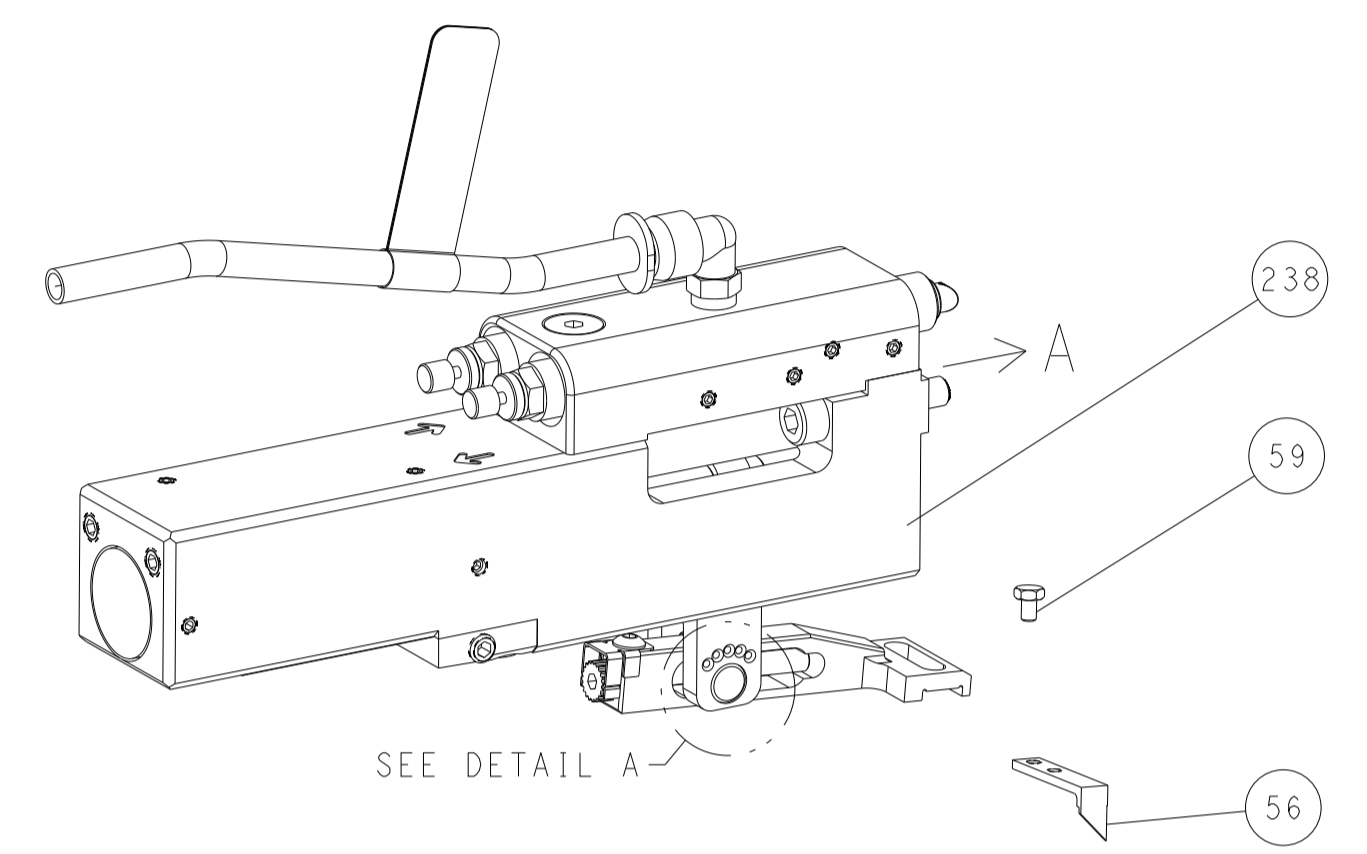

FEED SPRING SETTING POSITION (SHOWN FROM REAR SIDE)

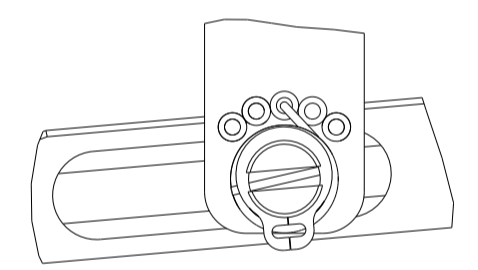

DETAIL A

CAM POSITION

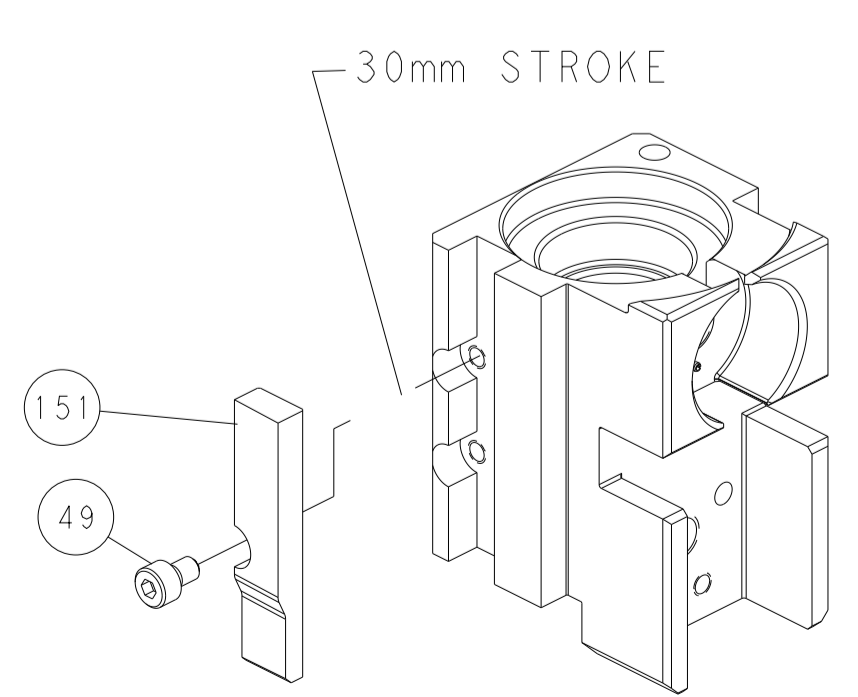

AIR FEED

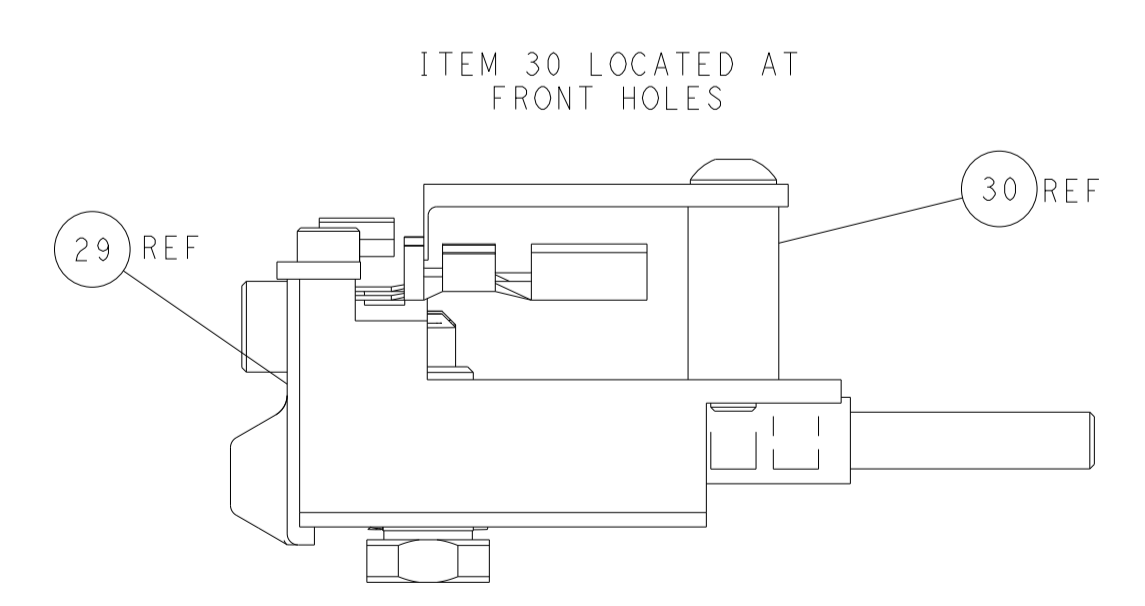
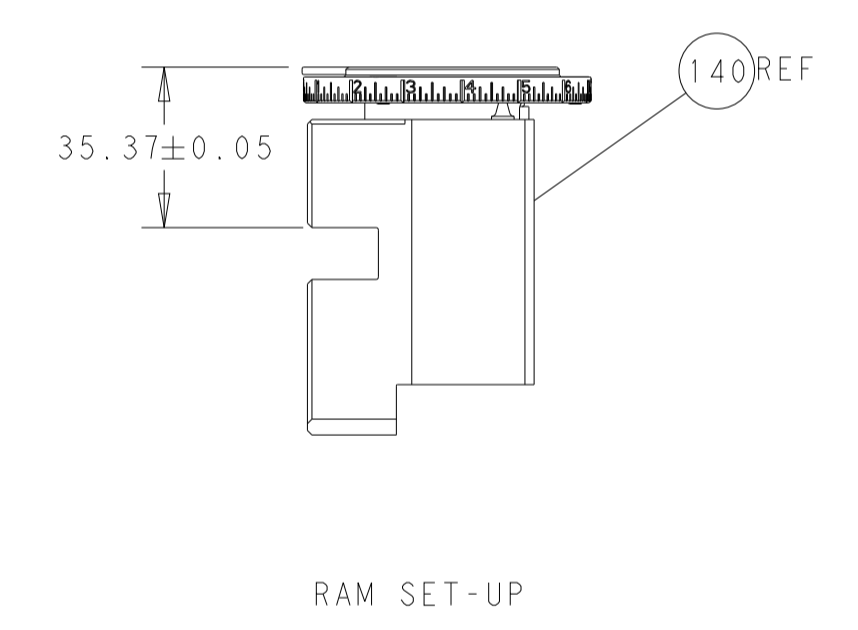
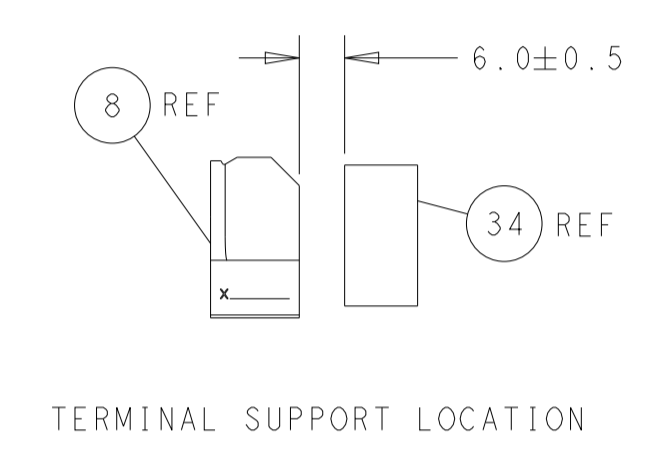
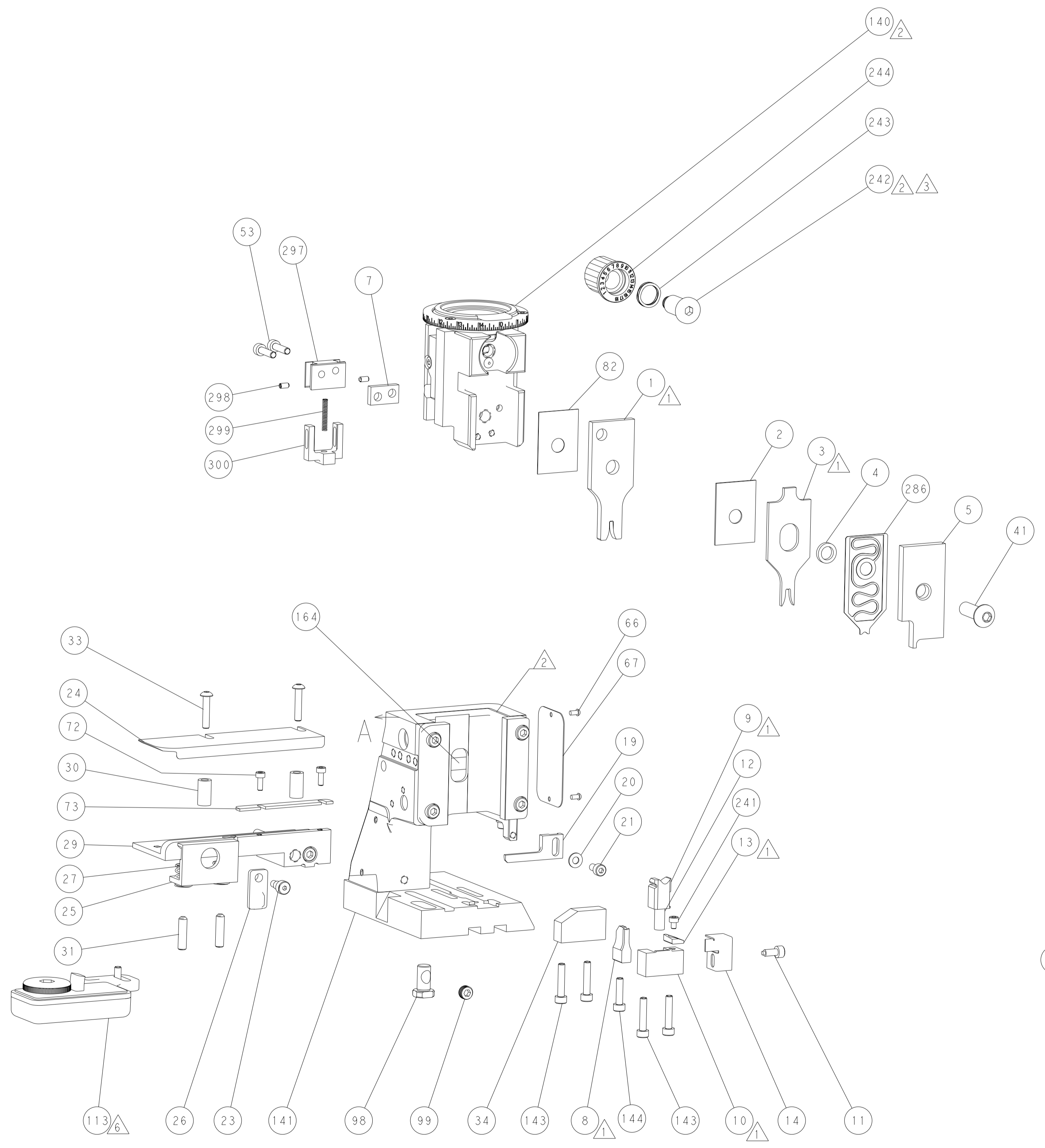

PACIFIC VERSION
 Shown on sheets 3 of 4 & 4 of 4
 (Atlantic version shown on sheets 1 of 4 & 2 of 4)

DIMENSIONS:		TOLERANCES UNLESS OTHERWISE SPECIFIED:		DWN Y. YIN 18AUG2011		TE Connectivity	
mm	0 PLC ±	1 PLC ±	2 PLC ±	3 PLC ±	4 PLC ±	Harrisburg, PA 17105-3608	
MATERIAL:	FINISH:	WEIGHT:		A 00779 ©=2151182		RESTRICTED TO	
CUSTOMER ACCESSIBLE PRODUCTION DRAWING				SCALE 1:2	SHEET 4 OF 4	REV G	