

NOTES:

1. CARRIER MATL: COPPER ALLOY, 0.30 MM THICKNESS;
2. FINISHED: REFER TO P/N SYSTEM;
3. UNLESS OTHERWISE SPECIFIED, ALL INNER RADII ARE R0.10mm;
4. DIMENSIONING SHALL BE INTERPRETED PER ASME Y14.5-2009;
5. PACKING: 5KPCS/REEL, REF TO SPEC. GS-14-2813;
6. APPLICABLE HOUSING: 10162695 SERIES;
7. APPLICATION SPEC.: GS-20-0703;
8. PART NUMBER CODE:
101162697-X0XLF

APPLICABLE WIRES:
2: AWG #18~20

RESERVE NUMBER

PLATING SPEC:
0: 5u" MIN. Au ON CONTACT AREA
Gold flash ON CRIMPING AREA

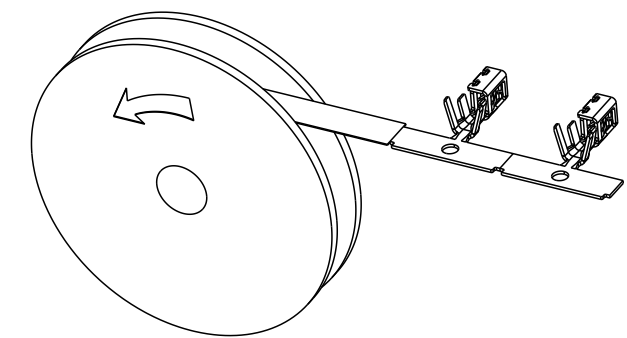
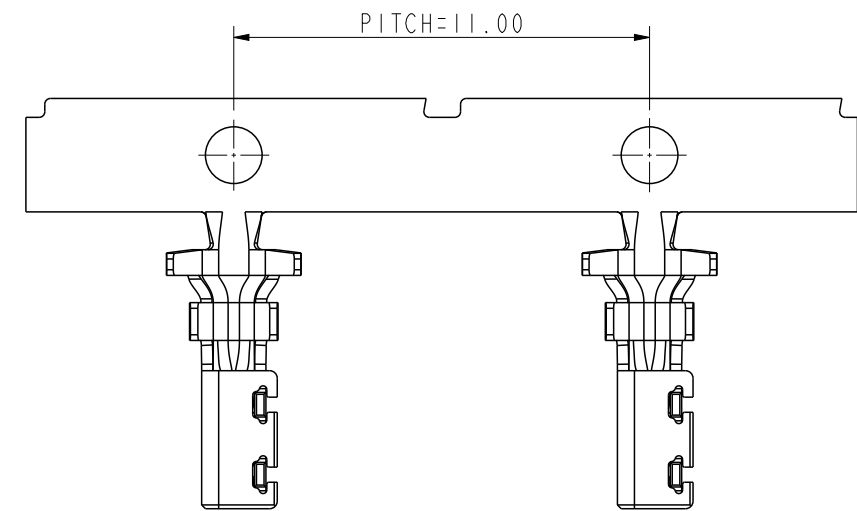

REELING DIRECTION AFTER PLATING

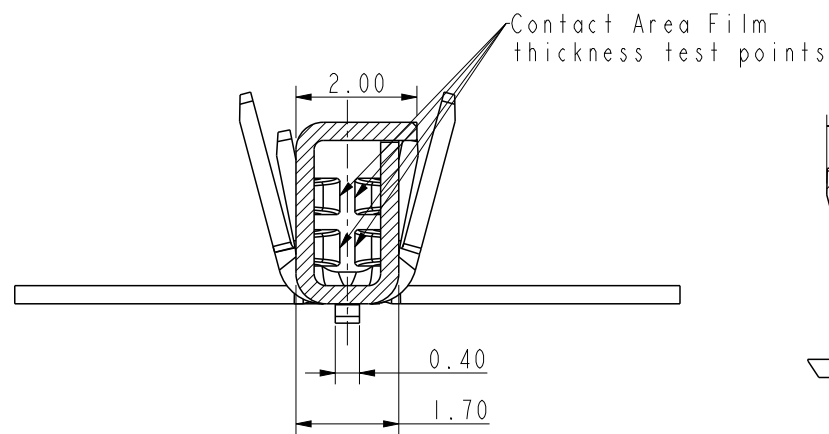
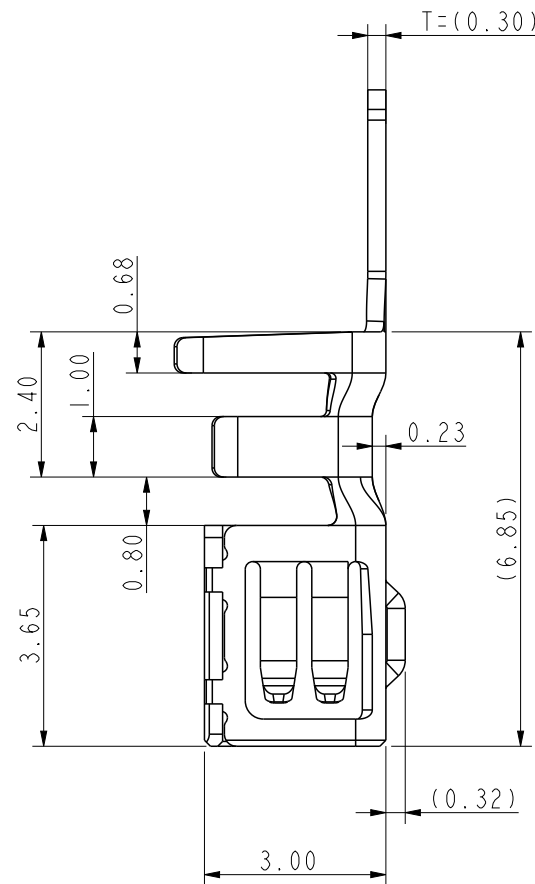
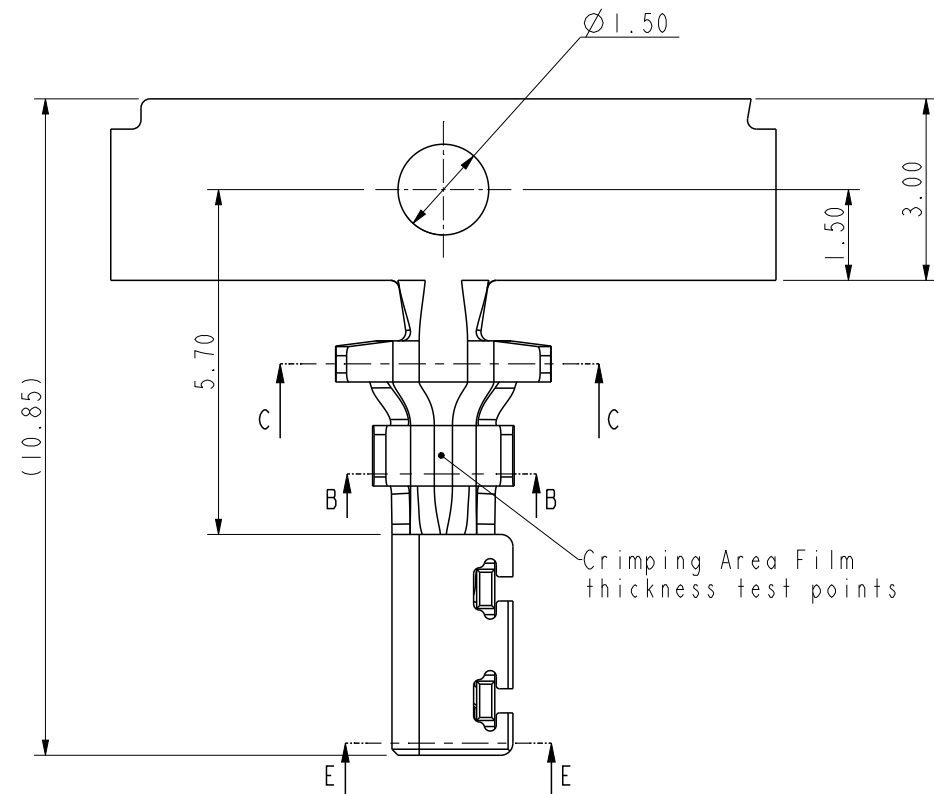

SECTION E-E

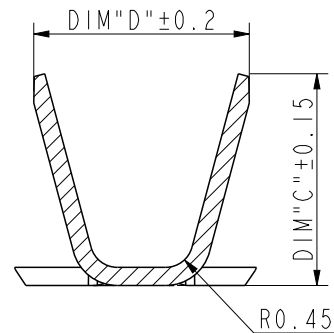

SECTION C-C
SCALE 8:1

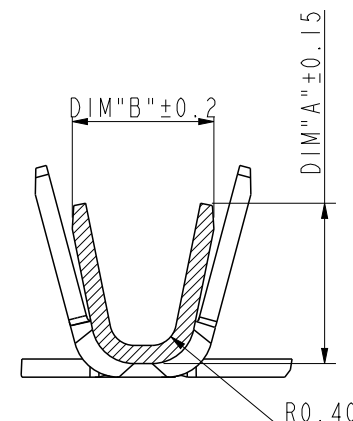

SECTION B-B
SCALE 8:1

10162697-X02LF	2.65	2.34	3.50	3.56	AWG #18~20
PART NO.	DIM.A	DIM.B	DIM.C	DIM.D	APPLICABLE WIRES

spec ref	dr	Arthur Zhao	2021/09/22	projection	mm	size	A3	scale	N/A
tolerance std	eng	Ji-Feng Zhang	2022/05/20			ecn no	ELX-N-44775-1		
ISO 406 ISO 1101	chr	-	-			rel level	Released		
surface	linear	0.X	±0.30			title Rec Power Terminal ComboLock WTB connector	dwg no 10162697C	rev C	
		0.XX	±0.15						
ISO 1302	angular	0°	±2°	product family	-	cat. no.	-	Product - Customer Drw	sheet 1 of 1