



## ARM Cortex<sup>®</sup>-M4 32-BIT MICROCONTROLLER

# NuTiny-SDK-NUC442 User Manual for NuMicro<sup>™</sup> NUC442 Series

*The information described in this document is the exclusive intellectual property of Nuvoton Technology Corporation and shall not be reproduced without permission from Nuvoton.*

*Nuvoton is providing this document only for reference purposes of NuMicro<sup>™</sup> microcontroller based system design. Nuvoton assumes no responsibility for errors or omissions.*

*All data and specifications are subject to change without notice.*

*For additional information or questions, please contact: Nuvoton Technology Corporation.*



## Table of Contents

1	Overview .....	3
2	Introduction to NuTiny-SDK-NUC442 .....	3
2.1	NuTiny-SDK-NUC442 System Description.....	5
2.2	Pin Assignment for Extended Connectors .....	7
2.3	NuTiny-SDK-NUC442 PCB Placement.....	10
3	Starting to Use NuTiny-SDK-NUC442 on the Keil $\mu$ Vision <sup>®</sup> IDE .....	11
3.1	Downloading and Installing Keil $\mu$ Vision <sup>®</sup> IDE Software .....	11
3.2	Downloading and Installing Nuvoton Nu-Link Driver .....	11
3.3	Hardware Setup.....	11
3.4	Example Program.....	12
4	Starting to Use NuTiny-SDK-NUC442 on the IAR Embedded Workbench ..	13
4.1	Downloading and Installing IAR Embedded Workbench Software.....	13
4.2	Downloading and Installing Nuvoton Nu-Link Driver .....	13
4.3	Hardware Setup.....	13
4.4	Example Program.....	14
5	NuTiny-SDK-NUC442 Schematics .....	15
5.1	NuTiny-EVB-NUC442 Schematic.....	15
5.2	Nu-Link-Me Schematic.....	20
6	Downloading NuMicro <sup>™</sup> Related Files from Nuvoton Website .....	21
6.1	Downloading NuMicro <sup>™</sup> Keil $\mu$ Vision <sup>®</sup> IDE Driver .....	21
6.2	Downloading NuMicro <sup>™</sup> IAR EWARM Driver .....	23
6.3	Downloading NuMicro <sup>™</sup> NUC442 Series BSP Software Library .....	25
7	Revision History .....	26

## 1 Overview

The NuTiny-SDK-NUC442 is a specific development tool for NuMicro™ NUC442 Series. User can use NuTiny-SDK-NUC442 to develop and verify the application program easily. The NuTiny-SDK-NUC442 includes two parts: NuTiny-EVB-NUC442 and Nu-Link-Me. The NuTiny-EVB-NUC442 is the evaluation board and Nu-Link-Me is its Debug Adaptor. Therefore, user does not need other additional ICE or debug equipment.

## 2 Introduction to NuTiny-SDK-NUC442

The NuTiny-SDK-NUC442 uses the NUC442JI8AE as the target microcontroller. Figure 2-1 shows the NuTiny-SDK-NUC442 for NUC442 Series, in which the left portion is called NuTiny-EVB-NUC442 and the right portion is called Nu-Link-Me.

The NuTiny-EVB-NUC442 is similar to other development boards. User can use it to develop and verify applications to emulate the real behavior. The on-board chip covers NUC442 Series features. The NuTiny-EVB-NUC442 can be a real system controller to design users' target systems.

The Nu-Link-Me is a Debug Adaptor, which connects your PC's USB port to your target system (via Serial Wired Debug port) and allows you to program and debug embedded programs on the target hardware. To use the Nu-Link-Me Debug Adaptor with IAR or Keil, please refer to the “Nuvoton NuMicro™ IAR ICE Driver User Manual” or “Nuvoton NuMicro™ Keil ICE Driver User Manual” for details. The two documents will be stored in the local hard disk when each driver is installed.

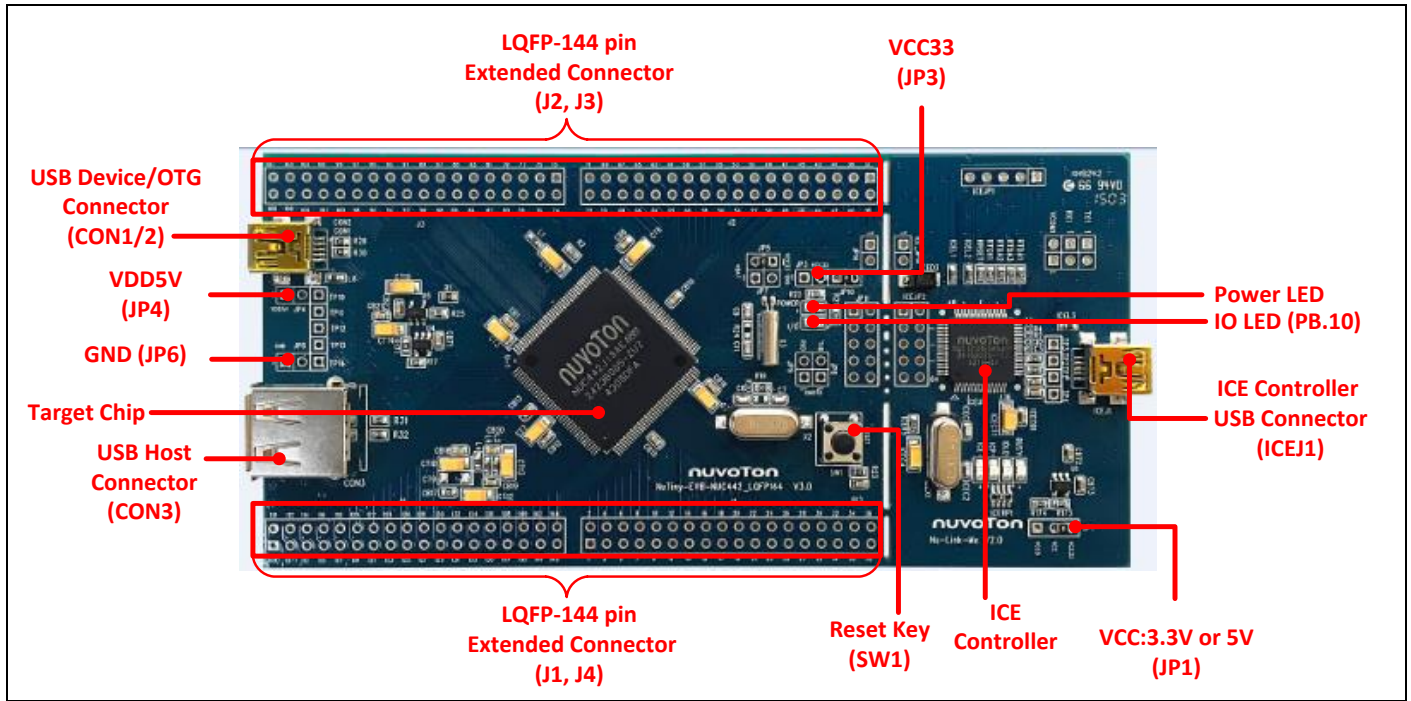

Figure 2-1 NuTiny-SDK-NUC442 (Blue PCB Board)



## 2.1 NuTiny-SDK-NUC442 System Description

### 2.1.1 Power Settings

- **ICEJ1**: USB port in Nu-Link-Me
- **CON2**: Mini USB port in NuTiny-EVB-NUC442
- **JP4/JP14**: VDD5V voltage connector in NuTiny-EVB-NUC442

POWER Mode	ICEJ1 USB Port (Mini)	CON2 USB Port (Mini)	JP4/JP14 VDD5V	MCU Voltage	Comment
Mode 1	Connected to PC	X	DC 5V Output	DC 3.3 V	ICEJ1 (from PC) supplies the power.
Mode 2	X	Connect to PC (USB port is device)	DC 5V Output	DC 3.3 V	CON2 (from PC) supplies the power when TP10 is wired to JP4 or JP14.
Mode 3	X	X	DC 5V Input	DC 3.3V	JP4 or JP14 supplies the power.

X: Unused.

### 2.1.2 Debug Connectors

- **JP11**: The connector in the target board (NuTiny-EVB-NUC442) for connecting with Nuvoton ICE adaptor (Nu-Link, Nu-Link-Pro or Nu-Link-Me)
- **ICEJP2**: The connector in the ICE adaptor (Nu-Link-Me) for connecting with a target board (e.g. NuTiny-EVB-NUC442)

### 2.1.3 USB Connector

- **ICEJ1**: Mini USB connector in Nu-Link-Me connected to a PC USB port

### 2.1.4 USB Device/OTG Connector (The default is Device Connector (Mini))

- **CON1/CON2**: Mini/Micro USB connector in NuTiny-EVB-NUC442 for application use

### 2.1.5 USB Host Connector

- **CON3**: USB Type-A connector in NuTiny-EVB-NUC442 for application use

### 2.1.6 Extended Connectors

- **J1, J2, J3** and **J4**: Show all chip pins in NuTiny-EVB-NUC442

### 2.1.7 Reset Button

- **SW1**: Reset button in NuTiny-EVB-NUC442. Press this key to reset the target chip

NUC442JI8AE.

## 2.1.8 Power Connectors

- **JP3:** VCC33 connector in NuTiny-EVB-NUC442 to supply the 3.3V voltage input to target board
- **JP10:** An option to select whether the 3.3V voltage input supplied by the ICE bridge (default)
- **VBAT:** The VBAT connector in NuTiny-EVB-NUC442 to supply an extra battery power. The default is shorted with VCC33.
- **JP4/JP14:** VDD5V connector in NuTiny-EVB-NUC442 to supply 5V voltage input from an extra power supplier.
- **JP6:** GND connector in NuTiny-EVB-NUC442



## 2.2 Pin Assignment for Extended Connectors

The NuTiny-EVB-NUC442 provides the NUC442JI8AE target chip on board and the extended connectors (**JP1**, **JP2**, **JP3** and **JP4**) for LQFP 144-pin.

No	Pin Name	No	Pin Name
1	PE.12/EBI_nCS1/ACMP2_P2/ACMP1_P3/ADC1_4	24	PD.3/EBI_A7/CAP_DATA0/SD0_CDn/ACMP2_O/I2C3_SDA/SC5_CLK
2	PE.13/EBI_nCS2/ACMP2_P1/ADC1_5	25	PD.4/EBI_A8/CAP_SCLK/ACMP1_O/UART3_RXD/SC5_CD
3	PE.14/EBI_nCS3/ACMP2_P0/ADC1_6	26	PD.5/EBI_A9/CAP_VSYNC/UART3_TXD/SC5_RST
4	PE.15/ACMP2_N/ADC1_7	27	PD.6/EBI_A10/CAP_HSYNC/SD0_CMD/UART3_RTS/SC5_PWR
5	PF.9/PWM0_0/OPA0_IN+	28	PD.7/EBI_A11/CAP_PIXCLK/SD0_CLK/UART3_CTS/SC5_DAT
6	PF.10/PWM0_1/OPA0_IN-	29	PG.13/XT1_IN
7	PF.11/UART1_RTS/OPA0_O	30	PG.12/XT1_OUT
8	PF.12/UART1_CTS/OPA1_IN+	31	nRESET
9	PF.13/UART1_TXD/OPA1_IN-	32	LDO_CAP
10	PF.14/UART1_RXD/OPA1_O	33	VSS
11	VSS	34	VDD
12	VDD	35	PG.10/ICE_CLK
13	PF.15/UART0_RTS	36	PG.11/CE_DAT
14	PG.0/INT6/UART0_CTS	37	PG.15/X32K_IN/I2C1_SCL
15	PG.1/UART0_RXD	38	PG.14/X32K_OUT/I2C1_SDA
16	PG.2/UART0_TXD	39	VBAT
17	PC.12/EBI_A0/CAP_DATA7/SD1_CDn/SC4_CD/SPI1_SS0	40	PA.0/TAMPER0/SC0_CD/CAN1_RXD/INT0
18	PC.13/EBI_A1/CAP_DATA6/SD1_CMD/SC4_RST/SPI1_MOSI1	41	PA.1/TAMPER1/SC5_CD/CAN1_TXD/EBI_A22
19	PC.14/EBI_A2/CAP_DATA5/SD1_CLK/TM3_EXT/SC4_PWR/SPI1_MISO1	42	PD.8/SPI3_MISO1/I2C0_SCL
20	PC.15/EBI_A3/CAP_DATA4/SD1_DAT3	43	PD.9/SPI3_MOSI1/I2C0_SDA
21	PD.0/INT3/EBI_A4/CAP_DATA3/SD1_DAT2/SC4_CLK/SPI1_MISO0	44	PA.2/SC2_DAT/SPI3_MISO0/I2S0_MCLK/BRAKE11/CAP_SFIELD/EBI_A12
22	PD.1/EBI_A5/CAP_DATA2/SD1_DAT1/TM0_CNT_OUT/SPI1_CLK	45	PA.3/SC2_CLK/SPI3_MOSI0/I2S0_DO/BRAKE10/EBI_A13
23	PD.2/EBI_A6/CAP_DATA1/SD1_DAT0/I2C3_SCL/STADC	46	PA.4/SC2_PWR/SPI3_CLK/I2S0_DI/QEI1_Z/EBI_A14/ECAP1_IC2



47	PA.5/SC2_RST/SPI3_SS0/I2S0_BCLK/PWM0_0/ QEI1_B/EBI_A15/ECAP1_IC1	73	PD.13/SPI1_SS0/UART5_CTS/ECAP0_IC2
48	PA.6/SC2_CD/I2S0_LRCK/PWM0_1/QEI1_A/ CAN1_TXD/EBI_A16/ECAP1_IC0	74	PD.14/SPI1_CLK/UART5_RTS/ECAP0_IC1
49	PG.3/PS2_CLK/I2S1_DO/SC1_RST	75	PD.15/SPI1_MISO0/UART5_TXD/ECAP0_IC0
50	PG.4/PS2_DAT/I2S1_DI/SC1_PWR	76	PF.0/SPI1_MOSI0/UART5_RXD/INT5
51	PG.5/I2S1_BCLK/SC1_DAT	77	VRES
52	PG.6/I2S1_LRCK/SC1_CLK	78	VBUS
53	VDD	79	USB_VDD33_CAP
54	VSS	80	VSSA
55	PA.7/SC0_CLK/SPI3_SS0/PWM1_3/EPWM0_5/ EBI_A17	81	USB0_D-
56	PA.8/SC0_RST/SPI3_CLK/PWM1_2/EPWM0_4/ EBI_A18	82	USB0_D+
57	PA.9/SC0_PWR/SPI3_MISO0/PWM1_1/ EPWM0_3/EBI_A19	83	USB0_OTG_ID
58	PA.10/SC0_DAT/SPI3_MOSI0/PWM1_0/ EPWM0_2/EBI_A20	84	PB.0/USB0_OTG5V_ST/I2C4_SCL/INT1
59	PA.11/UART0_RTS/SPI3_MISO1/PWM0_5/ EPWM0_1/EBI_AD0	85	PB.1/USB0_OTG5V_EN/I2C4_SDA/ TM1_CNT_OUT
60	PA.12/UART0_CTS/SPI3_MOSI1/PWM0_4/ EPWM0_0/EBI_AD1	86	PG.7/SPI2_MISO0/I2S1_MCLK/SC1_CD/SC3_RST
61	PA.13/UART0_RXD/SC3_DAT/PWM1_4/EBI_AD2	87	PG.8/SPI2_MOSI0/I2S1_DO/UART4_RTS/ SC3_DAT
62	PA.14/UART0_TXD/SC3_CLK/PWM1_5/EBI_AD3	88	PG.9/SPI2_CLK/I2S1_DI/UART4_CTS/SC3_CLK
63	PD.10/SC3_DAT/I2C4_SCL	89	PB.2/UART1_RXD/SPI2_SS0/USB1_D-/EBI_AD4
64	PD.11/SC3_RST/TM3_CNT_OUT	90	PB.3/UART1_TXD/SPI2_CLK/USB1_D+/EBI_AD5
65	PD.12/SC3_CLK/I2C4_SDA	91	PB.4/UART1_RTS/SPI2_MISO0/UART4_RXD/ TM0_CNT_OUT/EBI_AD6
66	PA.15/SC3_PWR/UART2_RTS/I2C0_SCL/EBI_A21	92	PB.5/UART1_CTS/SPI2_MOSI0/UART4_TXD/ EBI_AD7
67	PC.9/STADC/UART2_CTS/SC3_RST/I2C0_SDA/ CAP_DATA1/I2C3_SCL/EBI_A22/SD1_DAT0/EBI_ A6	93	PB.6/I2C2_SCL/BRAKE01/UART4_RTS/PWM1_4/ EPWM1_0/EBI_AD8
68	PC.10/SC3_CD/UART2_RXD/PWM0_2/EBI_A23/ EBI_AD2	94	PB.7/I2C2_SDA/BRAKE00/UART4_CTS/PWM1_5/ EPWM1_1/EBI_AD9
69	PC.11/UART2_TXD/UART2_TXD/PWM0_3/ EBI_A24/EBI_AD3	95	PB.8/UART5_CTS/EPWM1_2/EBI_AD10
70	LDO_CAP	96	PB.9/UART5_RTS/EPWM1_3/EBI_AD11
71	VSS	97	PB.10/UART5_TXD/EPWM1_4/EBI_AD12
72	VDD	98	PB.11/UART5_RXD/EPWM1_5/EBI_AD13





99	PH.0/I2C1_SCL/UART4_RXD/CAN1_RXD/INT7	122	VDD
100	PH.1/UART4_TXD/I2C1_SDA/CAN1_TXD	123	PF.6/SD0_CDn/UART2_RXD
101	PB.12/UART4_RTS/SPI2_MISO1/CAN0_RXD/ EBI_AD14	124	PF.7/SD0_CMD/UART2_TXD
102	PB.13/UART4_CTS/SPI2_MOSI1/CAN0_TXD/ EBI_AD15	125	PF.8/SD0_CLK/UART2_RTS
103	PB.14/I2S1_MCLK/SC1_RST/BRAKE01	126	PH.2/UART2_CTS
104	PB.15/I2S1_DO/SC1_DAT/BRAKE00	127	LDO_CAP
105	VDD	128	VSS
106	VSS	129	VDD
107	LDO_CAP	130	PE.0/INT4/ADC0_0/
108	PC.0/I2S1_DI/SC1_DAT/UART4_RXD/EBI_MCLK/ INT2	131	PE.1/TM2_CNT_OUT/ADC0_1
109	PC.1/EBI_AD13/TM3_CNT_OUT/UART4_TXD/ SC1_CLK/I2S1_BCLK	132	PE.2/SPI0_MISO0/ACMP0_O/ADC0_2
110	PC.2/EBI_AD12/SPI0_SS0/UART4_RTS/ SC1_PWR/I2S1_LRCK	133	PE.3/SPI0_MOSI0/ACMP0_P3/ADC0_3
111	PC.3/ECAP0_IC2/EBI_AD11/QEI0_Z/SPI0_MISO1/ UART4_CTS/SC1_CD/I2S1_MCLK	134	PE.4/SPI0_SS0/ACMP0_P2/ADC0_4
112	PC.4/ECAP0_IC1/EBI_AD10/QEI0_B/SPI0_MOSI1/ SC1_RST/I2S1_DO	135	PE.5/SD0_CDn/SPI0_CLK/ACMP0_P1/ADC0_5
113	PC.5/ECAP0_IC0/EBI_MCLK/QEI0_A/CLKO	136	PE.6/EBI_nWR/SD0_CMD/SPI0_MISO0/ ACMP0_P0/ADC0_6
114	PC.6/EBI_AD9/TM2_CNT_OUT/SPI0_MISO0 TM2_EXT	137	PE.7/EBI_nRD/SD0_CLK/SPI0_MOSI0/ ACMP0_N/ADC0_7
115	PC.7/EBI_AD8/SPI0_MOSI0/TM1_EXT	138	AVSS
116	PC.8/SPI0_CLK/TM0_EXT	139	Vref
117	PF.2/SD0_DAT3/SPI3_SS0	140	AVDD
118	PF.3/SD0_DAT2/SPI3_CLK	141	PE.8/EBI_ALE/SD0_DAT3/TM1_CNT_OUT/ ACMP1_N/ADC0_8/ADC1_0
119	PF.4/SD0_DAT1/SPI3_MISO0	142	PE.9/EBI_nWRH/SD0_DAT2/ACMP1_P0/ADC0_9/ ADC1_1
120	PF.5/SD0_DAT0/SPI3_MOSI0	143	PE.10/EBI_nWRL/SPI0_MISO1/ACMP1_P1/ ADC0_10/ADC1_2
121	VSS	144	PE.11/EBI_nCS0/ACMP2_P3/SD0_DAT0/ SPI0_MOSI1/ACMP1_P2/ADC0_11/ADC1_3

Table 2-1 NUC442JI8AE LQFP 144-pin Assignment for Extended Connectors



### 3 Starting to Use NuTiny-SDK-NUC442 on the Keil $\mu$ Vision<sup>®</sup> IDE

#### 3.1 Downloading and Installing Keil $\mu$ Vision<sup>®</sup> IDE Software

Please connect to the Keil company website (<http://www.keil.com>) to download the Keil  $\mu$ Vision<sup>®</sup> IDE and install the RVMDK.

#### 3.2 Downloading and Installing Nuvoton Nu-Link Driver

Please connect to Nuvoton NuMicro<sup>™</sup> website (<http://www.nuvoton.com/NuMicro>) to download the “NuMicro<sup>™</sup> Keil  $\mu$ Vision<sup>®</sup> IDE driver” file. Please refer to *section 6.1* for the detailed download flow. After the Nu-Link driver is downloaded, please unzip the file and execute the “Nu-Link\_Keil\_Driver.exe” to install the driver.

#### 3.3 Hardware Setup

The hardware setup is shown in the following figure.



Figure 3-1 NuTiny-SDK-NUC442 Hardware Setup



## 3.4 Example Program

This example, as shown in the directory in Figure 3 2, demonstrates downloading and debugging an application on a NuTiny-SDK-NUC442 board. The example file can be downloaded from Nuvoton NuMicro™ website as described in section 6.3.

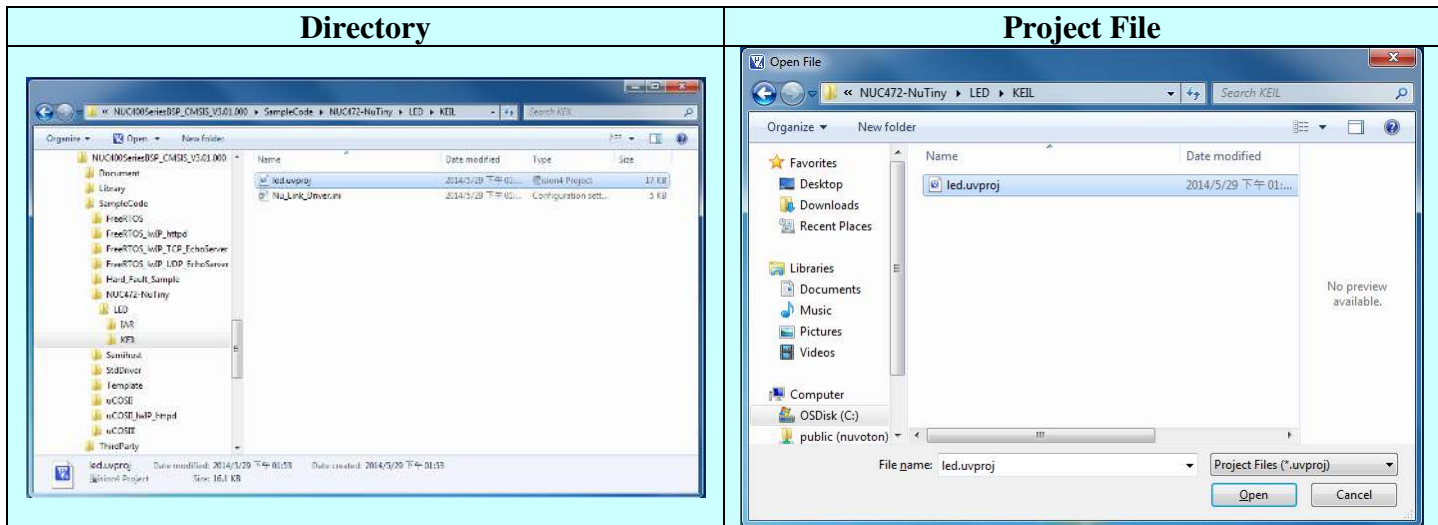









Figure 3-2 Example Directory

To use the example:

The I/O LED on the NuTiny-EVB-NUC442 board will be toggled on.

-  **Start µVision®**
- **Project – Open**  
Open the led.uvproj project file
-  **Project – Build**  
Compile and link the LED application
-  **Flash – Download**  
Program the application code into on-chip Flash ROM
-  **Start Debug mode**  
When using the debugger commands, you may:
  - ◆  Review variables in the watch window
  - ◆  Single step through code
  - ◆  Reset the device
  - ◆  Run the application

## 4 Starting to Use NuTiny-SDK-NUC442 on the IAR Embedded Workbench

### 4.1 Downloading and Installing IAR Embedded Workbench Software

Please connect to IAR company website (<http://www.iar.com>) to download the IAR Embedded Workbench and install the EWARM.

### 4.2 Downloading and Installing Nuvoton Nu-Link Driver

Please connect to Nuvoton Company NuMicro™ website (<http://www.nuvoton.com/NuMicro>) to download “NuMicro™ IAR EWARM Driver” file. Please refer to section 6.2 for the detail download flow. After the Nu-Link driver is downloaded, please unzip the file and execute the “Nu-Link\_IAR\_Driver.exe” to install the driver.

### 4.3 Hardware Setup

The hardware setup is shown in the following figure.



Figure 4-1 NuTiny- SDK-NUC442 Hardware Setup



## 4.4 Example Program

This example, as shown in the directory in Figure 4-2, demonstrates downloading and debugging an application on a NuTiny-SDK-NUC442 board. The example file can be downloaded from Nuvoton NuMicro™ website as described in *section 6.3*.

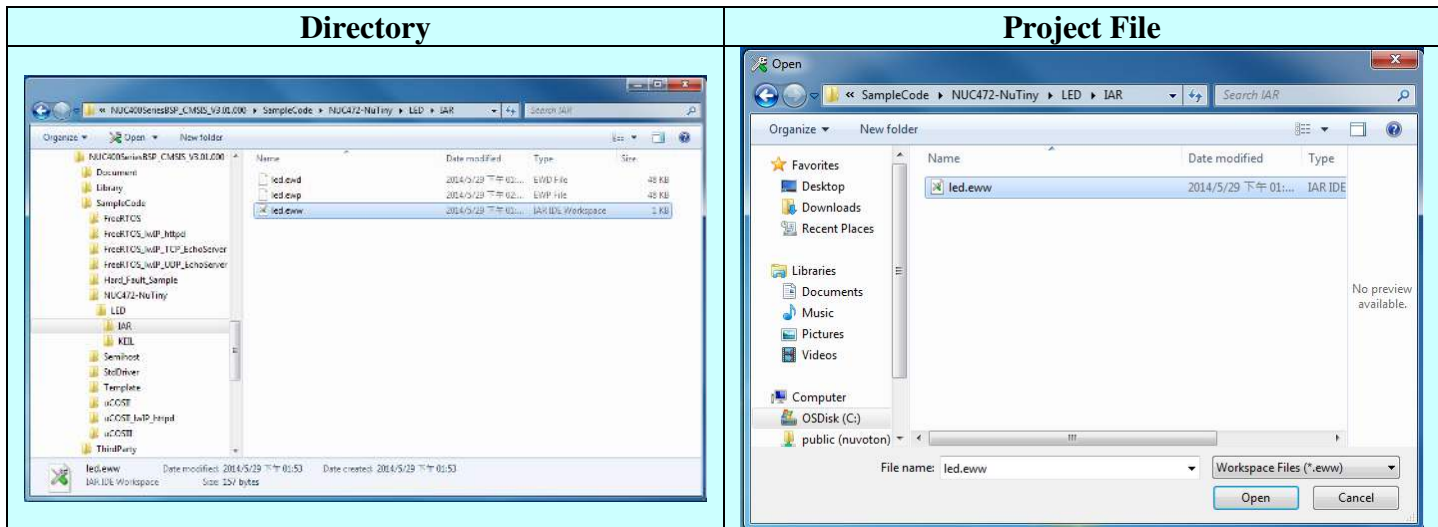







Figure 4-2 Example Directory

To use the example:

The I/O LED on the NuTiny-EVB-NUC442 board will be toggled on.

-  **Start IAR Embedded Workbench**
- **File-Open-Workspace**  
Open the led.eww workspace file
-  **Project - Make**  
Compile and link the LED application
-  **Project – Download and Debug**  
Program the application code into on-chip Flash ROM
  - ◆  Single step through code
  - ◆  Reset the device
  - ◆  Run the application





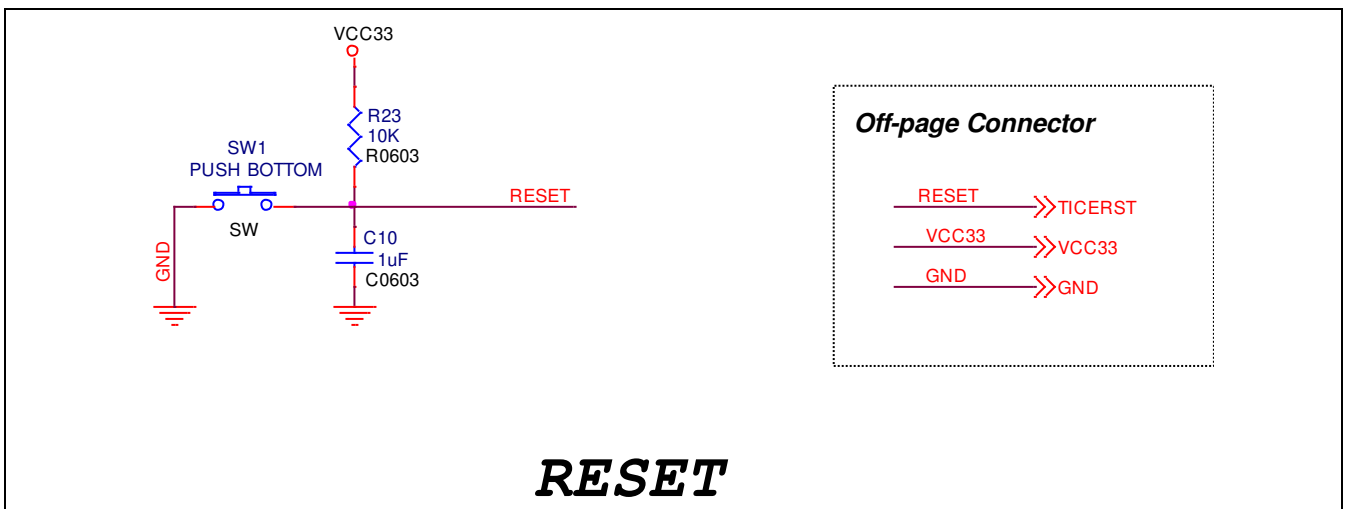
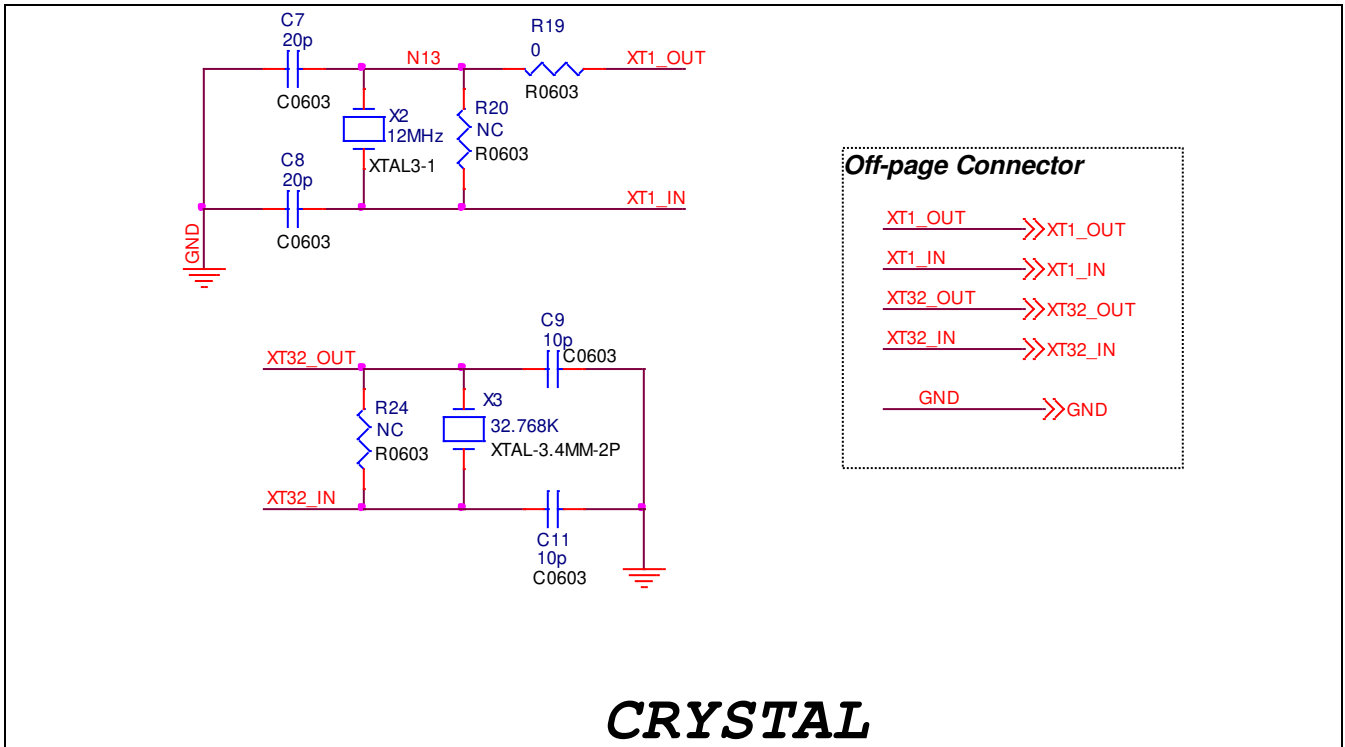



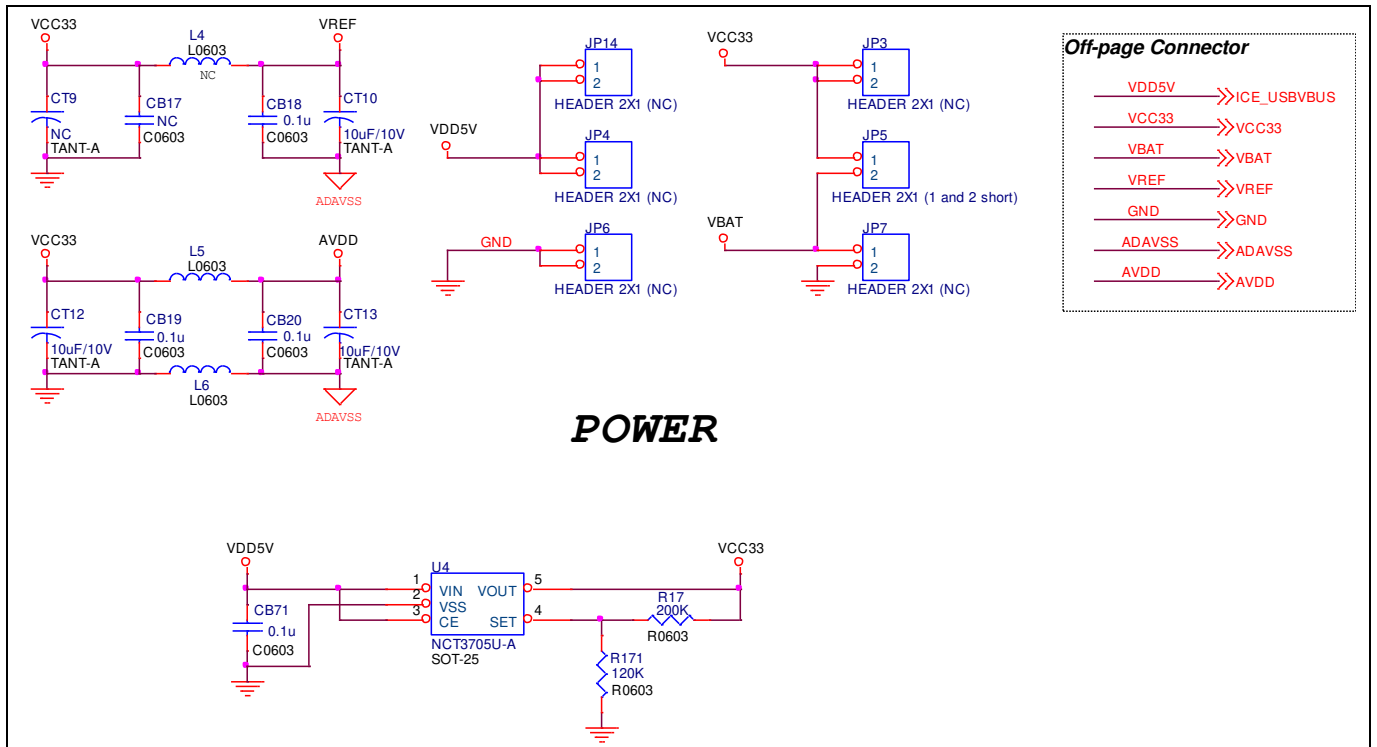
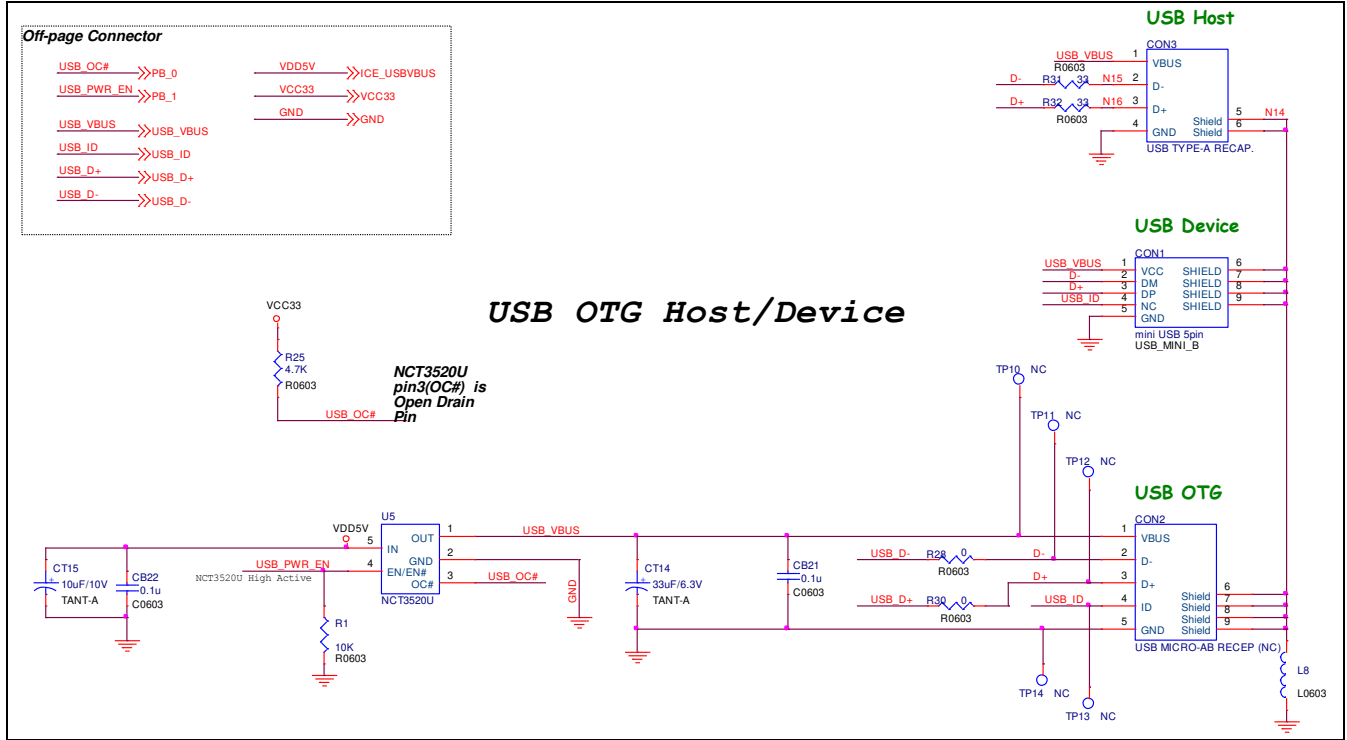

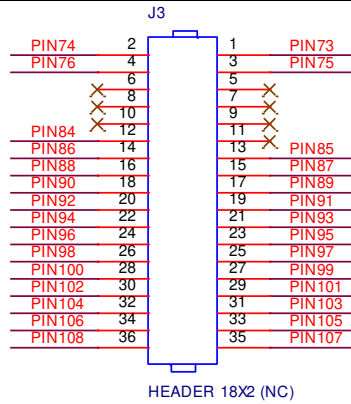
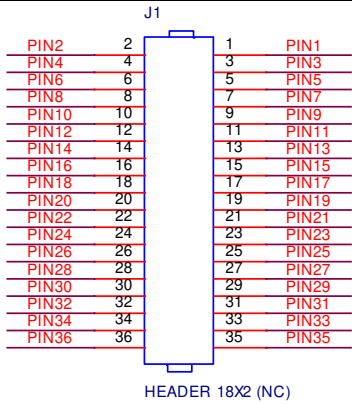

## PIN CONNECTOR

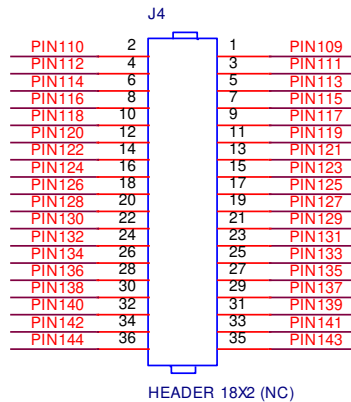
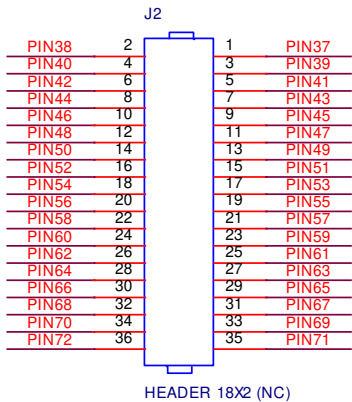

Off-page Connector



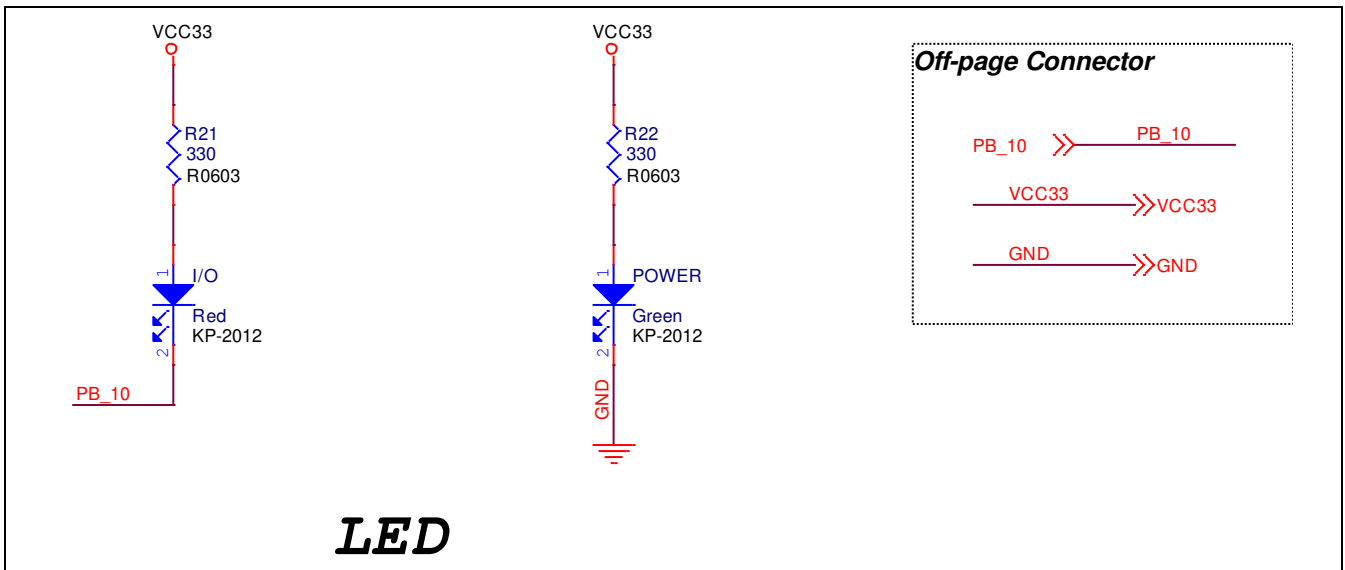
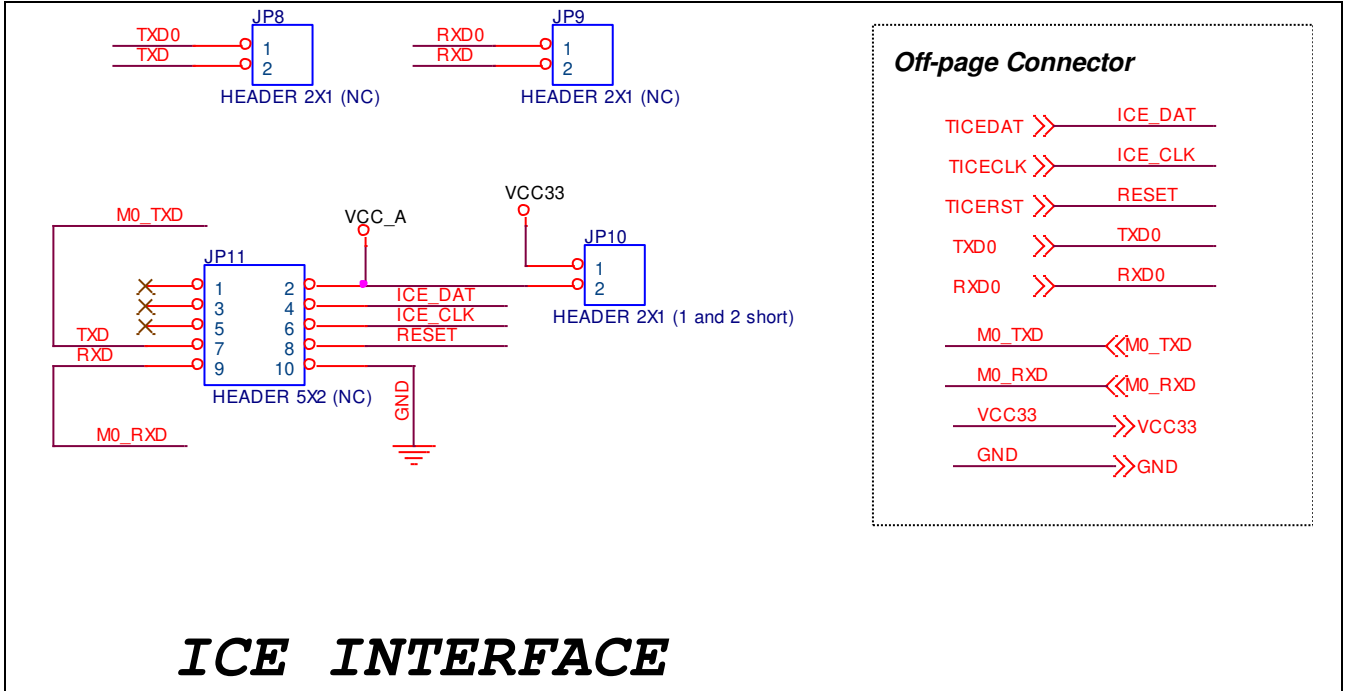



## 5.2 Nu-Link-Me Schematic

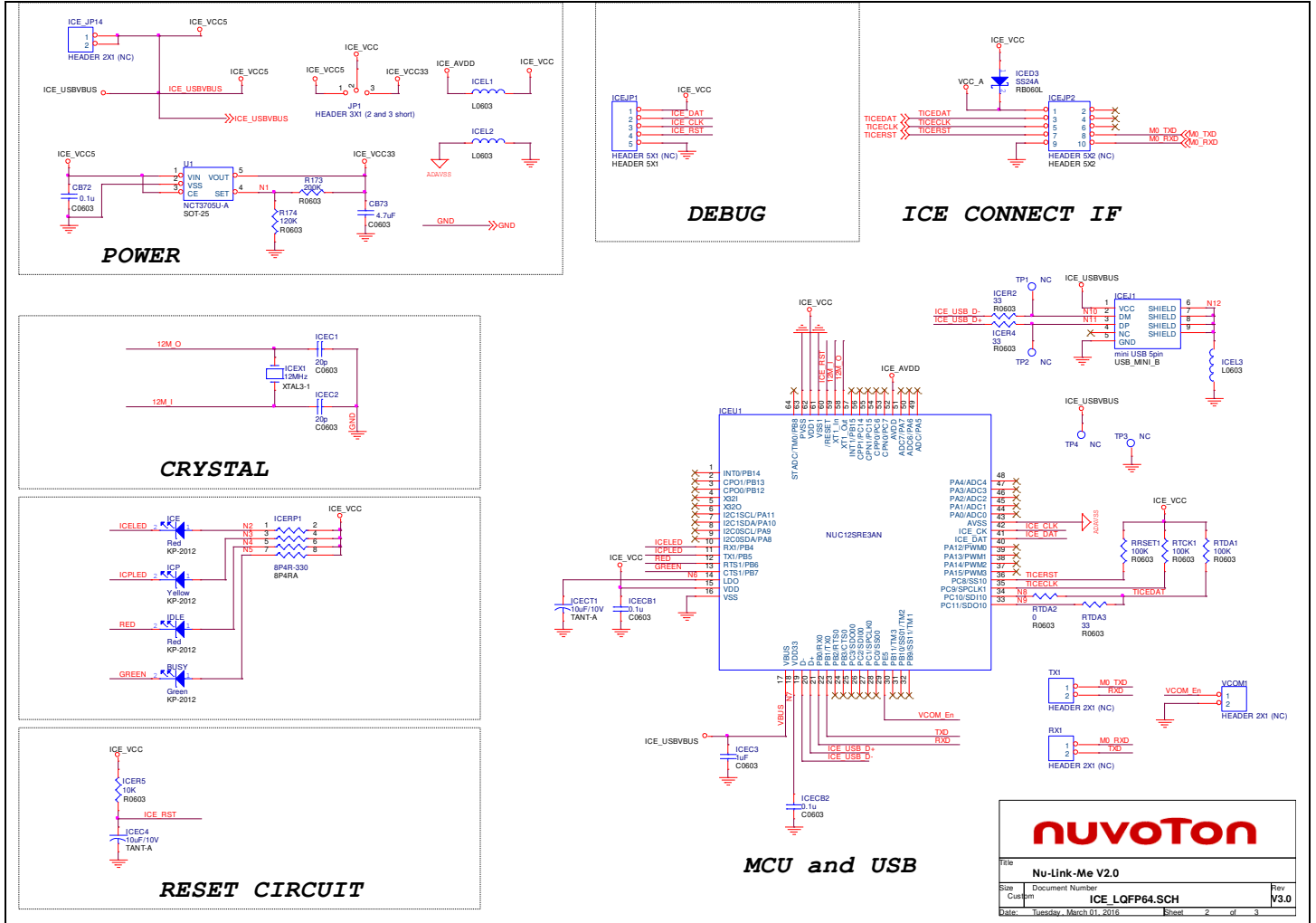



## 6 Downloading NuMicro™ Related Files from Nuvoton Website

### 6.1 Downloading NuMicro™ Keil μVision® IDE Driver

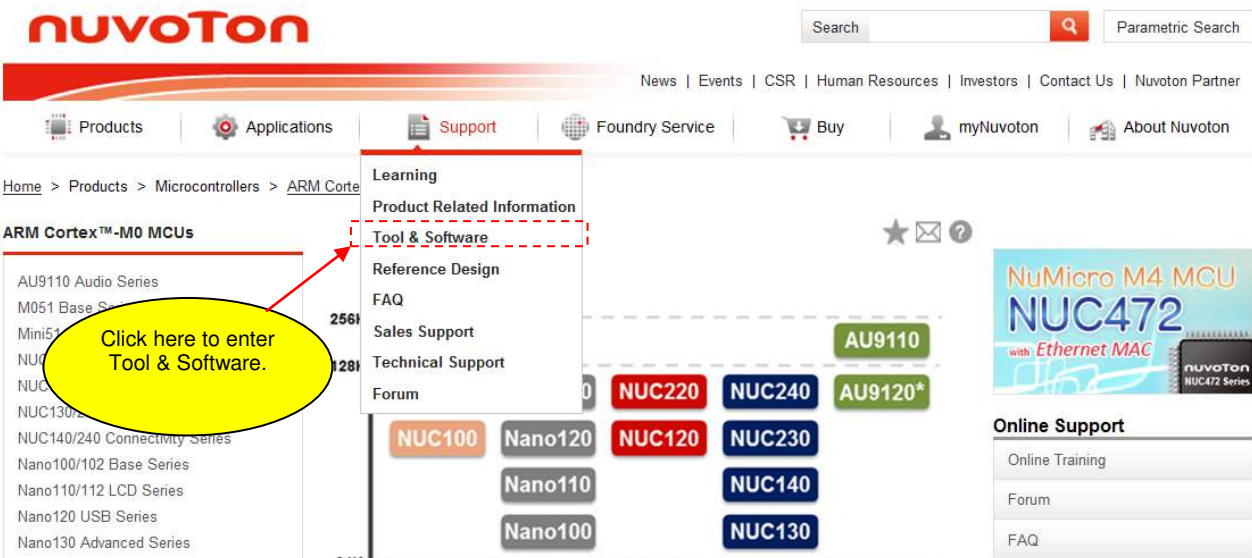
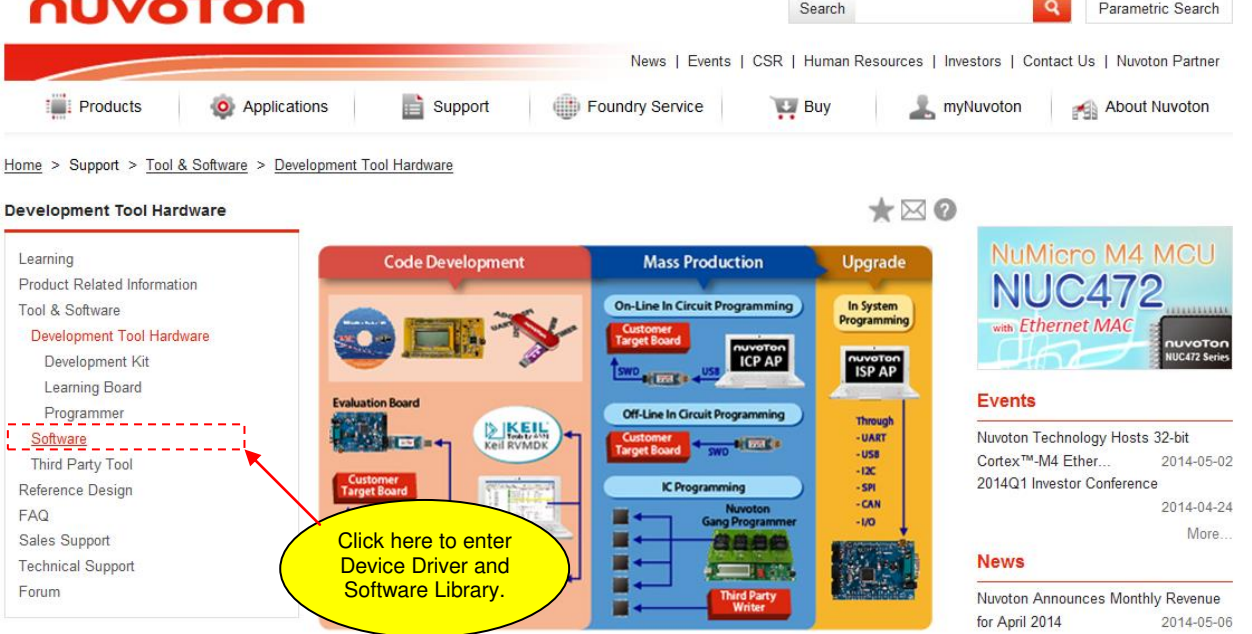
<p><b>Step1</b></p>	<p>Visit the Nuvoton NuMicro™ website: <a href="http://www.nuvoton.com/NuMicro">http://www.nuvoton.com/NuMicro</a></p>
<p><b>Step2</b></p>	
<p><b>Step3</b></p>	

**Step4**

*Programmer Software Tools Package*

File name	Description	Version	Date
ICP Programming Tool V1.25.6287.zip Revision History	NuMicro ICP tool & user manual	V1.25.6287	2014-01-16
ISP Programming Tool V1.44.zip Revision History	NuMicro ISP Programming Tool & user manual	V1.44	2014-01-20
NuGang Programmer V6.21.zip Revision History	NuGang Programmer software & user manual	V6.21	2014-01-24

*Nu-Link Driver*

File name	Description	Version	Date
Nu-Link Driver for Keil RVMDK V1.25.6287.zip Revision History	This driver is to support Nu-Link to work under Keil RVMDK Development Environment for all NuMicro Family Devices.	V1.25.6287	2014-01-16
Nu-Link Driver for IAR EWARM V1.25.6287.zip Revision History	This driver is to support Nu-Link to work under IAR EWARM Development Environment for all NuMicro Family Devices.	V1.25.6287	2014-01-16



Click here to download the file.

User Feedback ↑ TOP

**Step5** Download the NuMicro™ Keil μVision® IDE driver.

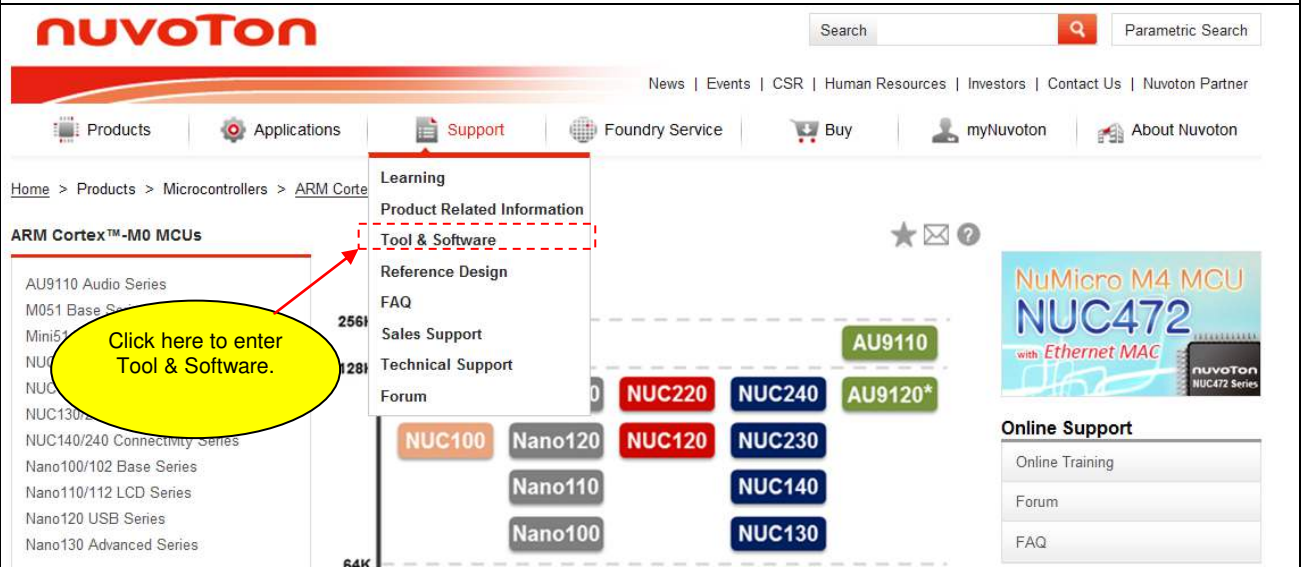

## 6.2 Downloading NuMicro™ IAR EWARM Driver



<p><b>Step1</b></p>	<p>Visit the Nuvoton NuMicro™ website: <a href="http://www.nuvoton.com/NuMicro">http://www.nuvoton.com/NuMicro</a>.</p>
<p><b>Step2</b></p>	 <p>The screenshot shows the Nuvoton website's navigation menu. The 'Support' menu is open, and 'Tool &amp; Software' is highlighted with a red dashed box. A yellow callout bubble with a red arrow points to this option, containing the text: "Click here to enter Tool &amp; Software."</p>
<p><b>Step3</b></p>	 <p>The screenshot shows the 'Development Tool Hardware' page on the Nuvoton website. The left sidebar menu has 'Software' highlighted with a red dashed box. A yellow callout bubble with a red arrow points to this option, containing the text: "Click here to enter Device Driver and Software Library."</p>

<b>Step4</b>	<i>Programmer Software Tools Package</i>																			
	<table border="1"> <thead> <tr> <th>File name</th> <th>Description</th> <th>Version</th> <th>Date</th> </tr> </thead> <tbody> <tr> <td>  ICP Programming Tool V1.25.6287.zip   Revision History                 </td> <td>NuMicro ICP tool &amp; user manual</td> <td>V1.25.6287</td> <td>2014-01-16</td> </tr> <tr> <td>  ISP Programming Tool V1.44.zip   Revision History                 </td> <td>NuMicro ISP Programming Tool &amp; user manual</td> <td>V1.44</td> <td>2014-01-20</td> </tr> <tr> <td>  NuGang Programmer V6.21.zip   Revision History                 </td> <td>NuGang Programmer software &amp; user manual</td> <td>V6.21</td> <td>2014-01-24</td> </tr> </tbody> </table>				File name	Description	Version	Date	ICP Programming Tool V1.25.6287.zip Revision History	NuMicro ICP tool & user manual	V1.25.6287	2014-01-16	ISP Programming Tool V1.44.zip Revision History	NuMicro ISP Programming Tool & user manual	V1.44	2014-01-20	NuGang Programmer V6.21.zip Revision History	NuGang Programmer software & user manual	V6.21	2014-01-24
	File name	Description	Version	Date																
	ICP Programming Tool V1.25.6287.zip Revision History	NuMicro ICP tool & user manual	V1.25.6287	2014-01-16																
ISP Programming Tool V1.44.zip Revision History	NuMicro ISP Programming Tool & user manual	V1.44	2014-01-20																	
NuGang Programmer V6.21.zip Revision History	NuGang Programmer software & user manual	V6.21	2014-01-24																	
<i>Nu-Link Driver</i>																				
<table border="1"> <thead> <tr> <th>File name</th> <th>Description</th> <th>Version</th> <th>Date</th> </tr> </thead> <tbody> <tr> <td>  Nu-Link Driver for Keil RVMDK V1.25.6287.zip   Revision History                 </td> <td>This driver is to support Nu-Link to work under Keil RVMDK Development Environment for all NuMicro Family Devices.</td> <td>V1.25.6287</td> <td>2014-01-16</td> </tr> <tr> <td>  Nu-Link Driver for IAR EWARM V1.25.6287.zip   Revision History                 </td> <td>This driver is to support Nu-Link to work under IAR EWARM Development Environment for all NuMicro Family Devices.</td> <td>V1.25.6287</td> <td>2014-01-16</td> </tr> </tbody> </table>				File name	Description	Version	Date	Nu-Link Driver for Keil RVMDK V1.25.6287.zip Revision History	This driver is to support Nu-Link to work under Keil RVMDK Development Environment for all NuMicro Family Devices.	V1.25.6287	2014-01-16	Nu-Link Driver for IAR EWARM V1.25.6287.zip Revision History	This driver is to support Nu-Link to work under IAR EWARM Development Environment for all NuMicro Family Devices.	V1.25.6287	2014-01-16					
File name	Description	Version	Date																	
Nu-Link Driver for Keil RVMDK V1.25.6287.zip Revision History	This driver is to support Nu-Link to work under Keil RVMDK Development Environment for all NuMicro Family Devices.	V1.25.6287	2014-01-16																	
Nu-Link Driver for IAR EWARM V1.25.6287.zip Revision History	This driver is to support Nu-Link to work under IAR EWARM Development Environment for all NuMicro Family Devices.	V1.25.6287	2014-01-16																	
<div style="text-align: right;">  User Feedback ↑ TOP                 </div>																				
<b>Step5</b>	Download the NuMicro™ IAR EWARM driver.																			

Click here to download the file.

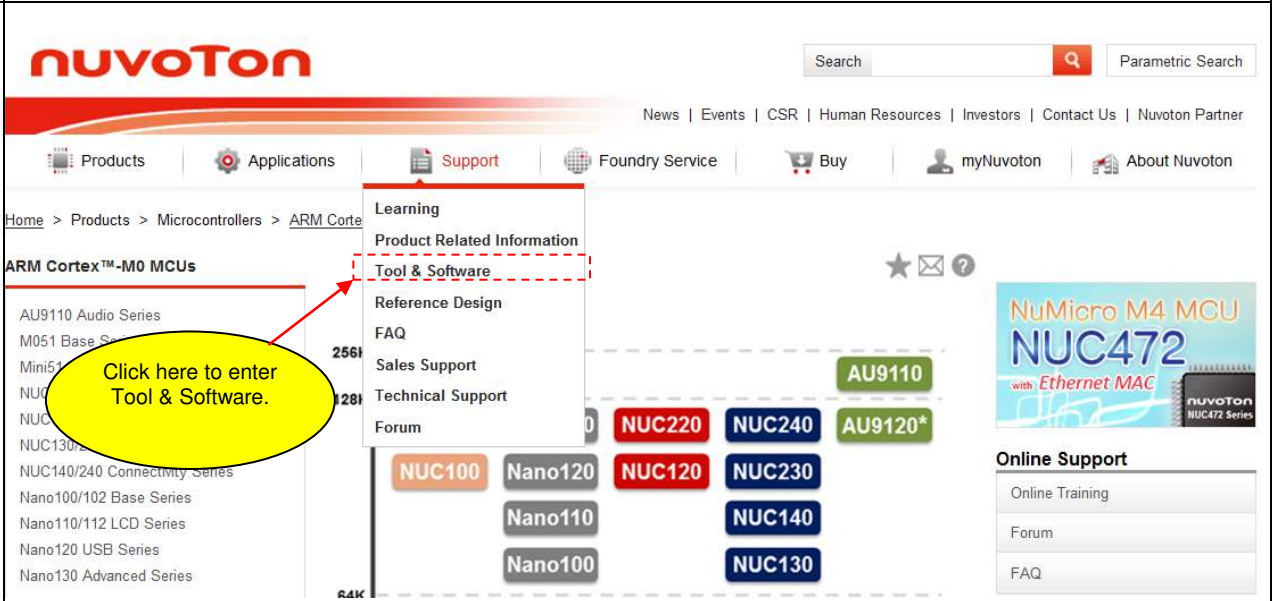

## 6.3 Downloading NuMicro™ NUC442 Series BSP Software Library

<p><b>Step1</b></p>	<p>Visit the Nuvoton NuMicro™ website: <a href="http://www.nuvoton.com/NuMicro">http://www.nuvoton.com/NuMicro</a>.</p>
<p><b>Step2</b></p>	
<p><b>Step3</b></p>	
<p><b>Step 3</b></p>	<p>Download the NuMicro™ NUC442 Series CMSIS BSP.</p>



## 7 Revision History

Revision	Date	Description
1.1	March 01, 2016	1. Corrected the MCU pin assignment. 2. Modified the schematic and added the USB Type-A connector.
1.0	May 09, 2014	Initial release

### Important Notice

Nuvoton Products are neither intended nor warranted for usage in systems or equipment, any malfunction or failure of which may cause loss of human life, bodily injury or severe property damage. Such applications are deemed, "Insecure Usage".

Insecure usage includes, but is not limited to: equipment for surgical implementation, atomic energy control instruments, airplane or spaceship instruments, the control or operation of dynamic, brake or safety systems designed for vehicular use, traffic signal instruments, all types of safety devices, and other applications intended to support or sustain life.

All Insecure Usage shall be made at customer's risk, and in the event that third parties lay claims to Nuvoton as a result of customer's Insecure Usage, customer shall indemnify the damages and liabilities thus incurred by Nuvoton.

---

Please note that all data and specifications are subject to change without notice.  
All the trademarks of products and companies mentioned in this datasheet belong to their respective owners.