

R/A JACK RECEPTACLE FOR PCB

**R114.665.000**

SOLDER LEGS

Series : SMB

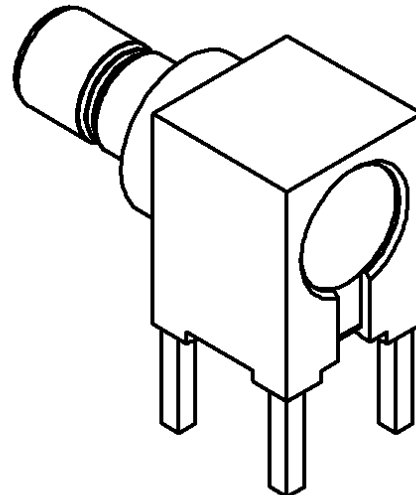
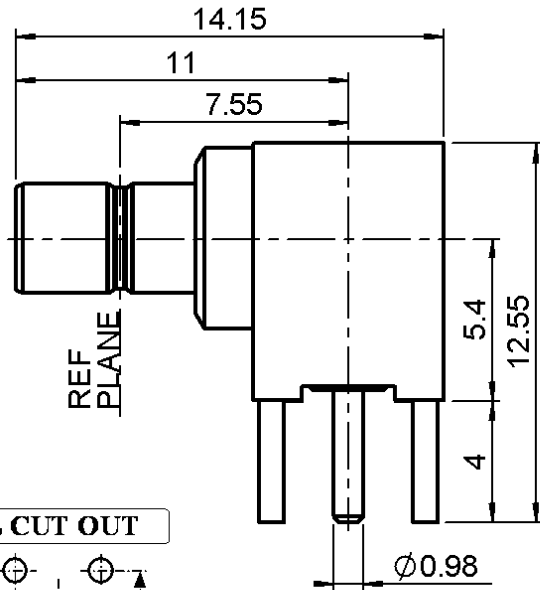
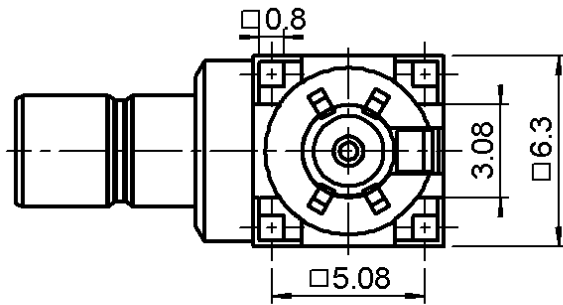

PANEL CUT OUT

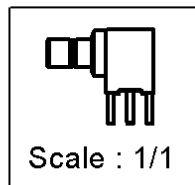
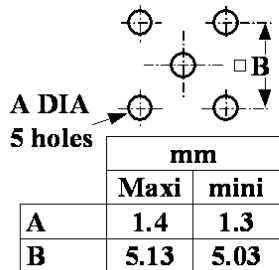

All dimensions are in mm.

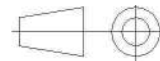

COMPONENTS	MATERIALS	PLATING (µm)
BODY	BRASS	GOLD 0.2 OVER NICKEL 2
CENTER CONTACT	BRASS	GOLD 1.3 OVER NICKEL2
OUTER CONTACT	-	-
INSULATOR	PTFE	-
GASKET	-	-
OTHERS PARTS	BRASS	GOLD 0.2 OVER NICKEL 2
-	-	-
-	-	-

Issue : 0706 C

In the effort to improve our products, we reserve the right to make changes judged to be necessary.



**R/A JACK RECEPTACLE FOR PCB**

**R114.665.000**

**SOLDER LEGS**

Series : SMB

**PACKAGING**

**SPECIFICATION**

Standard	Unit	Other
<b>100</b>	<b>'W' option</b>	<b>Contact us</b>

**QAE 06-02 - -**

**ELECTRICAL CHARACTERISTICS**

**ENVIRONMENTAL**

Impedance **50** Ω  
 Frequency **0-4** GHz  
 VSWR **1.20\*** + **0,0000** x F(GHz) Maxi  
 Insertion loss **0.25\*** √F(GHz) dB Maxi  
 RF leakage - ( **57** - F(GHz)) dB Maxi  
 Voltage rating **500** Veff Maxi  
 Dielectric withstanding voltage **1000** Veff mini  
 Insulation resistance **1000** MΩ mini

Operating temperature **-65/+165** ° C  
 Hermetic seal **NA** Atm.cm3/s  
 Panel leakage **NA**

**OTHER CHARACTERISTICS**

Assembly instruction **NA**

Others :  
 \* coaxial transmission line only

**MECHANICAL CHARACTERISTICS**

Center contact retention  
 Axial force – Mating end **10** N mini  
 Axial force – Opposite end **10** N mini  
 Torque **NA** N.cm mini

Recommended torque  
 Mating **NA** N.cm  
 Panel nut **NA** N.cm

Mating life **500** Cycles mini  
 Weight **2,8300** g

Issue : 0706 C

In the effort to improve our products, we reserve the right to make changes judged to be necessary.

