

PART NO.	ENG NO.	PLATING
008-56-0113	2477-G	565
008-56-0114	2477-GL	565
008-50-0109	2477-(P909)	P909
008-50-0110	2477-(P909)L	P909

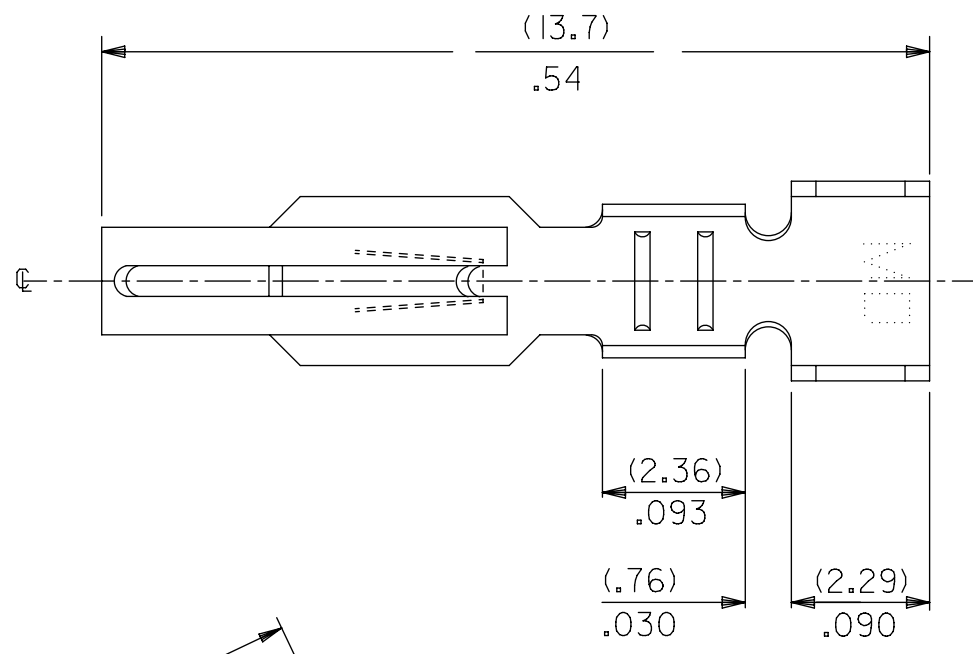

2477- \* \* - \* - \*

MATERIAL CODE  
(.25)/.010 THK  
BLANK= BRASS

WINDING SPEC.  
BLANK=CHAIN, PER WINDING DETAIL "B"  
L=LOOSE

OPTION CODE  
BLANK=AS SHOWN

PLATING  
SEE NOTE 2

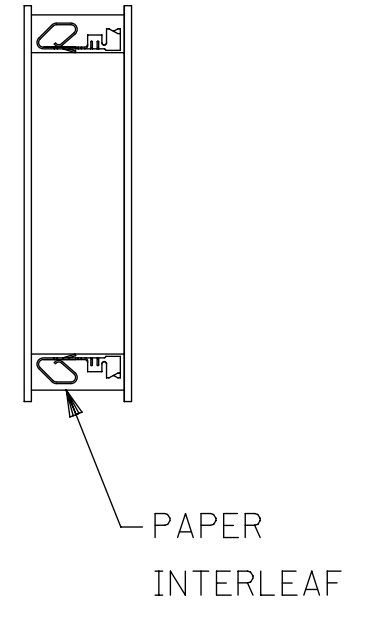
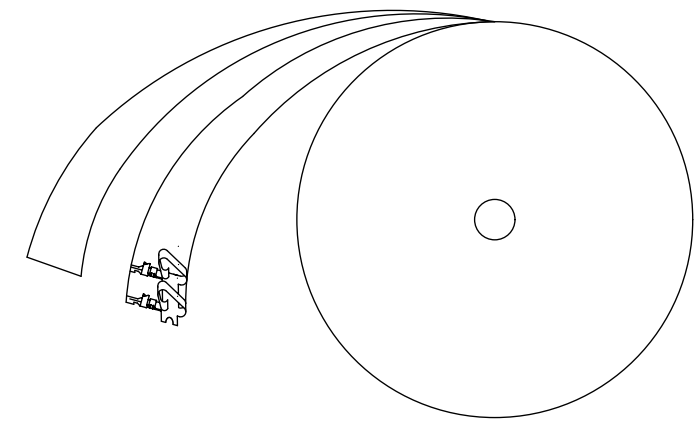
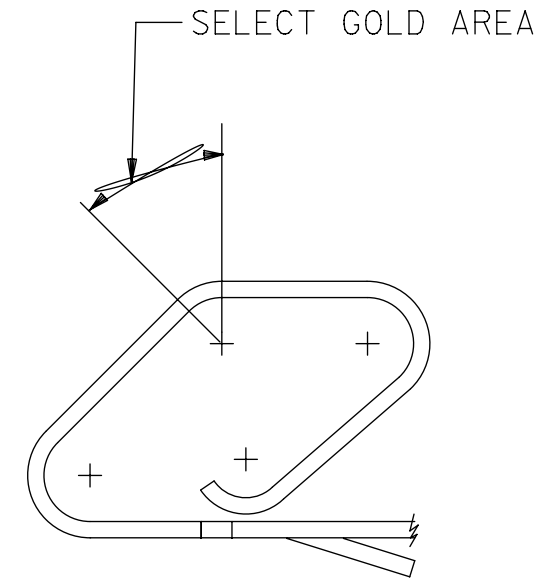
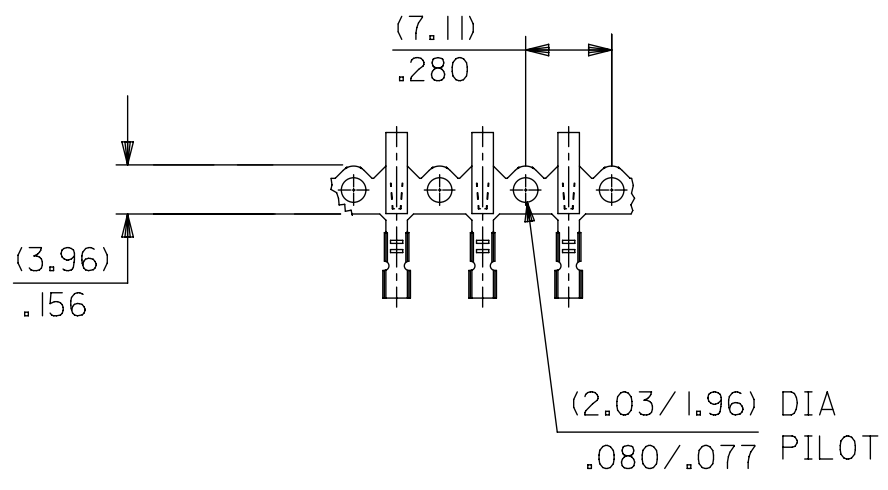
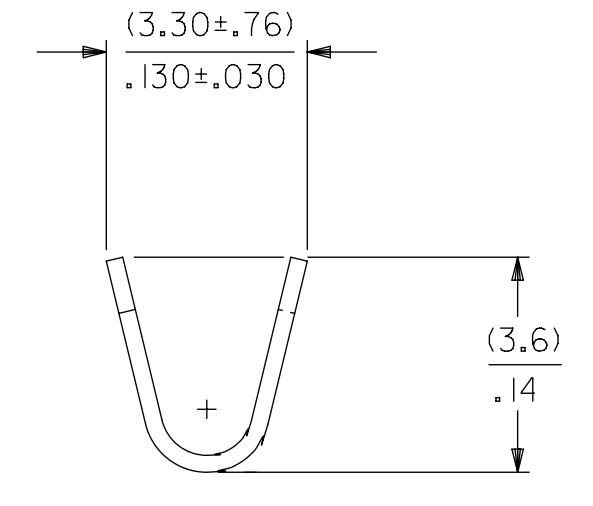
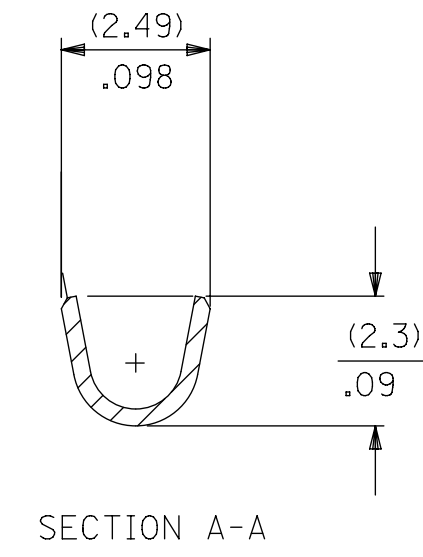
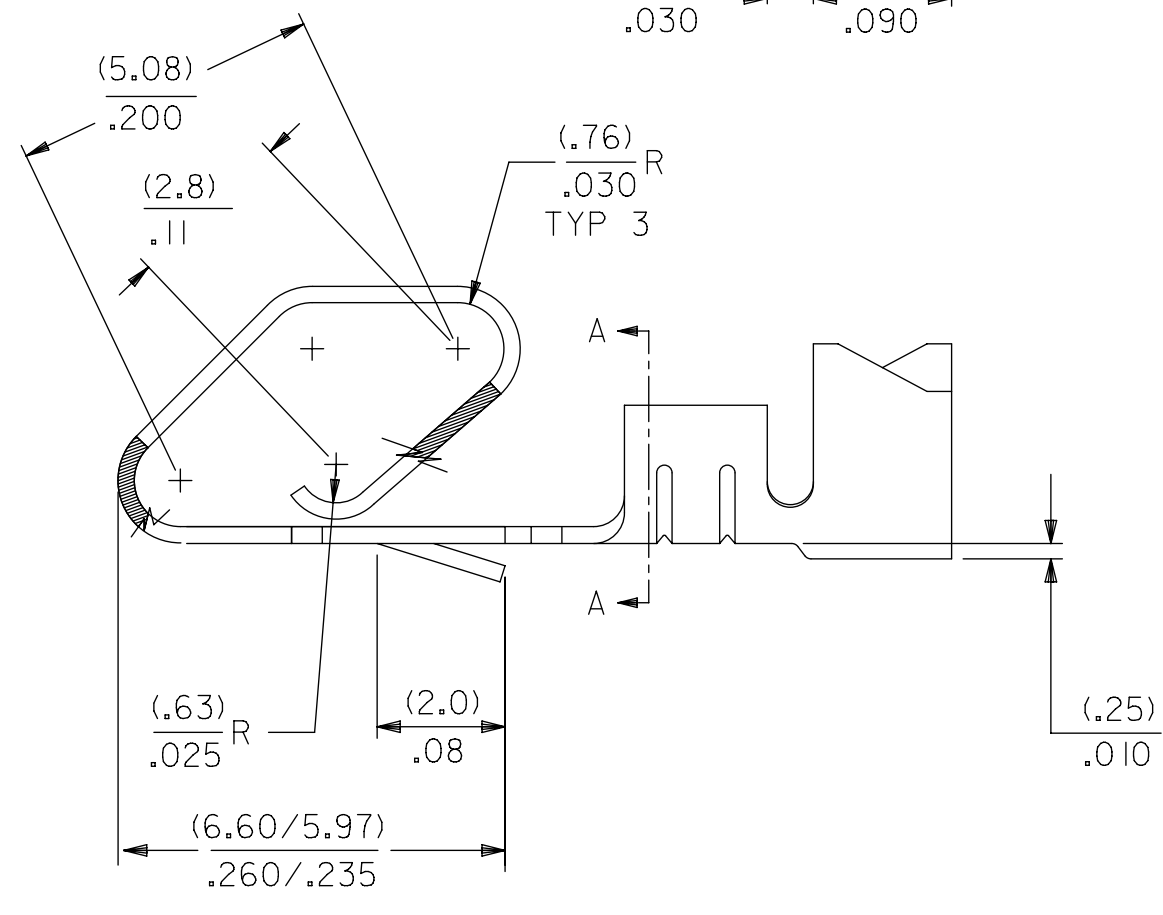
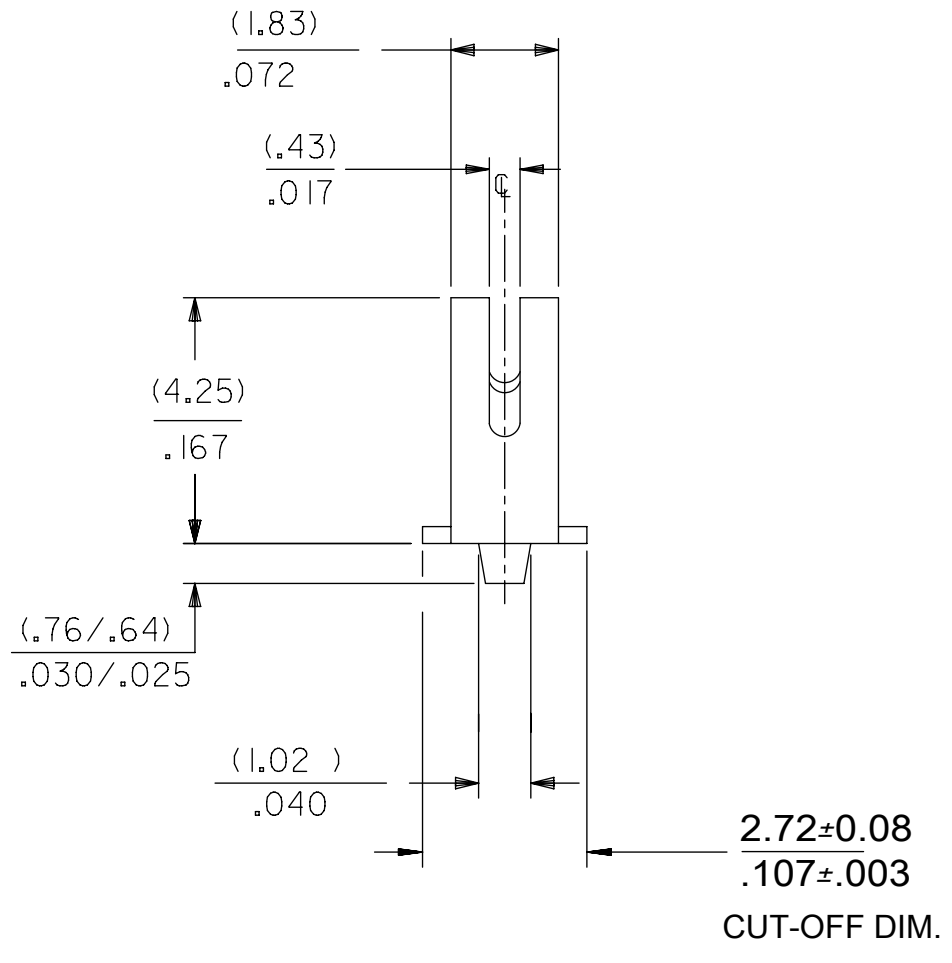

- NOTES:
- MATERIAL: SEE LEGEND
  - FINISH: P909: OVERALL HOT TIN DIP: (0.00254)/.000100 MIN.  
565: SELECT GOLD: (0.00051)/.000020 MIN.  
OVERALL NICKEL: (0.00076)/.000030 MIN.  
OVERALL GOLD FLASH: (0.00005)/.000002 MIN.
  - PRODUCT SPECIFICATION: PS-08-50
  - PACKAGING SPECIFICATION: LOOSE TERMINALS: PK-2759-001  
CHAIN FORM TERMINALS: PER PK-2759-002
  - CRIMP ACCEPTS 18 TO 24 GA. WIRE WITH (2.79)/.110 MAX. INSULATION DIA.
  - TERMINAL FOR USE IN 2139 AND 3069 SERIES HOUSINGS WITH (2.54)/.100 MAX. INSULATION DIAMETER AND 172159 SERIES HOUSINGS WITH (2.79)/.110 MAX. INSULATION DIAMETER.
  - THIS PART CONFORMS TO CLASS B REQUIREMENTS OF COSMETIC SPECIFICATION PS-45499-002.
  - MATING TERMINALS TO ROUND PINS IS NOT RECOMMENDED.

THIS DRAWING CONTAINS INFORMATION THAT IS PROPRIETARY TO MOLEX ELECTRONIC TECHNOLOGIES, LLC AND SHOULD NOT BE USED WITHOUT WRITTEN PERMISSION									
SYMBOLS		DIMENSION UNITS		SCALE		CURRENT REV DESC: NOTE 4 ADDED			
▽ = 0	MM/IN	1:1							
▽ = 0	GENERAL TOLERANCES (UNLESS SPECIFIED)								
▽ = 0		MM	INCH						
▽ = 0	4 PLACES	±	±	EC NO: 605479					
▽ = 0	3 PLACES	±	± 0.01	DRWN: SS06 2018/09/19					
▽ = 0	2 PLACES	± 0.25	± 0.014	CHK'D: ISHWARG 2018/10/05					
▽ = 0	1 PLACE	± 0.36	±	APPR: ISHWARG 2018/10/05					
▽ = 0	0 PLACES	±	±	INITIAL REVISION:					
▽ = 0	ANGULAR TOL	± 0.5 °	DRWN: SAMIEC 1995/03/02						
▽ = 0	DRAFT WHERE APPLICABLE MUST REMAIN WITHIN DIMENSIONS		THIRD ANGLE PROJECTION		DRAWING		SERIES		
▽ = 0			C-SIZE		2477		MATERIAL NUMBER		
				SEE CHART		CUSTOMER		SHEET NUMBER	
				GENERAL MARKET		1 OF 1			

DOCUMENT STATUS	P1	RELEASE DATE	2018/10/05 09:56:19
-----------------	----	--------------	---------------------