

THIS DOCUMENT IS THE PROPERTY OF
KEYSTONE ELECTRONICS CORP. AND
SHALL NOT BE REPRODUCED, DISTRIBUTED
OR USED AS A BASIS FOR MANUFACTURE
WITHOUT PRIOR WRITTEN PERMISSION
FROM KEYSTONE ELECTRONICS CORP.

ACTUAL SIZE

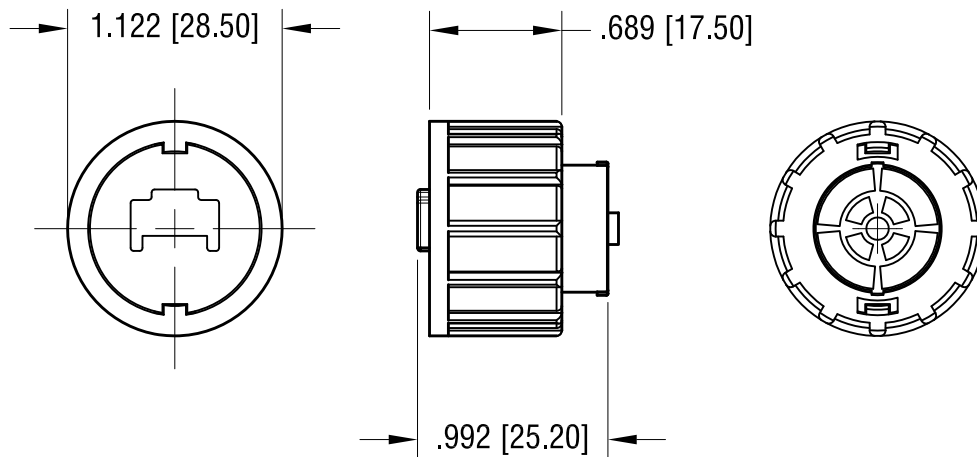
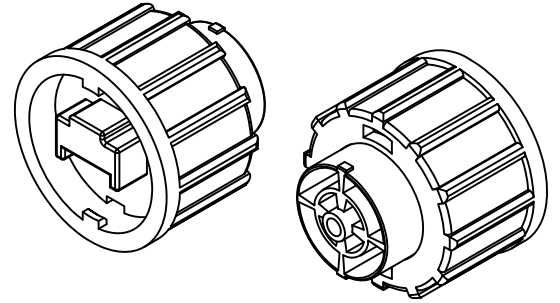

7.21.16 REVISED WATER TIGHT SEAL
CHANGE AS PER ECN 16-075

A
REV.

KEYSTONE ELECTRONICS CORP.			
www.keyelco.com • ASTORIA, N.Y. 11105-2017 • Tel (718) 956-8900			
PART NAME			
WATER PROOF KEYSTONE CAP			
MATERIAL			
THERMOPLASTIC, UL 94V-0 (BLACK COLOR)			
FINISH		DRN BY	DATE
-		NT	4.04.16
		APP'D	SCALE
		LN	1X
TOLERANCES	INCH [MM]	CODE	DWG NO.
DECIMAL	± .005 [± 0.13]	C	963C
ANGULAR	± 1°		
UNLESS OTHERWISE SPECIFIED			