

This document is the property of Amphenol Corporation and is delivered on the express condition that is not to be disclosed, reproduced or used, in whole or in part, for manufacture or sale by anyone other than Amphenol Corporation without its prior consent, and that no right is granted to disclose or to use any information in this document.

The marking on this product doesn't contain environmental hazardous material and must follow one or more specifications per Material Specification SS-00259 for Sony GP compliant or per directive EU/2015/863 for RoHS compliant or per IEC 61249-2-21 for Halogen Free compliant.

ORIGINAL

PART NUMBER:
GSB3 112 X X X HR

CONTACT FINISH: 3: 30μ" GOLD
SOLDER TAIL LENGTH / PACKING

| PART NO | DIM. E | DIM. F | PACKING |
|---------|--------|--------|---------|
| "BLANK" | 2.4 | 3.0 | TRAY |
| "1" | 3.0 | 3.5 | TRAY |
| "A" | 2.4 | 3.0 | T&R |
| "B" | 3.0 | 3.5 | T&R |

INSULATOR AND COLOR
1: LCP, Blue
3: LCP, Black



| REVISIONS | | | | |
|-----------|----------|---|------------|-------------|
| SYM | ECN No. | DESCRIPTION | DATE | BY |
| A | | RELEASE TO PRODUCTION | 07/02/2010 | Sondra Sang |
| B | NE-10119 | MODIFIED THE FRONT SHELL PLATING | 07/28/2010 | Sondra Sang |
| C | NE-10123 | MODIFIED PINS | 08/06/2010 | Sondra Sang |
| D | NE-10161 | MODIFIED MATERIAL | 10/06/2010 | Sondra Sang |
| E | NE-11083 | ADDED PANEL CUTOUT | 06/23/2011 | Sondra Sang |
| F | NE-14014 | MODIFIED PINS ADDED OPTIONS | 01/22/2014 | Sondra Sang |
| A1 | NE-15033 | ADD SHRAPNEL HEIGHT DIM | 08/11/2015 | Arron Lin |
| B1 | NE-16280 | ADDED D/C PK | 12/06/2016 | Arron Lin |
| C1 | NE-17112 | REMOVE 2u" GOLD+30u" Pd-Ni AND NYLON OPTION | 05/24/2017 | Arron Lin |
| D1 | NE-17157 | ADD T&R OPTION | 08/16/2017 | Arron Lin |

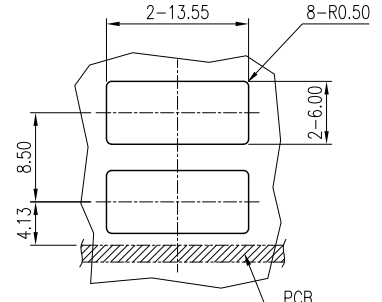
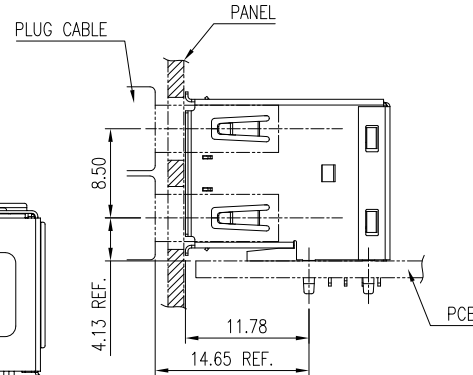
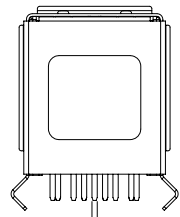
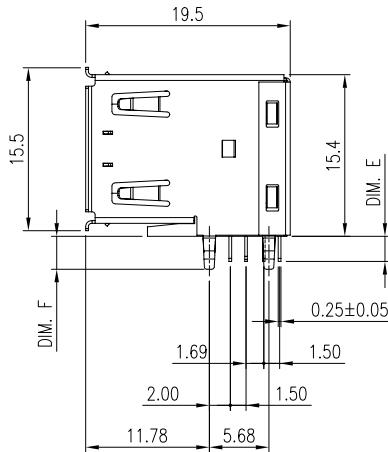
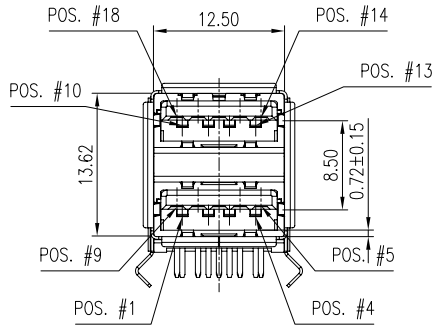
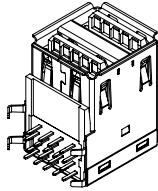
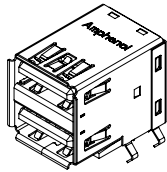
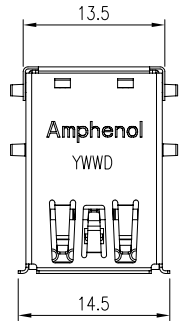

RECOMMEND MOUNTING CONFIGURATION

RECOMMEND PANEL CUTOUT

NOTES:

- HOUSING: HIGH TEMPERATURE THERMOPLASTIC, UL 94V-0, COLOR- BLUE (PANTONE 300C) OR BLACK
- BOTTOM COVER: HIGH TEMPERATURE THERMOPLASTIC, UL 94V-0, COLOR- BLUE (PANTONE 300C) OR BLACK
- CONTACT: COPPER ALLOY, 0.25mm THICKNESS, 30μ" MIN. GOLD PLATED ON CONTACT AREA, 120μ" MIN. MATTE TIN PLATED ON SOLDERING TAIL, 80μ" MIN. NICKEL UNDER-PLATED OVERALL
- FRONT SHELL: STAINLESS STEEL, 0.25mm THICKNESS, 30μ" MIN. NICKEL PLATED OVER ALL
- MIDDLE SHELL: STAINLESS STEEL, 0.25mm THICKNESS,
- REAR SHELL: STAINLESS STEEL, 0.2mm THICKNESS,
- THIS PRODUCT DOESN'T CONTAIN ENVIRONMENTAL HAZARDOUS MATERIALS PER DIRECTIVE EU/2015/863 FOR RoHS AND PER IEC 61249-2-21 FOR HALOGEN FREE COMPLIANT.

| PIN # | PIN # | SIGNAL NAME |
|-------|-------|-------------|
| 1 | 10 | VBUS |
| 2 | 11 | D- |
| 3 | 12 | D+ |
| 4 | 13 | GND |
| 5 | 14 | SSRX- |
| 6 | 15 | SSRX+ |
| 7 | 16 | GND_DRAIN |
| 8 | 17 | SSTX- |
| 9 | 18 | SSTX+ |
| SHELL | | SHIELD |

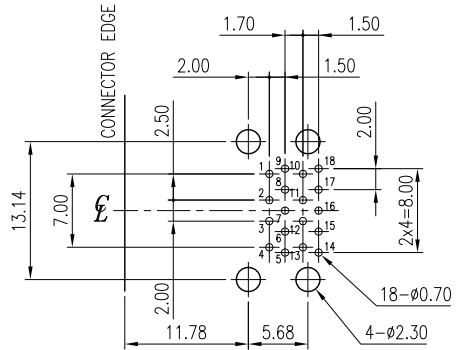

RECOMMENDED PCB LAYOUT- TOP VIEW (GENERAL TOLERANCE: ±0.05)

PIN ASSIGNMENT

| TOLERANCE | APPROVALS | DATE | TITLE | UNIT | SIZE | PART No. | |
|----------------------------|------------|--------------|---|-------|--------|-----------------|-----------|
| X. | DRAWN | 08/16/2017 | USB 3.0 CONNECTOR STANDARD A, STACKED, R/A DIP TYPE | mm | A3 | GSB3 112 XX XHR | |
| X.X ±0.30 | Debby Hung | 08/16/2017 | | | | | |
| X.XX ±0.20 | CHECKED | 08/16/2017 | | | | | Sandy Wu |
| X.XXX ±0.10 | APPROVED | 08/16/2017 | | | | | Arron Lin |
| ANGULAR ±1° | DWG TYPE | PROJECT CODE | UNIT | SCALE | SHEET | DWG No. | |
| UNLESS OTHERWISE SPECIFIED | CUST DWG | OTHER | mm | NA | 1 OF 3 | GSB311231HR | |

Amphenol®

Amphenol Corporation
Amphenol Taiwan Corporation

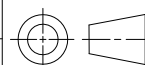

REV. D1

This document is the property of Amphenol Corporation and is delivered on the express condition that is not to be disclosed, reproduced or used, in whole or in part, for manufacture or sale by anyone other than Amphenol Corporation without its prior consent, and that no right is granted to disclose or to use any information in this document.

The marking on this product doesn't contain environmental hazardous material and must follow one or more specifications per Material Specification SS-00259 for Sony GP compliant or per directive EU/2015/863 for RoHS compliant or per IEC 61249-2-21 for Halogen Free compliant.



ORIGINAL



| REVISIONS | | | | |
|-----------|----------|---|------------|-------------|
| SYM | ECN No. | DESCRIPTION | DATE | BY |
| A | | RELEASE TO PRODUCTION | 07/02/2010 | Sondra Sang |
| B | NE-10119 | MODIFIED THE FRONT SHELL PLATING | 07/28/2010 | Sondra Sang |
| C | NE-10123 | MODIFIED PINS | 08/06/2010 | Sondra Sang |
| D | NE-10161 | MODIFIED MATERIAL | 10/06/2010 | Sondra Sang |
| E | NE-11083 | ADDED PANEL CUTOUT | 06/23/2011 | Sondra Sang |
| F | NE-14014 | MODIFIED PINS ADDED OPTIONS | 01/22/2014 | Sondra Sang |
| A1 | NE-15033 | ADD SHRAPNEL HEIGHT DIM | 08/11/2015 | Arron Lin |
| B1 | NE-16280 | ADDED D/C PK | 12/06/2016 | Arron Lin |
| C1 | NE-17112 | REMOVE 2u" GOLD+30u" Pd-Ni AND NYLON OPTION | 05/24/2017 | Arron Lin |
| D1 | NE-17157 | ADD T&R OPTION | 08/16/2017 | Arron Lin |

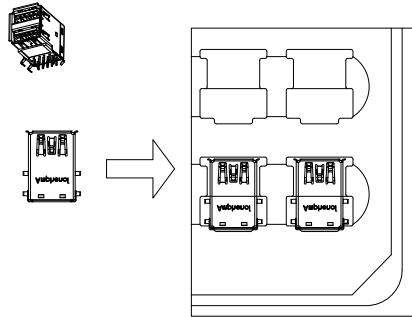
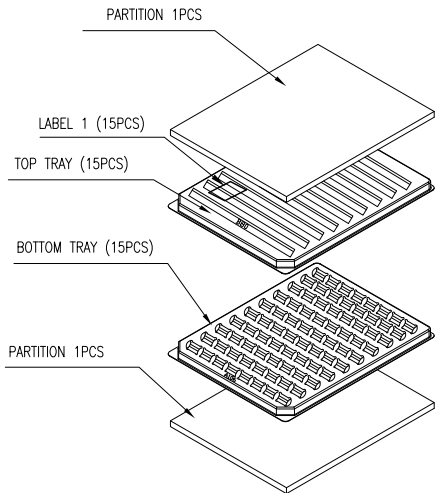

| | |
|---|---|
| P/N : GSBX11231HR GSB311231HR | LABEL 1 = QTY : 100 LABEL 2 = QTY : 1500 |
| QTY : 100 100 | |
| P/O : 411-012345-001 411-012345-001 | |
| DATE : 04 / 01 / 2010 MM / DD / YYYY | |
| G.W : 15.00 KG | RoHS |
| Amphenol Taiwan Corporation | |

LABEL 1 & LABEL 2

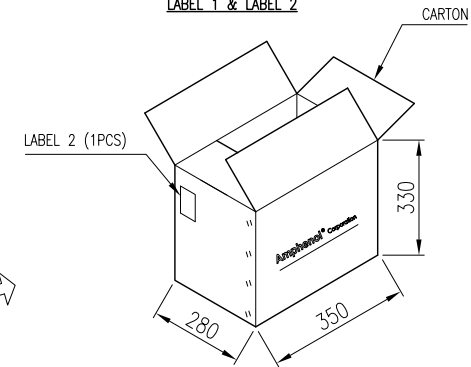
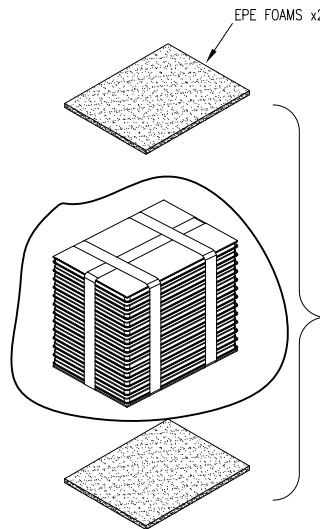
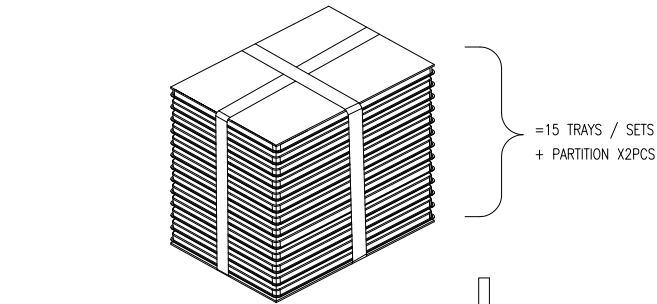

- NOTES:
1. MATERIAL: TRAY- PET
 2. THICKNESS: 0.80 mm MINIMUM
 3. THE BARCODE MUST BE 3 OF 9 BARCODE
 4. COMPONENTS LOAD PER THE TRAY: 100 PCS.
 5. THIS PRODUCT DOESN'T CONTAIN ENVIRONMENTAL HAZARDOUS MATERIALS PER DIRECTIVE 2011/65/EC FOR RoHS COMPLIANT

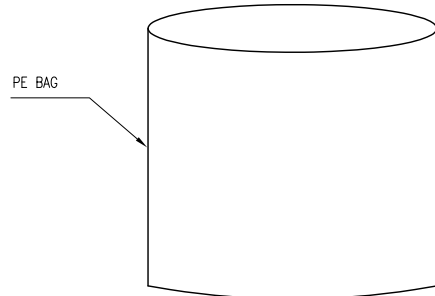

| PART NO. | PCS. / TRAY | TRAY / CARTCON | N.W. | G.W. |
|--------------|-------------|------------------|------|------|
| GSBX112XXXHR | 100 PCS. | 100X15=1500 PCS. | * | * Kg |

(***) FOR REFERENCE

| TOLERANCE | APPROVALS | DATE | TITLE | UNIT | SIZE | PART No. |
|--|--------------------|--------------------|---|----------|--------------|---------------------|
| X. ±0.30 X.X ±0.20 X.XX ±0.10 X.XXX ±0.10 | DRAWN Debby Hung | 08/16/2017 | USB 3.0 CONNECTOR STANDARD A, STACKED, R/A DIP TYPE | mm | A3 | GSB3 112 XX XHR |
| ANGULAR ±1° | CHECKED Sandy Wu | 08/16/2017 | | SCALE NA | SHEET 2 OF 3 | |
| UNLESS OTHERWISE SPECIFIED | APPROVED Arron Lin | 08/16/2017 | | | | DWG No. GSB311231HR |
| | DWG TYPE CUST DWG | PROJECT CODE OTHER | | | | REV. D1 |

Amphenol®

Amphenol Corporation
Amphenol Taiwan Corporation

This document is the property of Amphenol Corporation and is delivered on the express condition that is not to be disclosed, reproduced or used, in whole or in part, for manufacture or sale by anyone other than Amphenol Corporation without its prior consent, and that no right is granted to disclose or to use any information in this document.

The marking on this product doesn't contain environmental hazardous material and must follow one or more specifications per Material Specification SS-00259 for Sony GP compliant or per directive EU/2015/863 for RoHS compliant or per IEC 61249-2-21 for Halogen Free compliant.



ORIGINAL



| REVISIONS | | | | |
|-----------|----------|---|------------|-------------|
| SYM | ECN No. | DESCRIPTION | DATE | BY |
| A | | RELEASE TO PRODUCTION | 07/02/2010 | Sondra Sang |
| B | NE-10119 | MODIFIED THE FRONT SHELL PLATING | 07/28/2010 | Sondra Sang |
| C | NE-10123 | MODIFIED PINS | 08/06/2010 | Sondra Sang |
| D | NE-10161 | MODIFIED MATERIAL | 10/06/2010 | Sondra Sang |
| E | NE-11083 | ADDED PANEL CUTOUT | 06/23/2011 | Sondra Sang |
| F | NE-14014 | MODIFIED PINS ADDED OPTIONS | 01/22/2014 | Sondra Sang |
| A1 | NE-15033 | ADD SHRAPNEL HEIGHT DIM | 08/11/2015 | Arron Lin |
| B1 | NE-16280 | ADDED D/C PK | 12/06/2016 | Arron Lin |
| C1 | NE-17112 | REMOVE 2u" GOLD+30u" Pd-Ni AND NYLON OPTION | 05/24/2017 | Arron Lin |
| D1 | NE-17157 | ADD T&R OPTION | 08/16/2017 | Arron Lin |

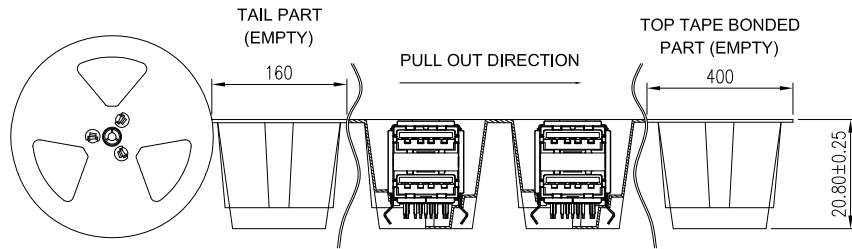
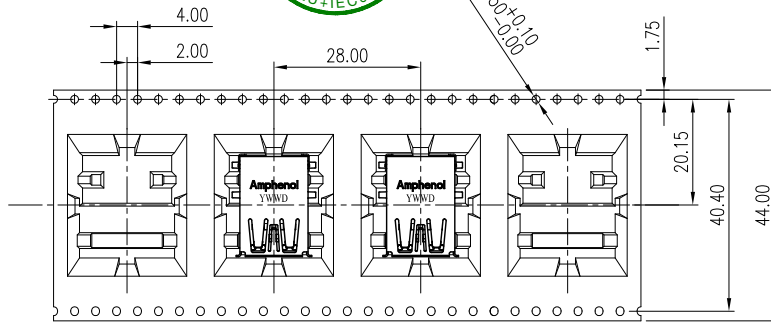

| REEL SIZE | PARTS PER CARTON<S.P.Q> | PARTS PER REEL | TOTEL REEL PER CARTON |
|-----------|-------------------------|----------------|-----------------------|
| ø330 | 1200 | 100 | 12 |

NOTES:

1. STAPLES SHOULD ONLY BE USED TO SET UP CARTON. ALL CARTON CLOSURES MUST BE DONE WITH TAPE.
2. FILL PACKAGING TRAYS WITH THE QUANTITIES AS INDICATED IN THE CHART.
3. SHIPPING CARTON DIMENSION: 690 X 360 X 325mm.
4. NET WEIGHT: 6.74 KG. GROSS WEIGHT: 13.34 KG.

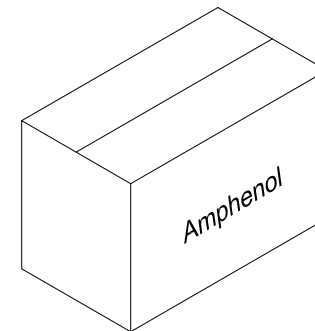
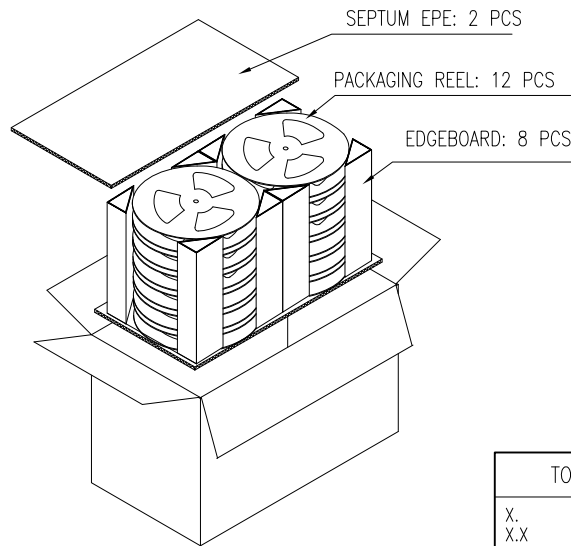

| TOLERANCE | | APPROVALS | | DATE | TITLE | | | | | | | | |
|----------------------------|-------|-----------|------------|--------------|---|---|----|-------|--------|----------|-----------------|------|----|
| X. | | DRAWN | Debby Hung | 08/16/2017 | USB 3.0 CONNECTOR STANDARD A, STACKED, R/A DIP TYPE | Amphenol Corporation Amphenol Taiwan Corporation | | | | | | | |
| X.X | ±0.30 | CHECKED | Sandy Wu | 08/16/2017 | | | | | | | | | |
| X.XX | ±0.20 | APPROVED | Arron Lin | 08/16/2017 | | | | | | | | | |
| X.XXX | ±0.10 | DWG TYPE | CUST DWG | PROJECT CODE | | | | | | OTHER | | | |
| ANGULAR | ±1° | | | | | UNIT | mm | SIZE | A3 | PART No. | GSB3 112 XX XHR | | |
| UNLESS OTHERWISE SPECIFIED | | | | | | SCALE | NA | SHEET | 3 OF 3 | DWG No. | GSB311231HR | REV. | D1 |