

74HC123-Q100; 74HCT123-Q100

Dual retriggerable monostable multivibrator with reset

Rev. 1 — 1 August 2012

Product data sheet

1. General description

The 74HC123-Q100; 74HCT123-Q100 are high-speed Si-gate CMOS devices and are pin compatible with Low-power Schottky TTL (LSTTL). They are specified in compliance with JEDEC standard no. 7A.

The 74HC123-Q100; 74HCT123-Q100 are dual retriggerable monostable multivibrators with output pulse width control by three methods:

1. The basic pulse is defined by the selection of the external resistor (R_{EXT}) and capacitor (C_{EXT}).
2. Once triggered, the basic output pulse width may be extended by retriggering the gated active LOW-going edge input ($n\bar{A}$) or the active HIGH-going edge input (nB). By repeating this process, the output pulse period ($nQ = \text{HIGH}$, $n\bar{Q} = \text{LOW}$) can be made as long as desired. Alternatively an output delay can be terminated at any time by a LOW-going edge on input $n\bar{RD}$, which also inhibits the triggering.
3. An internal connection from $n\bar{RD}$ to the input gates makes it possible to trigger the circuit by a HIGH-going signal at input $n\bar{RD}$ as shown in [Table 3](#).

Schmitt trigger action in the $n\bar{A}$ and nB inputs, makes the circuit highly tolerant to slower input rise and fall times.

This product has been qualified to the Automotive Electronics Council (AEC) standard Q100 (Grade 1) and is suitable for use in automotive applications.

2. Features and benefits

- Automotive product qualification in accordance with AEC-Q100 (Grade 1)
 - ◆ Specified from $-40\text{ }^{\circ}\text{C}$ to $+85\text{ }^{\circ}\text{C}$ and from $-40\text{ }^{\circ}\text{C}$ to $+125\text{ }^{\circ}\text{C}$
- DC triggered from active HIGH or active LOW inputs
- Retriggerable for very long pulses up to 100 % duty factor
- Direct reset terminates output pulse
- Schmitt trigger action on all inputs except for the reset input
- ESD protection:
 - ◆ MIL-STD-883, method 3015 exceeds 2000 V
 - ◆ HBM JESD22-A114F exceeds 2000 V
 - ◆ MM JESD22-A115-A exceeds 200 V ($C = 200\text{ pf}$, $R = 0\text{ }\Omega$)
- Specified from $-40\text{ }^{\circ}\text{C}$ to $+85\text{ }^{\circ}\text{C}$ and from $-40\text{ }^{\circ}\text{C}$ to $+125\text{ }^{\circ}\text{C}$



3. Ordering information

Table 1. Ordering information

Type number	Package			Version
	Temperature range	Name	Description	
74HC123D-Q100 74HCT123D-Q100	-40 °C to +125 °C	SO16	plastic small outline package; 16 leads; body width 3.9 mm	SOT109-1
74HC123PW-Q100 74HCT123PW-Q100	-40 °C to +125 °C	TSSOP16	plastic thin shrink small outline package; 16 leads; body width 4.4 mm	SOT403-1
74HC123BQ-Q100	-40 °C to +125 °C	DHVQFN16	plastic dual in-line compatible thermal enhanced very thin quad flat package; no leads; 16 terminals; body 2.5 × 3.5 × 0.85 mm	SOT763-1

4. Functional diagram

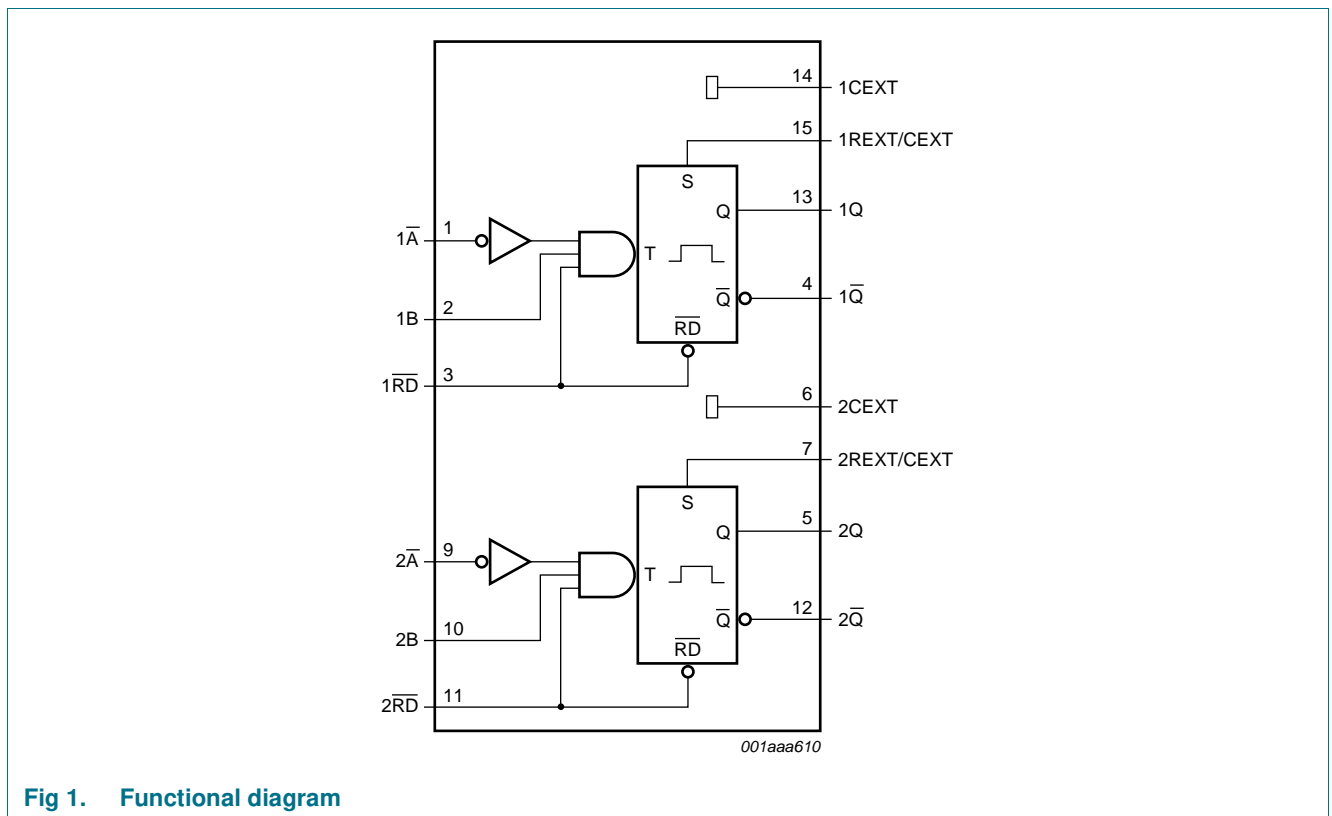

Fig 1. Functional diagram

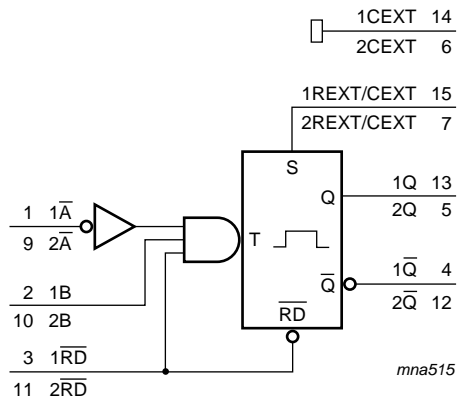

Fig 2. Logic symbol

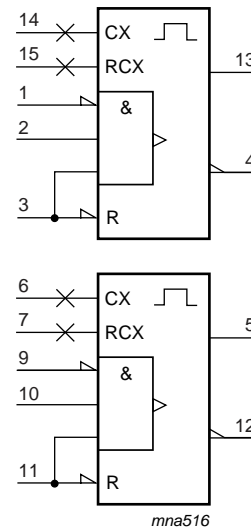

Fig 3. IEC logic symbol

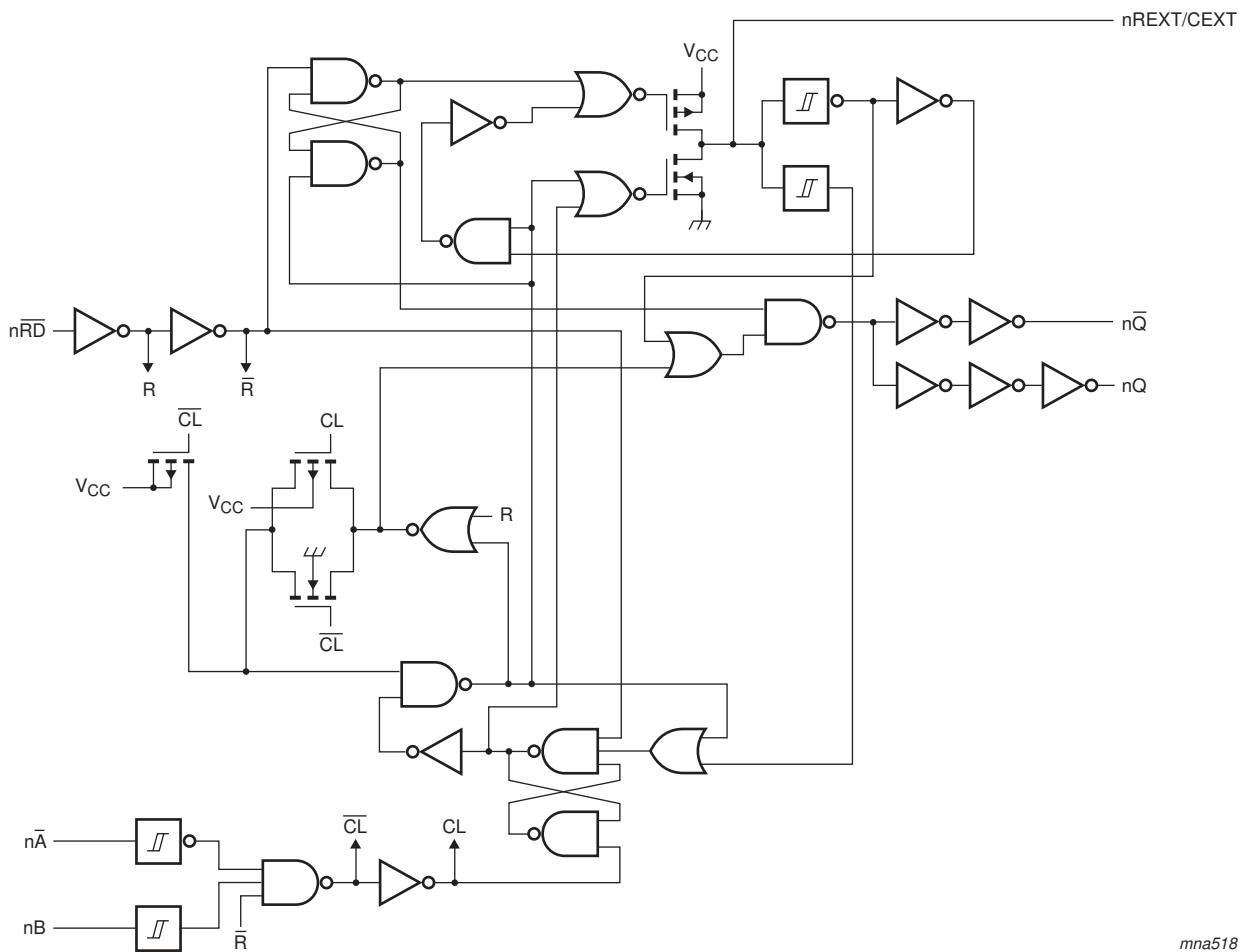
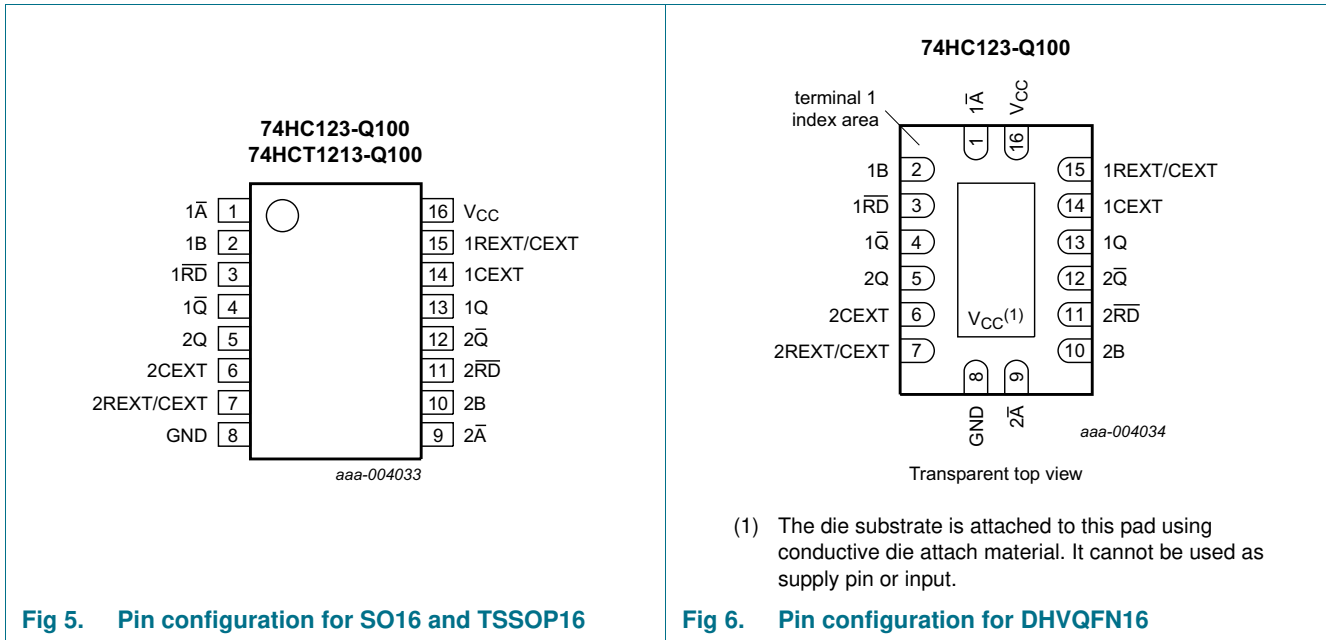

Fig 4. Logic diagram

5. Pinning information

5.1 Pinning









5.2 Pin description

Table 2. Pin description



Symbol	Pin	Description
1 \bar{A}	1	negative-edge triggered input 1
1B	2	positive-edge triggered input 1
1 \bar{RD}	3	direct reset LOW and positive-edge triggered input 1
1 \bar{Q}	4	active LOW output 1
2Q	5	active HIGH output 2
2CEXT	6	external capacitor connection 2
2REXT/CEXT	7	external resistor and capacitor connection 2
GND	8	ground (0 V)
2 \bar{A}	9	negative-edge triggered input 2
2B	10	positive-edge triggered input 2
2 \bar{RD}	11	direct reset LOW and positive-edge triggered input 2
2 \bar{Q}	12	active LOW output 2
1Q	13	active HIGH output 1
1CEXT	14	external capacitor connection 1
1REXT/CEXT	15	external resistor and capacitor connection 1
V _{CC}	16	supply voltage

6. Functional description

Table 3. Function table^[1]

Input			Output	
nRD	nA	nB	nQ	nQ
L	X	X	L	H
X	H	X	L ^[2]	H ^[2]
X	X	L	L ^[2]	H ^[2]
H	L	↑		
H	↓	H		
↑	L	H		

[1] H = HIGH voltage level; L = LOW voltage level; X = don't care; ↑ = LOW-to-HIGH transition; ↓ = HIGH-to-LOW transition;

 = one HIGH level output pulse;  = one LOW level output pulse.

[2] If the monostable was triggered before this condition was established, the pulse continues as programmed.

7. Limiting values

Table 4. Limiting values

In accordance with the Absolute Maximum Rating System (IEC 60134). Voltages are referenced to GND (ground = 0 V).

Symbol	Parameter	Conditions	Min	Max	Unit
V _{CC}	supply voltage		-0.5	+7	V
I _{IK}	input clamping current	V _I < -0.5 V or V _I > V _{CC} + 0.5 V	-	±20	mA
I _{OK}	output clamping current	V _O < -0.5 V or V _O > V _{CC} + 0.5 V	-	±20	mA
I _O	output current	except for pins nREXT/CEXT; V _O = -0.5 V to (V _{CC} + 0.5 V)	-	±25	mA
I _{CC}	supply current		-	50	mA
I _{GND}	ground current		-	-50	mA
T _{stg}	storage temperature		-65	+150	°C
P _{tot}	total power dissipation				
	SO16 package		^[3] -	500	mW
	TSSOP16 package		^[4] -	500	mW
	DHVQFN16 package		^[5] -	500	mW

[3] For SO16 packages: P_{tot} derates linearly with 8 mW/K above 70 °C.

[4] For TSSOP16 packages: P_{tot} derates linearly with 5.5 mW/K above 60 °C.

[5] For DHVQFN16 packages: P_{tot} derates linearly with 4.5 mW/K above 60 °C.

8. Recommended operating conditions

Table 5. Recommended operating conditions

Symbol	Parameter	Conditions	74HC123-Q100			74HCT123-Q100			Unit
			Min	Typ	Max	Min	Typ	Max	
V _{CC}	supply voltage		2.0	5.0	6.0	4.5	5.0	5.5	V
V _I	input voltage		0	-	V _{CC}	0	-	V _{CC}	V
V _O	output voltage		0	-	V _{CC}	0	-	V _{CC}	V
Δt/ΔV	input transition rise and fall rate	nRD input							
		V _{CC} = 2.0 V	-	-	625	-	-	-	ns/V
		V _{CC} = 4.5 V	-	1.67	139	-	1.67	139	ns/V
		V _{CC} = 6.0 V	-	-	83	-	-	-	ns/V
T _{amb}	ambient temperature		-40	+25	+125	-40	+25	+125	°C

9. Static characteristics

Table 6. Static characteristics

At recommended operating conditions; voltages are referenced to GND (ground = 0 V).

Symbol	Parameter	Conditions	25 °C			-40 °C to +85 °C		-40 °C to +125 °C		Unit
			Min	Typ	Max	Min	Max	Min	Max	
74HC123-Q100										
V _{IH}	HIGH-level input voltage	V _{CC} = 2.0 V	1.5	1.2	-	1.5	-	1.5	-	V
		V _{CC} = 4.5 V	3.15	2.4	-	3.15	-	3.15	-	V
		V _{CC} = 6.0 V	4.2	3.2	-	4.2	-	4.2	-	V
V _{IL}	LOW-level input voltage	V _{CC} = 2.0 V	-	0.8	0.5	-	0.5	-	0.5	V
		V _{CC} = 4.5 V	-	2.1	1.35	-	1.35	-	1.35	V
		V _{CC} = 6.0 V	-	2.8	1.8	-	1.8	-	1.8	V
V _{OH}	HIGH-level output voltage	V _I = V _{IH} or V _{IL}								
		I _O = -20 μA; V _{CC} = 2.0 V	1.9	2.0	-	1.9	-	1.9	-	V
		I _O = -20 μA; V _{CC} = 4.5 V	4.4	4.5	-	4.4	-	4.4	-	V
		I _O = -20 μA; V _{CC} = 6.0 V	5.9	6.0	-	5.9	-	5.9	-	V
		I _O = -4 mA; V _{CC} = 4.5 V	3.98	4.32	-	3.84	-	3.7	-	V
I _O = -5.2 mA; V _{CC} = 6.0 V	5.48	5.81	-	5.34	-	5.2	-	V		
V _{OL}	LOW-level output voltage	V _I = V _{IH} or V _{IL}								
		I _O = 20 μA; V _{CC} = 2.0 V	-	0	0.1	-	0.1	-	0.1	V
		I _O = 20 μA; V _{CC} = 4.5 V	-	0	0.1	-	0.1	-	0.1	V
		I _O = 20 μA; V _{CC} = 6.0 V	-	0	0.1	-	0.1	-	0.1	V
		I _O = 4 mA; V _{CC} = 4.5 V	-	0.15	0.26	-	0.33	-	0.4	V
I _O = 5.2 mA; V _{CC} = 6.0 V	-	0.16	0.26	-	0.33	-	0.4	V		
I _I	input leakage current	V _I = V _{CC} or GND; V _{CC} = 6.0 V	-	-	±0.1	-	±1.0	-	±1.0	μA
I _{CC}	supply current	V _I = V _{CC} or GND; I _O = 0 A; V _{CC} = 6.0 V	-	-	8.0	-	80	-	160	μA

Table 6. Static characteristics ...continued

At recommended operating conditions; voltages are referenced to GND (ground = 0 V).

Symbol	Parameter	Conditions	25 °C			-40 °C to +85 °C		-40 °C to +125 °C		Unit
			Min	Typ	Max	Min	Max	Min	Max	
C _I	input capacitance		-	3.5	-	-	-	-	-	pF
74HCT123-Q100										
V _{IH}	HIGH-level input voltage	V _{CC} = 4.5 V to 5.5 V	2.0	1.6	-	2.0	-	2.0	-	V
V _{IL}	LOW-level input voltage	V _{CC} = 4.5 V to 5.5 V	-	1.2	0.8	-	0.8	-	0.8	V
V _{OH}	HIGH-level output voltage	V _I = V _{IH} or V _{IL} ; V _{CC} = 4.5 V								
		I _O = -20 μA	4.4	4.5	-	4.4	-	4.4	-	V
		I _O = -4 mA	3.98	4.32	-	3.84	-	3.7	-	V
V _{OL}	LOW-level output voltage	V _I = V _{IH} or V _{IL} ; V _{CC} = 4.5 V								
		I _O = 20 μA	-	0	0.1	-	0.1	-	0.1	V
		I _O = 4.0 mA	-	0.15	0.26	-	0.33	-	0.4	V
I _I	input leakage current	V _I = V _{CC} or GND; V _{CC} = 5.5 V	-	-	±0.1	-	±1.0	-	±1.0	μA
I _{CC}	supply current	V _I = V _{CC} or GND; I _O = 0 A; V _{CC} = 5.5 V	-	-	8.0	-	80	-	160	μA
ΔI _{CC}	additional supply current	per input pin; I _O = 0 A; V _I = V _{CC} - 2.1 V; other inputs at V _{CC} or GND; V _{CC} = 4.5 V to 5.5 V								
		pins n \bar{A} , nB	-	35	125	-	160	-	170	μA
		pin n \bar{RD}	-	50	180	-	225	-	245	μA
C _I	input capacitance		-	3.5	-	-	-	-	-	pF

10. Dynamic characteristics

Table 7. Dynamic characteristics

Voltages are referenced to GND (ground = 0 V); $C_L = 50$ pF unless otherwise specified; for test circuit see [Figure 12](#).

Symbol	Parameter	Conditions	25 °C			-40 °C to +85 °C		-40 °C to +125 °C		Unit	
			Min	Typ	Max	Min	Max	Min	Max		
74HC123-Q100											
t_{pd}	propagation delay	nRD, nA, nB to nQ or nQ; $C_{EXT} = 0$ pF; $R_{EXT} = 5$ kΩ; see Figure 9 [1]									
		$V_{CC} = 2.0$ V	-	83	255	-	320	-	385	ns	
		$V_{CC} = 4.5$ V	-	30	51	-	64	-	77	ns	
		$V_{CC} = 5$ V; $C_L = 15$ pF	-	26	-	-	-	-	-	ns	
	$V_{CC} = 6.0$ V	-	24	43	-	54	-	65	ns		
	nRD (reset) to nQ or nQ; $C_{EXT} = 0$ pF; $R_{EXT} = 5$ kΩ; see Figure 9	$V_{CC} = 2.0$ V	-	66	215	-	270	-	325	ns	
		$V_{CC} = 4.5$ V	-	24	43	-	54	-	65	ns	
		$V_{CC} = 5$ V; $C_L = 15$ pF	-	20	-	-	-	-	-	ns	
$V_{CC} = 6.0$ V		-	19	37	-	46	-	55	ns		
t_t	transition time	see Figure 9 [1]									
		$V_{CC} = 2.0$ V	-	19	75	-	95	-	110	ns	
		$V_{CC} = 4.5$ V	-	7	15	-	19	-	22	ns	
		$V_{CC} = 6.0$ V	-	6	13	-	16	-	19	ns	
t_w	pulse width	nA LOW; see Figure 10									
		$V_{CC} = 2.0$ V	100	8	-	125	-	150	-	ns	
		$V_{CC} = 4.5$ V	20	3	-	25	-	30	-	ns	
			$V_{CC} = 6.0$ V	17	2	-	21	-	26	-	ns
	nB HIGH; see Figure 10	$V_{CC} = 2.0$ V	100	17	-	125	-	150	-	ns	
		$V_{CC} = 4.5$ V	20	6	-	25	-	30	-	ns	
		$V_{CC} = 6.0$ V	17	5	-	21	-	26	-	ns	
	nRD LOW; see Figure 11	$V_{CC} = 2.0$ V	100	14	-	125	-	150	-	ns	
		$V_{CC} = 4.5$ V	20	5	-	25	-	30	-	ns	
		$V_{CC} = 6.0$ V	17	4	-	21	-	26	-	ns	
	nQ HIGH and nQ LOW; $V_{CC} = 5.0$ V; see Figure 10 and Figure 11 [2]	$C_{EXT} = 100$ nF; $R_{EXT} = 10$ kΩ	-	450	-	-	-	-	-	μs	
		$C_{EXT} = 0$ pF; $R_{EXT} = 5$ kΩ	-	75	-	-	-	-	-	ns	

Table 7. Dynamic characteristics ...continued

Voltages are referenced to GND (ground = 0 V); $C_L = 50$ pF unless otherwise specified; for test circuit see [Figure 12](#).

Symbol	Parameter	Conditions	25 °C			-40 °C to +85 °C		-40 °C to +125 °C		Unit
			Min	Typ	Max	Min	Max	Min	Max	
t_{trig}	retrigger time	\overline{nA} , nB; $C_{EXT} = 0$ pF; $R_{EXT} = 5$ k Ω ; $V_{CC} = 5.0$ V; see Figure 10	[3][4]	-	110	-	-	-	-	ns
R_{EXT}	external resistance	see Figure 7								
		$V_{CC} = 2.0$ V		10	-	1000	-	-	-	k Ω
		$V_{CC} = 5.0$ V		2	-	1000	-	-	-	k Ω
C_{EXT}	external capacitance	$V_{CC} = 5.0$ V; see Figure 7	[4]	-	-	-	-	-	-	pF
C_{PD}	power dissipation capacitance	per monostable; $V_I = GND$ to V_{CC}	[5]	-	54	-	-	-	-	pF

74HCT123-Q100

t_{PHL}	HIGH to LOW propagation delay	\overline{nRD} , \overline{nA} , nB to nQ or \overline{nQ} ; $C_{EXT} = 0$ pF; $R_{EXT} = 5$ k Ω ; see Figure 9									
		$V_{CC} = 4.5$ V	-	30	51	-	64	-	77	ns	
		$V_{CC} = 5$ V; $C_L = 15$ pF	-	26	-	-	-	-	-	-	ns
		\overline{nRD} (reset) to nQ or \overline{nQ} ; $C_{EXT} = 0$ pF; $R_{EXT} = 5$ k Ω ; see Figure 9									
		$V_{CC} = 4.5$ V	-	27	46	-	58	-	69	ns	
t_{PLH}	LOW to HIGH propagation delay	\overline{nRD} , \overline{nA} , nB to nQ or \overline{nQ} ; $C_{EXT} = 0$ pF; $R_{EXT} = 5$ k Ω ; see Figure 9									
		$V_{CC} = 4.5$ V	-	28	51	-	64	-	77	ns	
		$V_{CC} = 5$ V; $C_L = 15$ pF	-	26	-	-	-	-	-	-	ns
		\overline{nRD} (reset) to nQ or \overline{nQ} ; $C_{EXT} = 0$ pF; $R_{EXT} = 5$ k Ω ; see Figure 9									
		$V_{CC} = 4.5$ V	-	23	46	-	58	-	69	ns	
t_t	transition time	$V_{CC} = 4.5$ V; see Figure 9	[1]	-	7	15	-	19	-	22	ns
		$V_{CC} = 5$ V; $C_L = 15$ pF	-	23	-	-	-	-	-	-	ns
t_w	pulse width	$V_{CC} = 4.5$ V									
		\overline{nA} LOW; see Figure 10		20	3	-	25	-	30	-	ns
		nB HIGH; see Figure 10		20	5	-	25	-	30	-	ns
		\overline{nRD} LOW; see Figure 11		20	7	-	25	-	30	-	ns
		nQ HIGH and \overline{nQ} LOW; $V_{CC} = 5.0$ V; see Figure 10 and Figure 11	[2]								
$C_{EXT} = 100$ nF; $R_{EXT} = 10$ k Ω		-	450	-	-	-	-	-	-	μ s	
	$C_{EXT} = 0$ pF; $R_{EXT} = 5$ k Ω		-	75	-	-	-	-	-	ns	

Table 7. Dynamic characteristics ...continued

Voltages are referenced to GND (ground = 0 V); C_L = 50 pF unless otherwise specified; for test circuit see [Figure 12](#).

Symbol	Parameter	Conditions	25 °C			-40 °C to +85 °C		-40 °C to +125 °C		Unit
			Min	Typ	Max	Min	Max	Min	Max	
t _{trig}	retrigger time	nA, nB; C _{EXT} = 0 pF; R _{EXT} = 3 4 5 kΩ; V _{CC} = 5.0 V; see Figure 10	-	110	-	-	-	-	-	ns
R _{EXT}	external timing resistor	V _{CC} = 5.0 V; see Figure 7	2	-	1000	-	-	-	-	kΩ
C _{EXT}	external timing capacitor	V _{CC} = 5.0 V; see Figure 7 4	-	-	-	-	-	-	-	pF
C _{PD}	power dissipation capacitance	per monostable; V _I = GND to V _{CC} 5	-	56	-	-	-	-	-	pF

[1] t_{pd} is the same as t_{PHL} and t_{PLH}; t_i is the same as t_{THL} and t_{TLH}

[2] For other R_{EXT} and C_{EXT} combinations, see [Figure 7](#). If C_{EXT} > 10 nF, the following formula is valid.

t_w = K × R_{EXT} × C_{EXT}, where:

t_w = typical output pulse width in ns;

R_{EXT} = external resistor in kΩ;

C_{EXT} = external capacitor in pF;

K = constant = 0.45 for V_{CC} = 5.0 V and 0.55 for V_{CC} = 2.0 V.

The inherent test jig and pin capacitance at pins 15 and 7 (nR_{EXT}/C_{EXT}) is approximately 7 pF.

[3] The time to retrigger the monostable multivibrator depends on the values of R_{EXT} and C_{EXT}. The output pulse width is only extended when the time between the active-going edges of the trigger input pulses meets the minimum retrigger time. If C_{EXT} > 10 pF, the next formula (at V_{CC} = 5.0 V) for the setup time of a retrigger pulse is valid:

t_{trig} = 30 + 0.19 × R_{EXT} × C_{EXT}^{0.9} + 13 × R_{EXT}^{1.05}, where:

t_{trig} = retrigger time in ns;

C_{EXT} = external capacitor in pF; R_{EXT} = external resistor in kΩ.

The inherent test jig and pin capacitance at pins 15 and 7 (nR_{EXT}/C_{EXT}) is 7 pF.

[4] When the device is powered-up, initiate the device via a reset pulse, when C_{EXT} < 50 pF.

[5] C_{PD} is used to determine the dynamic power dissipation (P_D in μW).

P_D = C_{PD} × V_{CC}² × f_i + Σ(C_L × V_{CC}² × f_o) + 0.75 × C_{EXT} × V_{CC}² × f_o + D × 16 × V_{CC} where:

f_i = input frequency in MHz;

f_o = output frequency in MHz;

D = duty factor in %;

C_L = output load capacitance in pF;

V_{CC} = supply voltage in V;

C_{EXT} = timing capacitance in pF;

Σ(C_L × V_{CC}² × f_o) sum of outputs.

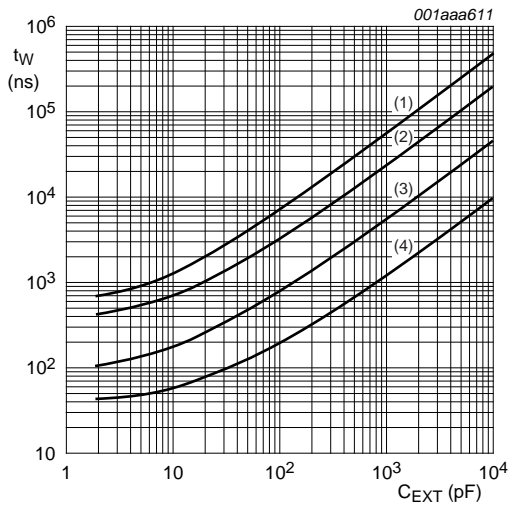

$V_{CC} = 5.0\text{ V}; T_{amb} = 25\text{ }^{\circ}\text{C}.$

- (1) $R_{EXT} = 100\text{ k}\Omega$
- (2) $R_{EXT} = 50\text{ k}\Omega$
- (3) $R_{EXT} = 10\text{ k}\Omega$
- (4) $R_{EXT} = 2\text{ k}\Omega$

Fig 7. Typical output pulse width as a function of the external capacitor value

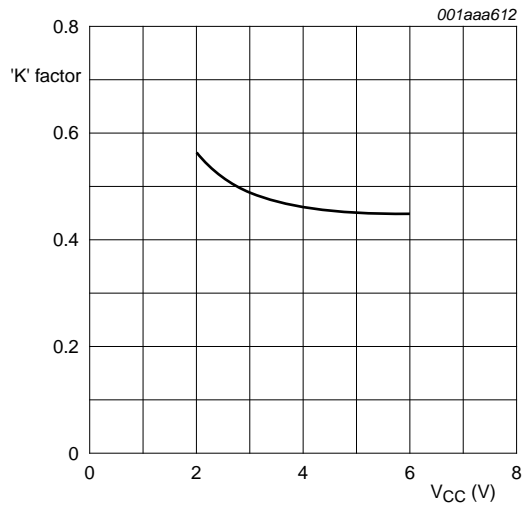

$C_{EXT} = 10\text{ nF}; R_{EXT} = 10\text{ k}\Omega\text{ to }100\text{ k}\Omega.$

$T_{amb} = 25\text{ }^{\circ}\text{C}.$

Fig 8. 74HC123-Q100 typical 'K' factor as function of V_{CC}

11. Waveforms

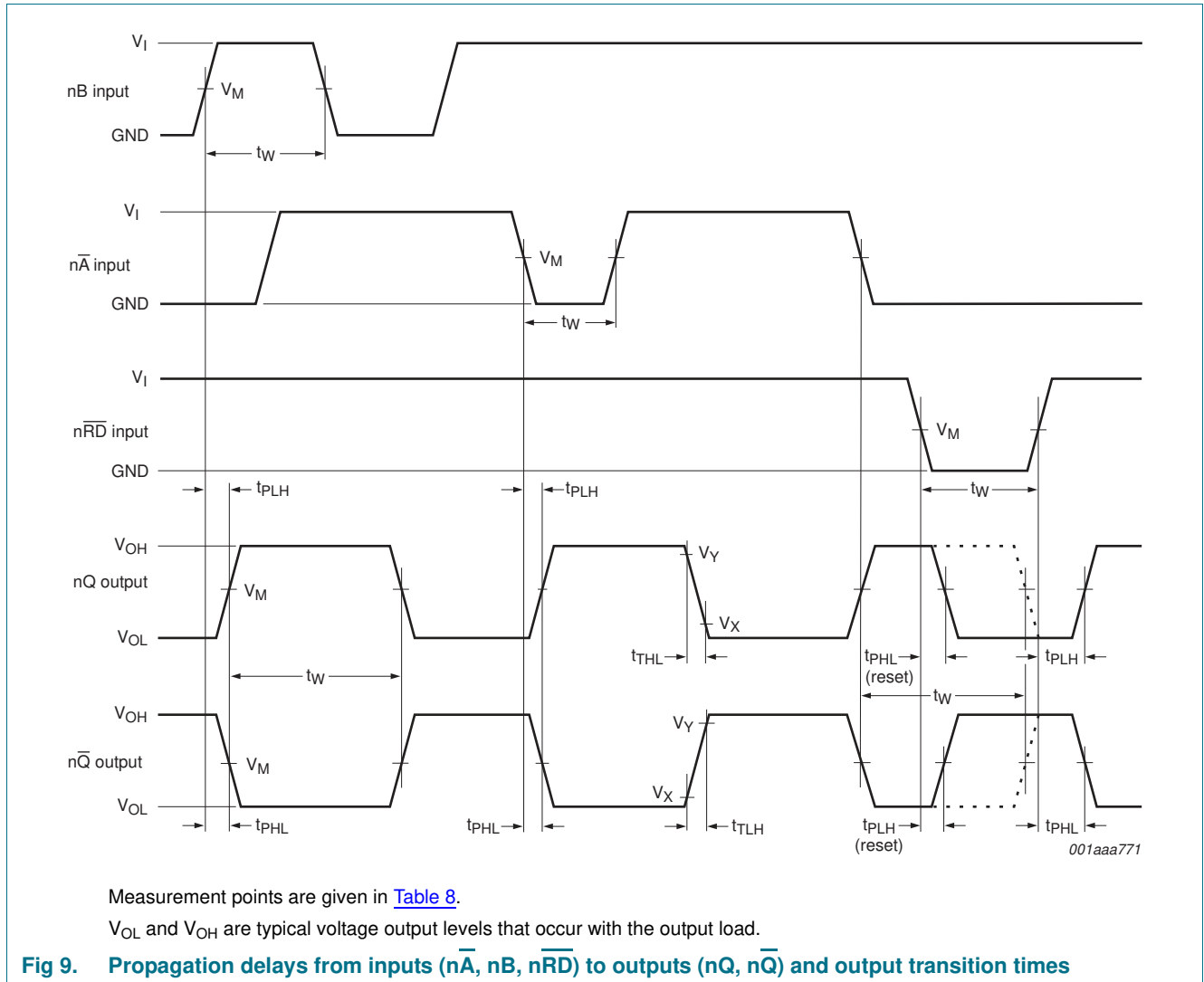

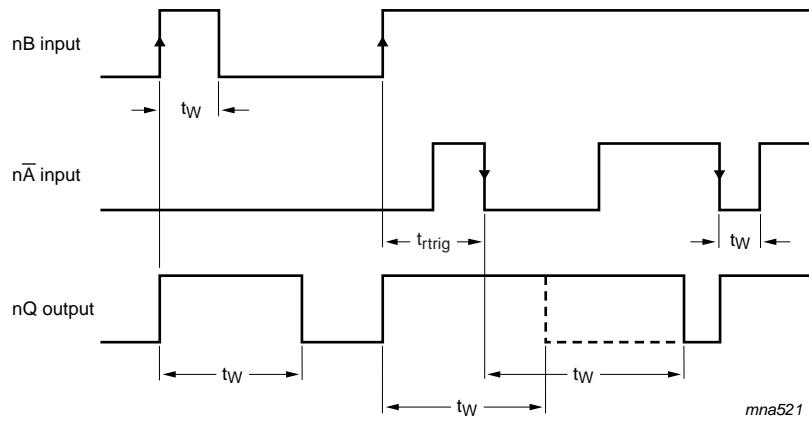

$n\overline{RD} = \text{HIGH}$

Fig 10. Output pulse control using retrigger pulse

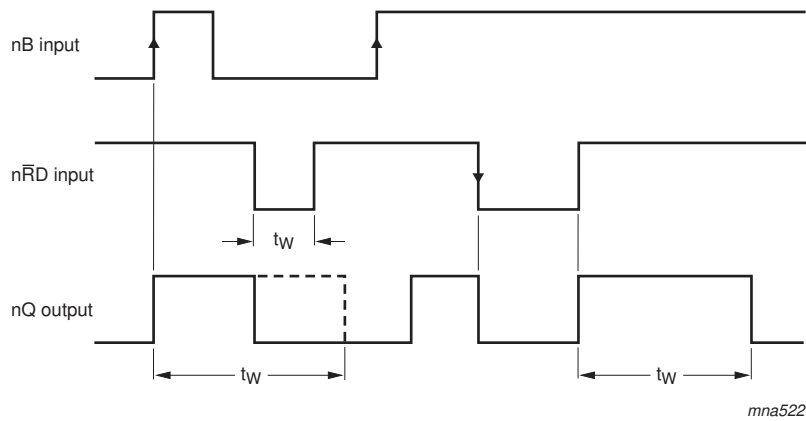

$n\overline{A} = \text{LOW}$

Fig 11. Output pulse control using reset input $n\overline{RD}$

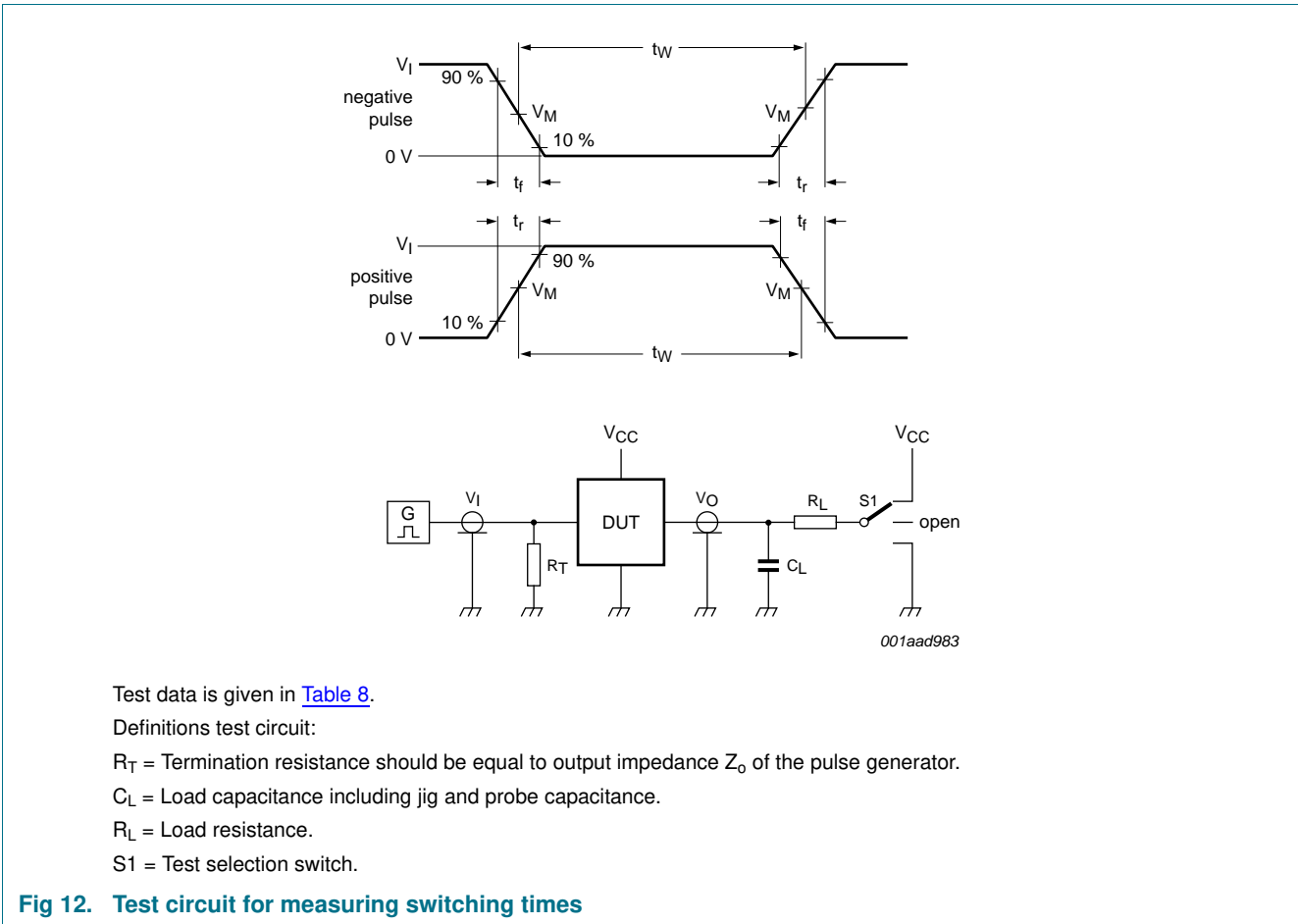

Table 8. Test data

Type	Input		Load		S1 position
	V_I	t_r, t_f	C_L	R_L	t_{PHL}, t_{PLH}
74HC123-Q100	V_{CC}	6 ns	15 pF, 50 pF	1 k Ω	open
74HCT123-Q100	3 V	6 ns	15 pF, 50 pF	1 k Ω	open

12. Application information

12.1 Timing component connections

The basic output pulse width is defined by the values of the external timing components R_{EXT} and C_{EXT} .

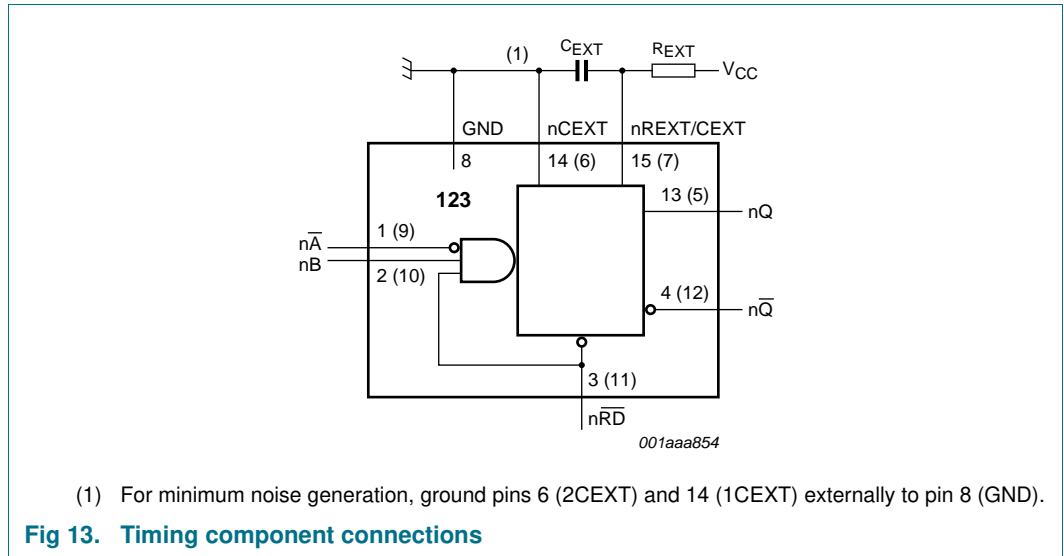

12.2 Power-up considerations

When the monostable is powered-up, it may produce an output pulse, with a pulse width defined by the values of R_{EXT} and C_{EXT} . This output pulse can be eliminated using the circuit shown in [Figure 14](#).

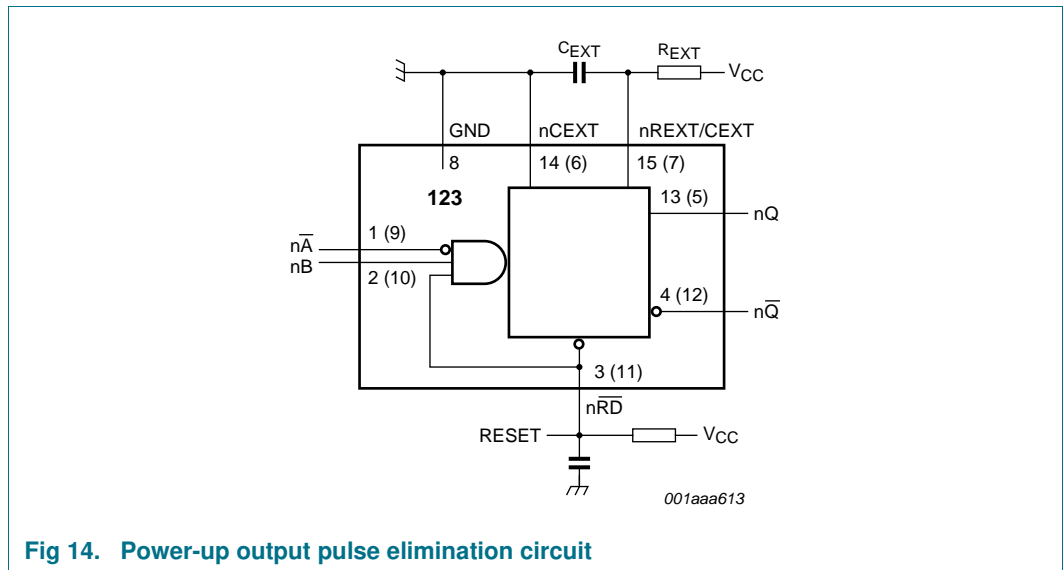

12.3 Power-down considerations

A large capacitor C_{EXT} may cause problems when powering-down the monostable due to the energy stored in this capacitor. When a system containing this device is powered-down or a rapid decrease of V_{CC} to zero occurs, the monostable may sustain damage. The damage is due to the capacitor discharging through the input protection diodes. To avoid this possibility, use a damping diode (D_{EXT}) and connect as shown in [Figure 15](#). D_{EXT} is preferably a germanium or Schottky type diode able to withstand large current surges.

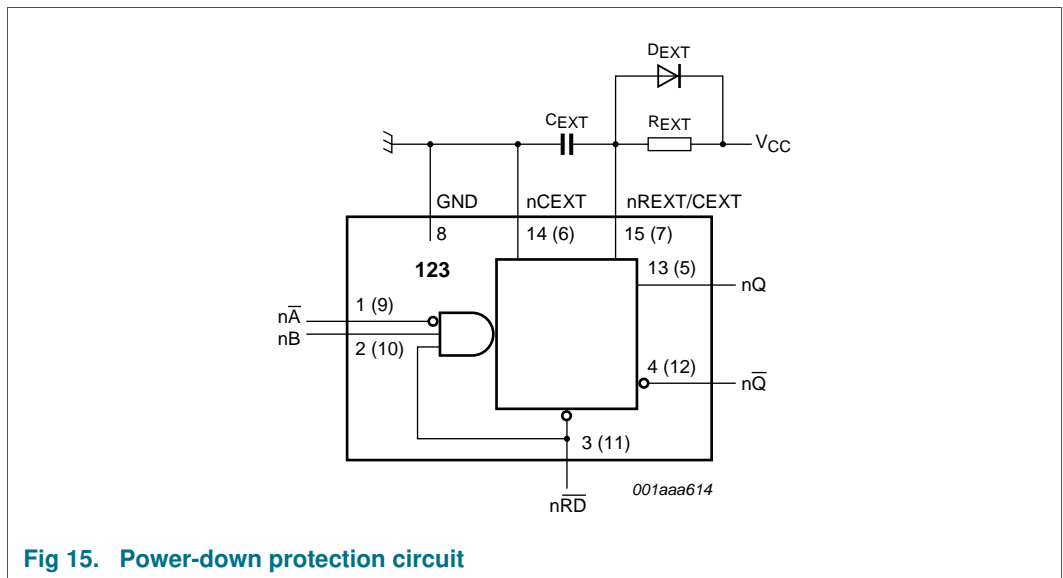

Fig 15. Power-down protection circuit

13. Package outline

SO16: plastic small outline package; 16 leads; body width 3.9 mm

SOT109-1

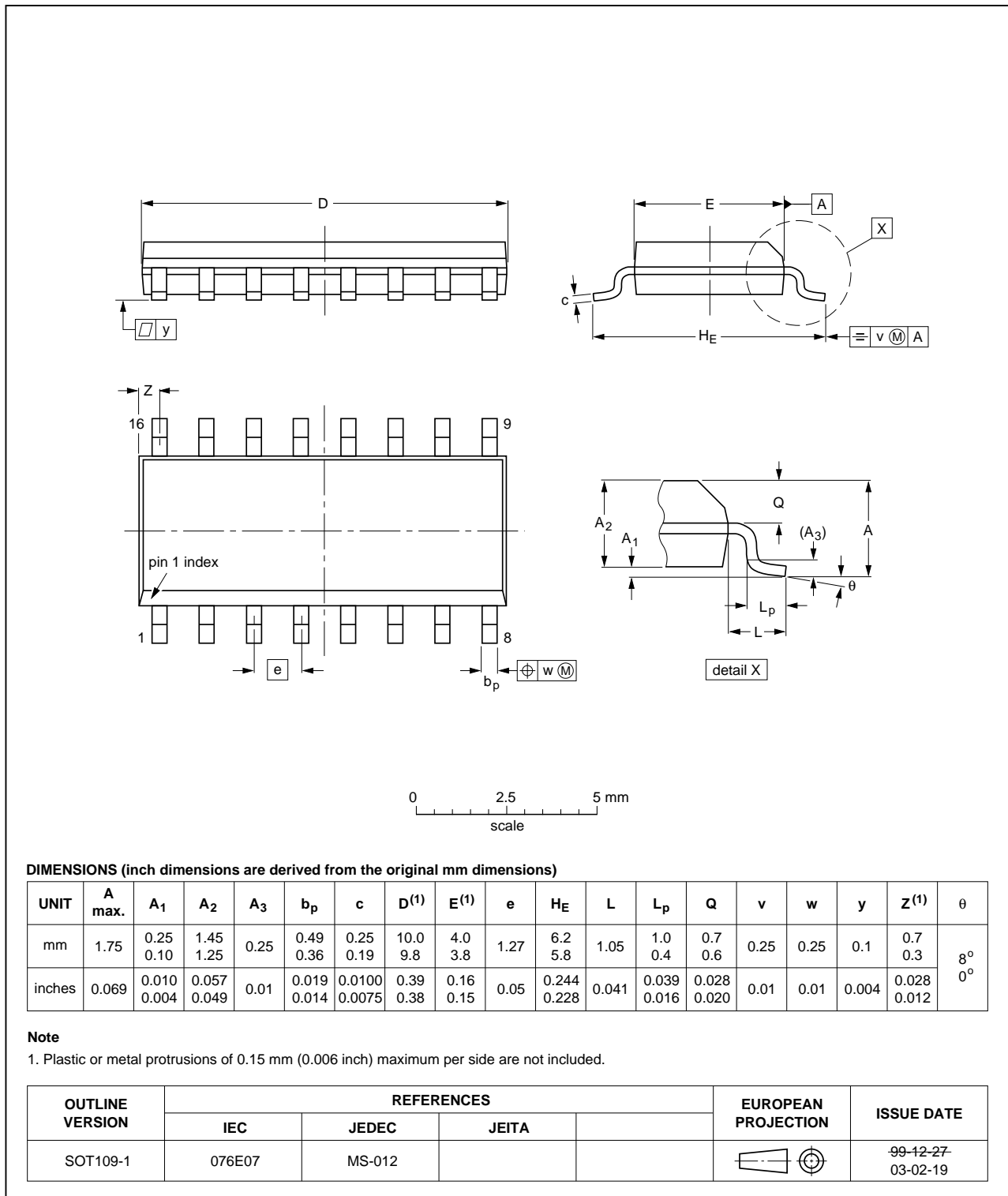

Fig 16. Package outline SOT109-1 (SO16)

TSSOP16: plastic thin shrink small outline package; 16 leads; body width 4.4 mm

SOT403-1

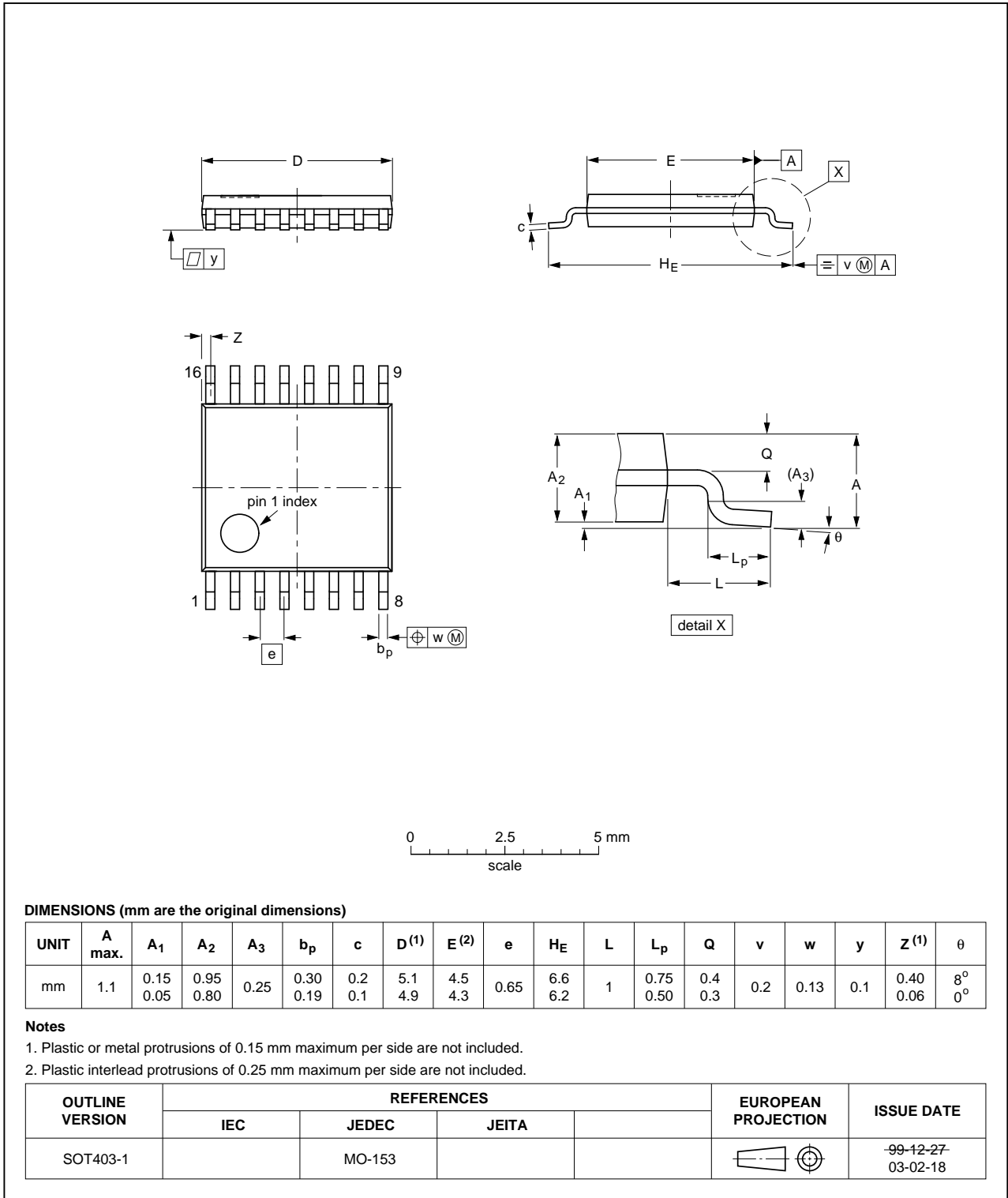

Fig 17. Package outline SOT403-1 (TSSOP16)

DHVQFN16: plastic dual in-line compatible thermal enhanced very thin quad flat package; no leads; 16 terminals; body 2.5 x 3.5 x 0.85 mm

SOT763-1

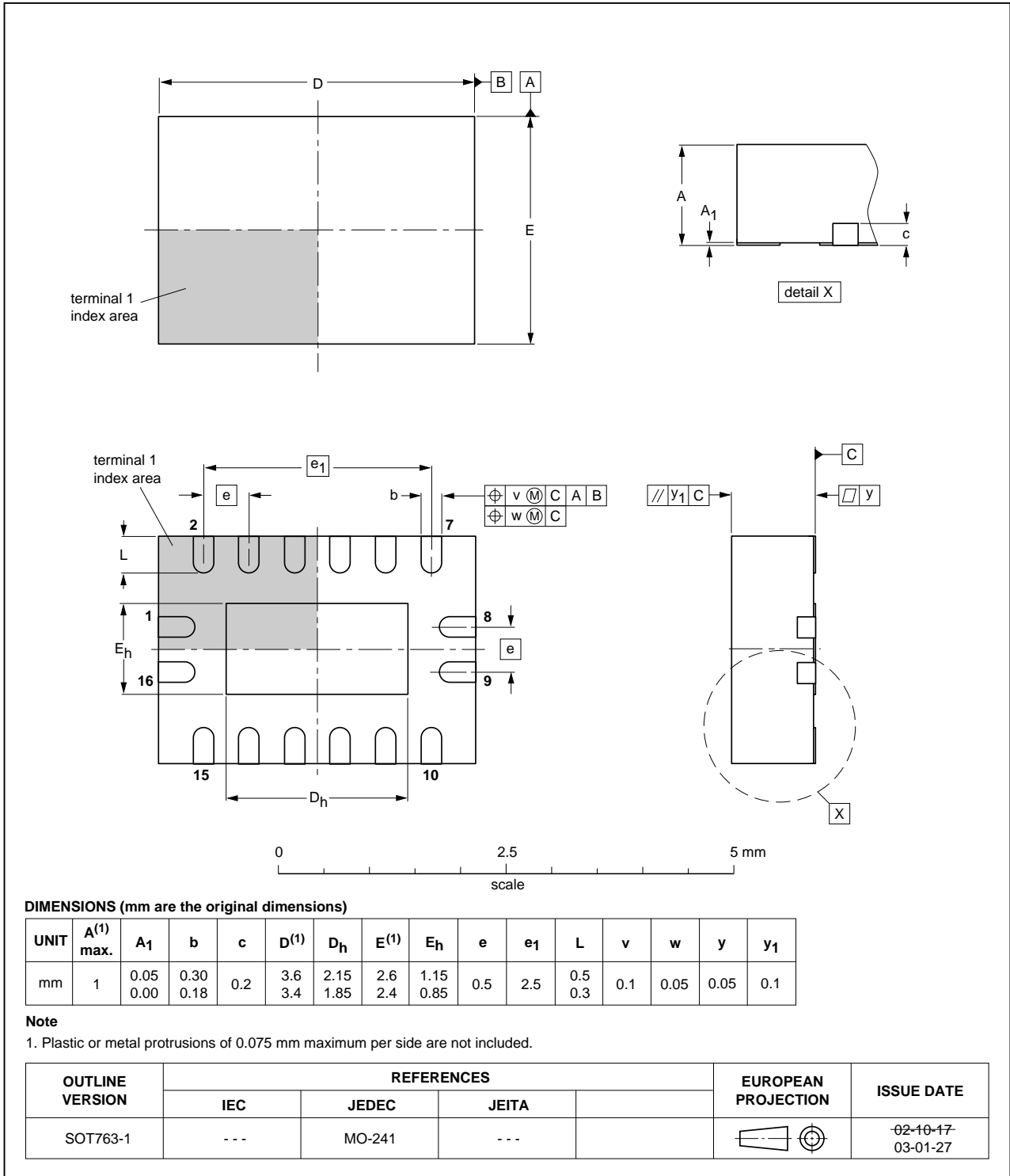

Fig 18. Package outline SOT763-1 (DHVQFN16)

14. Abbreviations

Table 9. Abbreviations

Acronym	Abbreviation
CMOS	Complementary Metal Oxide Semiconductor
DUT	Device Under Test
ESD	ElectroStatic Discharge
HBM	Human Body Model
LSTTL	Low-power Schottky Transistor-Transistor Logic
MM	Machine Model
MIL	Military

15. Revision history

Table 10. Revision history

Document ID	Release date	Data sheet status	Change notice	Supersedes
74HC_HCT123_Q100 v.1	20120801	Product data sheet	-	-

16. Legal information

16.1 Data sheet status

Document status ^{[1][2]}	Product status ^[3]	Definition
Objective [short] data sheet	Development	This document contains data from the objective specification for product development.
Preliminary [short] data sheet	Qualification	This document contains data from the preliminary specification.
Product [short] data sheet	Production	This document contains the product specification.

[1] Please consult the most recently issued document before initiating or completing a design.

[2] The term 'short data sheet' is explained in section "Definitions".

[3] The product status of device(s) described in this document may have changed since this document was published and may differ in case of multiple devices. The latest product status information is available on the Internet at URL <http://www.nxp.com>.

16.2 Definitions

Draft — The document is a draft version only. The content is still under internal review and subject to formal approval, which may result in modifications or additions. NXP Semiconductors does not give any representations or warranties as to the accuracy or completeness of information included herein and shall have no liability for the consequences of use of such information.

Short data sheet — A short data sheet is an extract from a full data sheet with the same product type number(s) and title. A short data sheet is intended for quick reference only and should not be relied upon to contain detailed and full information. For detailed and full information see the relevant full data sheet, which is available on request via the local NXP Semiconductors sales office. In case of any inconsistency or conflict with the short data sheet, the full data sheet shall prevail.

Product specification — The information and data provided in a Product data sheet shall define the specification of the product as agreed between NXP Semiconductors and its customer, unless NXP Semiconductors and customer have explicitly agreed otherwise in writing. In no event however, shall an agreement be valid in which the NXP Semiconductors product is deemed to offer functions and qualities beyond those described in the Product data sheet.

16.3 Disclaimers

Limited warranty and liability — Information in this document is believed to be accurate and reliable. However, NXP Semiconductors does not give any representations or warranties, expressed or implied, as to the accuracy or completeness of such information and shall have no liability for the consequences of use of such information. NXP Semiconductors takes no responsibility for the content in this document if provided by an information source outside of NXP Semiconductors.

In no event shall NXP Semiconductors be liable for any indirect, incidental, punitive, special or consequential damages (including - without limitation - lost profits, lost savings, business interruption, costs related to the removal or replacement of any products or rework charges) whether or not such damages are based on tort (including negligence), warranty, breach of contract or any other legal theory.

Notwithstanding any damages that customer might incur for any reason whatsoever, NXP Semiconductors' aggregate and cumulative liability towards customer for the products described herein shall be limited in accordance with the *Terms and conditions of commercial sale* of NXP Semiconductors.

Right to make changes — NXP Semiconductors reserves the right to make changes to information published in this document, including without limitation specifications and product descriptions, at any time and without notice. This document supersedes and replaces all information supplied prior to the publication hereof.

Suitability for use in automotive applications — This NXP Semiconductors product has been qualified for use in automotive applications. Unless otherwise agreed in writing, the product is not designed, authorized or warranted to be suitable for use in life support, life-critical or safety-critical systems or equipment, nor in applications where failure or malfunction of an NXP Semiconductors product can reasonably be expected to result in personal injury, death or severe property or environmental damage. NXP Semiconductors and its suppliers accept no liability for inclusion and/or use of NXP Semiconductors products in such equipment or applications and therefore such inclusion and/or use is at the customer's own risk.

Applications — Applications that are described herein for any of these products are for illustrative purposes only. NXP Semiconductors makes no representation or warranty that such applications will be suitable for the specified use without further testing or modification.

Customers are responsible for the design and operation of their applications and products using NXP Semiconductors products, and NXP Semiconductors accepts no liability for any assistance with applications or customer product design. It is customer's sole responsibility to determine whether the NXP Semiconductors product is suitable and fit for the customer's applications and products planned, as well as for the planned application and use of customer's third party customer(s). Customers should provide appropriate design and operating safeguards to minimize the risks associated with their applications and products.

NXP Semiconductors does not accept any liability related to any default, damage, costs or problem which is based on any weakness or default in the customer's applications or products, or the application or use by customer's third party customer(s). Customer is responsible for doing all necessary testing for the customer's applications and products using NXP Semiconductors products in order to avoid a default of the applications and the products or of the application or use by customer's third party customer(s). NXP does not accept any liability in this respect.

Limiting values — Stress above one or more limiting values (as defined in the Absolute Maximum Ratings System of IEC 60134) will cause permanent damage to the device. Limiting values are stress ratings only and (proper) operation of the device at these or any other conditions above those given in the Recommended operating conditions section (if present) or the Characteristics sections of this document is not warranted. Constant or repeated exposure to limiting values will permanently and irreversibly affect the quality and reliability of the device.

Terms and conditions of commercial sale — NXP Semiconductors products are sold subject to the general terms and conditions of commercial sale, as published at <http://www.nxp.com/profile/terms>, unless otherwise agreed in a valid written individual agreement. In case an individual agreement is concluded only the terms and conditions of the respective agreement shall apply. NXP Semiconductors hereby expressly objects to applying the customer's general terms and conditions with regard to the purchase of NXP Semiconductors products by customer.

No offer to sell or license — Nothing in this document may be interpreted or construed as an offer to sell products that is open for acceptance or the grant, conveyance or implication of any license under any copyrights, patents or other industrial or intellectual property rights.

Export control — This document as well as the item(s) described herein may be subject to export control regulations. Export might require a prior authorization from competent authorities.

Translations — A non-English (translated) version of a document is for reference only. The English version shall prevail in case of any discrepancy between the translated and English versions.

16.4 Trademarks

Notice: All referenced brands, product names, service names and trademarks are the property of their respective owners.

17. Contact information

For more information, please visit: <http://www.nxp.com>

For sales office addresses, please send an email to: salesaddresses@nxp.com

18. Contents

1	General description	1
2	Features and benefits	1
3	Ordering information	2
4	Functional diagram	2
5	Pinning information	4
5.1	Pinning	4
5.2	Pin description	4
6	Functional description	5
7	Limiting values	5
8	Recommended operating conditions	6
9	Static characteristics	6
10	Dynamic characteristics	8
11	Waveforms	12
12	Application information	15
12.1	Timing component connections	15
12.2	Power-up considerations	15
12.3	Power-down considerations	16
13	Package outline	17
14	Abbreviations	20
15	Revision history	20
16	Legal information	21
16.1	Data sheet status	21
16.2	Definitions	21
16.3	Disclaimers	21
16.4	Trademarks	22
17	Contact information	22
18	Contents	23

Please be aware that important notices concerning this document and the product(s) described herein, have been included in section 'Legal information'.

© NXP B.V. 2012.

All rights reserved.

For more information, please visit: <http://www.nxp.com>

For sales office addresses, please send an email to: salesaddresses@nxp.com

Date of release: 1 August 2012

Document identifier: 74HC_HCT123_Q100