

© - TE Connectivity. All Rights Reserved.

REVISIONS					
P	LTR	DESCRIPTION	DATE	DWN	APVD
	R4	REVISED PER ECN-22-156403	06JUN2022	RK	CSD

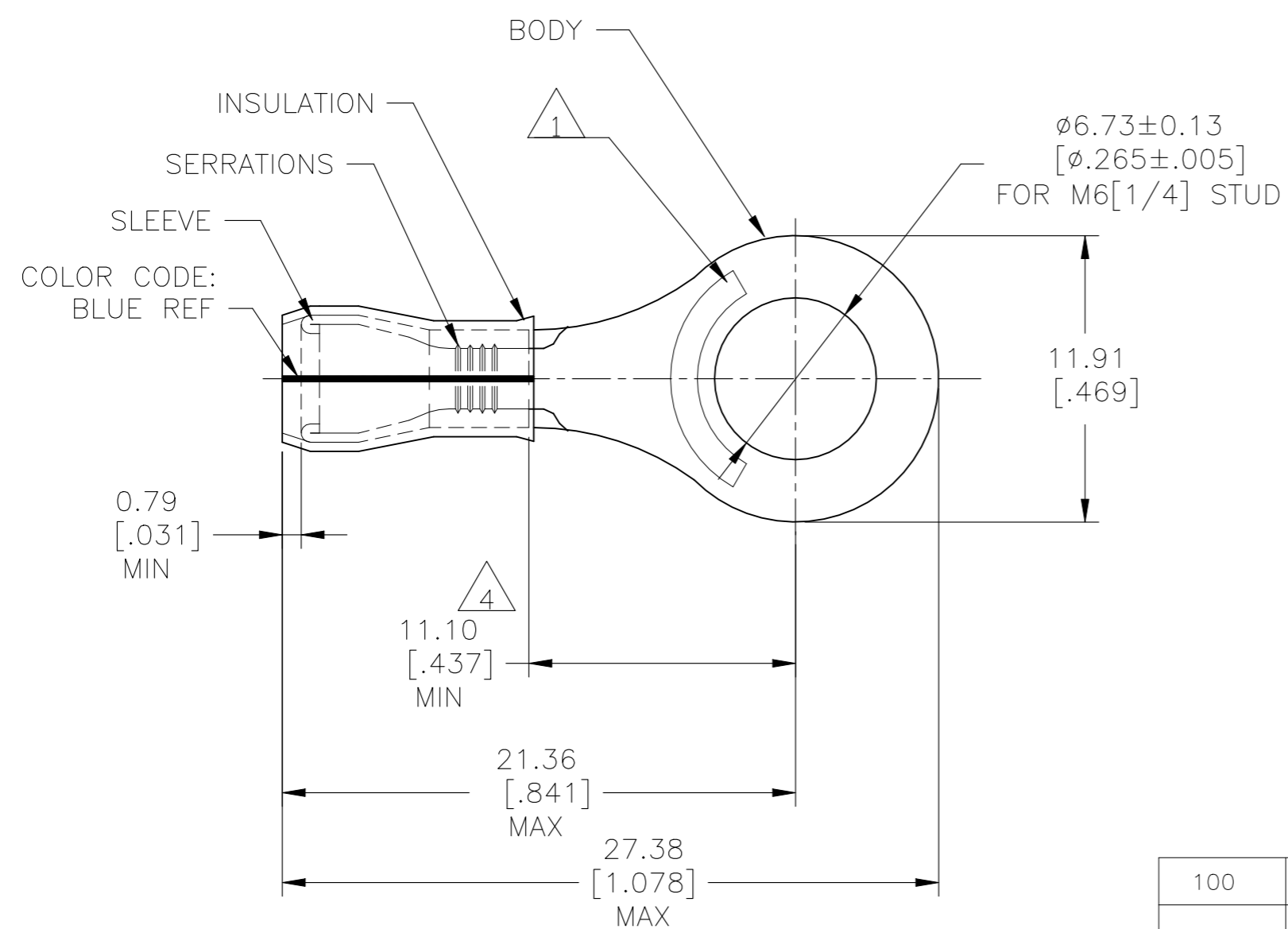

QTY	PACKAGE TYPE	MATERIAL & FINISH	PART NO
100	LOOSE PIECE, BOX	SAME AS 53419-1	8-53419-1
1000	LOOSE PIECE	BODY: COPPER PER ASTM B152 TIN/LEAD (93-7) PLATE PER ASTM B545 (3% MIN LEAD CONTENT) SLEEVE: COPPER PER ASTM B152 TIN/LEAD (93-7) PLATE PER ASTM B545 (3% MIN LEAD CONTENT) INSULATION: PVF2, COLOR-NATURAL	53419-1

AMP INCORPORATED CUSTOMER SERVICE SYSTEMS	
FOR ADDITIONAL PRODUCT INFORMATION OR COPIES OF DRAWINGS AND TECHNICAL DOCUMENTS	PRODUCT INFORMATION CENTER 1-800-522-6752
FOR APPLICATION TOOLING INFORMATION	TOOLING ASSISTANCE CENTER 1-800-722-1111
FOR ORDER ENTRY	1-800-526-5142

MAX RECOMMENDED OPERATING TEMPERATURE: 150°C [302°F] MAX
VOLTAGE RATING: N/A
CIRCULAR MIL AREA: 1.04-2.62mm² [2,050-5,180] STRANDED

THIS DRAWING IS A CONTROLLED DOCUMENT.	
DIMENSIONS: mm [INCHES]	TOLERANCES UNLESS OTHERWISE SPECIFIED:
	0 PLC ± - 1 PLC ± - 2 PLC ± - 3 PLC ± 0.20[.008] 4 PLC ± - ANGLES ± -
MATERIAL SEE TABLE	FINISH SEE TABLE

DWN JR RUTH 25OCT07	NAME TERMINAL, RING TONGUE, PVF2 , P.I.D.G. WIRE SIZE: 16-14 AWG
CHK T MICHIELUTTI 25OCT07	
APVD T MICHIELUTTI 25OCT07	
PRODUCT SPEC -	
APPLICATION SPEC -	RESTRICTED TO -
WEIGHT -	SIZE A3

STE TE Connectivity	
SIZE A3	CAGE CODE 00779
DRAWING NO C-53419	RESTRICTED TO -
CUSTOMER DRAWING	SCALE 4:1
SHEET 1 OF 1	REV R4