



**Pb-free
HEAT**



1104LS Series

Single Color PLCC-2 Type
(High Reliability type, V-Series)

Features

Package	PLCC-2 Bathtub Type. Water clear resin	
Product features	<ul style="list-style-type: none"> • Outer Dimension 3.5 x 2.8 x 1.9mm(L x W x H) • Wide operation temperature range. Storage Temperature : -40°C~120°C Operating Temperature : -40°C~100°C Operation Guarantee • Spatial distribution characteristics. (201/2 : 120deg) • Corresponding to a use requiring high reliability in cars etc... • Ramification of luminosity group sorting. It is possible to have a uniform transmission with little irregularities even when several are lined up. • Lead-free soldering compatible • RoHS compliant 	
Dominant wavelength	Blue : 470nm (VCPB,VCLB) Green : 525nm (VCPG,VCMG) 561nm (VFHG,VFJG,VFGG) Yellow Green : 570nm (VFHP,VFJP,VFGP) Yellow : 589nm (VFHY,VFJY,VFGY) Orange : 606nm (VFHA,VFJA,VFGA) Red : 616nm (VFHV,VFJV,VFGV) 626nm (VFHR,VFJR,VFGR)	
Spatial distribution	120 deg.	
Die materials	VC□□:InGaN、 VF□□ :AlGaInP	
Rank grouping parameter	Sorted by luminous intensity and wavelength and taped according to rank.	
Assembly methods (customer)	Corresponding to surface mounter.	
Soldering methods	Corresponding to reflow soldering / Manual Soldering	
Taping dimensions	2,000pcs(standard)per reel in a 8mm width tape. Reel diameter : φ180mm	
ESD-withstand voltage	AlGaInP:Up to 2kV (HBM), InGaN:Up to 1kV(HBM)	※ Reference

Recommended Applications

SW lighting for car indicators, meter panel, car audio and heater control, etc...

Color and Luminous Intensity

(Ta=25°C)

Part No.	Material	Emitted Color	Lens Color	Dominant Wavelength		Luminous Intensity			Luminous Flux		Optical Efficiency (lm/W) (Reference)
				λ_d (nm)		I_v (mcd)			ϕ_v (lm)		
				TYP.	I_F (mA)	MIN.	TYP.	I_F (mA)	TYP.	I_F (mA)	
VCPB1104LS	InGaN	Blue	Water Clear	470	10	33	60	10	0.19	10	6.1
VCLB1104LS					30	150	260	30	0.85	30	8.9
VCPG1104LS		Green		525	10	120	260	10	0.83	10	26.8
VCMG1104LS					30	330	700	30	2.20	30	22.9
VFHG1104LS	AlGaInP	Green	Water Clear	561	20	18	25	20	0.10	20	2.5
VFJG1104LS					20	27	36	20	0.11	20	2.8
VFGG1104LS					50	68	90	50	0.28	50	2.5
VFHP1104LS	AlGaInP	Yellw Green	Water Clear	570	20	56	78	20	0.30	20	7.5
VFJP1104LS					20	82	110	20	0.35	20	8.8
VFGP1104LS					50	120	180	50	0.57	50	5.2
VFHY1104LS	AlGaInP	Yellw	Water Clear	589	20	120	170	20	0.54	20	13.5
VFJY1104LS					20	180	255	20	0.81	20	20.3
VFGY1104LS					50	470	645	50	2.03	50	18.5
VFHA1104LS	AlGaInP	Orange	Water Clear	606	20	120	170	20	0.54	20	13.5
VFJA1104LS					20	180	255	20	0.81	20	20.3
VFGA1104LS					50	560	910	50	2.46	50	22.4
VFHV1104LS	AlGaInP	Red	Water Clear	616	20	120	170	20	0.54	20	13.5
VFJV1104LS					20	180	230	20	0.73	20	18.3
VFGV1104LS					50	680	940	50	2.46	50	22.4
VFHR1104LS	AlGaInP	Red	Water Clear	632	20	100	140	20	0.44	20	11.0
VFJR1104LS					20	150	210	20	0.66	20	16.5
VFGR1104LS					50	330	500	50	1.57	50	14.3

※Note : The luminous intensity(I_v) and dominant wavelength (λ_d) above are the setup values of the sorting machine.
(Tolerance : I_v ... $\pm 10\%$, λ_d ... ± 1 nm)

Absolute Maximum Ratings

(Ta=25°C)

Item	Symbol	VCPB	VCLB	VCPG	VCMG	VFHG	VFJG	VFGG	Unit
Power Dissipation	P_d	76	117	76	120	78	78	130	mW
Continuous Forward Current	I_F	20	30	20	30	30	30	50	mA
Repetitive Peak Forward Current ^{※1}	I_{FRM}	100	100	100	100	100	100	100	mA
Derating ^{※2}	ΔI_F	0.57	0.86	0.57	0.86	0.86	0.86	1.43	mA/°C
	ΔI_{FRM}	2.86	2.86	2.86	2.86	2.86	2.86	2.04	mA/°C
Reverse Voltage	V_R	5	5	5	5	5	5	5	V
Operating Temperature	T_{opr}	-40~+100							°C
Storage Temperature	T_{stg}	-40~+120							°C

Item	Symbol	VFHP	VFJP	VFGP	VFHY	VFJY	VFGY	Unit
Power Dissipation	P_d	78	78	189	78	78	189	mW
Continuous Forward Current	I_F	30	30	50	30	30	70	mA
Repetitive Peak Forward Current ^{※1}	I_{FRM}	100	100	100	100	100	100	mA
Derating ^{※2}	ΔI_F	0.86	0.86	1.43	0.86	0.86	1.43	mA/°C
	ΔI_{FRM}	2.86	2.86	2.04	2.86	2.86	2.04	mA/°C
Reverse Voltage	V_R	5	5	5	5	5	5	V
Operating Temperature	T_{opr}	-40~+100						°C
Storage Temperature	T_{stg}	-40~+120						°C

※1 I_{FRM} Measurement condition / VC□□ : Pulse Width \leq 0.1ms, Duty \leq 1/10

VF□□ : Pulse Width \leq 1.0ms, Duty \leq 1/20

※2 VFGY : Ta=71°C or higher

Other : Ta=85°C or higher

Absolute Maximum Ratings

Item	Symbol	VFHA	VFJA	VFGA	Unit
Power Dissipation	P_d	78	78	189	mW
Continuous Forward Current	I_F	30	30	70	mA
Repetitive Peak Forward Current ※1	I_{FRM}	100	100	100	mA
Derating ※2	ΔI_F	0.86	0.86	1.43	mA/°C
	ΔI_{FRM}	2.86	2.86	2.04	mA/°C
Reverse Voltage	V_R	5	5	5	V
Operating Temperature	T_{opr}	-40~+100			°C
Storage Temperature	T_{stg}	-40~+120			°C

Item	Symbol	VFHV	VFJV	VFGV	VFHR	VFJR	VFGR	Unit
Power Dissipation	P_d	78	78	189	78	78	189	mW
Continuous Forward Current	I_F	30	30	70	30	30	70	mA
Repetitive Peak Forward Current ※1	I_{FRM}	100	100	100	100	100	100	mA
Derating ※2	ΔI_F	0.86	0.86	1.43	0.86	0.86	1.43	mA/°C
	ΔI_{FRM}	2.86	2.86	2.04	2.86	2.86	2.04	mA/°C
Reverse Voltage	V_R	5	5	5	5	5	5	V
Operating Temperature	T_{opr}	-40~+100						°C
Storage Temperature	T_{stg}	-40~+120						°C

※1 I_{FRM} Measurement condition / VC□□ : Pulse Width \leq 0.1ms, Duty \leq 1/10

VF□□ : Pulse Width \leq 1.0ms, Duty \leq 1/20

※2 VFGA,VFGV,VFGR : Ta=71°C or higher

Other : Ta=85°C or higher

Thermal Characteristics

Item	Symbol	Ratings						Unit
		VCP□	VCLB	VCMG	VFH□	VFJ□	VFG□	
Junction Temperature (MAX.)	T_j	120	120	120	120	120	120	°C
Thermal Resistance (TYP.) (Junction/ambient)	$R_{(th\ j-a)}$	300	250	270	350	350	260	°C/W
Thermal Resistance (TYP.) (Junction/Solder Point)	$R_{(th\ j-s)}$	150	100	100	200	200	110	°C/W

※ $R_{th(j-a)}$ Measurement Condition / Substrate: FR4(t=1.6mm) Pattern Size: 16mm².



1104LS Series

Single Color PLCC-2 Type
(High Reliability type, V-Series)

Electro-Optical Characteristics

(Ta=25°C)

Item	Forward Voltage			Reverse Current		Wavelength				Half Intensity Angle	
	V _F (V)			I _R (μA)		Peak	Dominant	Spectral Line Half Width	Conditions	2θ1/2(deg.)	
	TYP.	MAX.	I _F (mA)	TYP.	I _F (mA)	λ _p (nm)	λ _d (nm)	Δλ (nm)		TYP.	I _F (mA)
VCPB1104LS	3.1	3.7	10	10		462	470	22	10		10
VCLB1104LS	3.2	3.9	30								30
VCPG1104LS	3.1	3.7	10								10
VCMG1104LS	3.2	3.9	30								30
VFHG1104LS	2.0	2.5	20	100	5			20	20	120	20
VFJG1104LS	2.0	2.5	20								20
VFGG1104LS	2.2	2.6	50								50
VFHP1104LS	2.0	2.5	20								20
VFJP1104LS	2.0	2.5	20								20
VFGP1104LS	2.2	2.6	50								50
VFHY1104LS	2.0	2.5	20								20
VFJY1104LS	2.0	2.5	20								20
VFGY1104LS	2.2	2.6	50								50
VFHA1104LS	2.0	2.5	20								20
VFJA1104LS	2.0	2.5	20								20
VFGA1104LS	2.2	2.6	50								50
VFHV1104LS	2.0	2.5	20								20
VFJV1104LS	2.0	2.5	20								20
VFGV1104LS	2.2	2.6	50								50
VFHR1104LS	2.0	2.5	20								20
VFJR1104LS	2.0	2.5	20	20							
VFGR1104LS	2.2	2.6	50	50							

※Note: The dominant wave length (λ_d) above is the setup value of the sorting machine.
(Tolerance : λ_d...±1nm)

Luminous Intensity Rank

(Ta=25°C)

Intensity Tolerance each Rank : +/-10%

Rank	I _v (mcd)		VCPB	VCLB	VCPG	VCMG	VFHG	VFJG	VFGG
	MIN.	MAX.	I _F =10mA	I _F =30mA	I _F =10mA	I _F =30mA	I _F =20mA	I _F =20mA	I _F =50mA
B1	10	12							
B2	12	15							
B3	15	18							
B4	18	22					B4		
B5	22	27					B6		
B6	27	33					B6	B6	
B7	33	39	B7						
B8	39	47						B8	
B9	47	56							
BX	56	68							
BY	68	82							BY
BZ	82	100	BZ						
C1	100	120							C1
C2	120	150			C2				
C3	150	180		C3					
C4	180	220							
C5	220	270							
C6	270	330							
C7	330	390		C7	C7	C7			
C8	390	470							
C9	470	560							
CX	560	680							
CY	680	820							
CZ	820	1,000				CZ			
D1	1,000	1,200							
D2	1,200	1,500							
D3	1,500	1,800							
D4	1,800	2,200							

※ Please contact our sales staff concerning rank designation.

Luminous Intensity Rank

(Ta=25°C)

Intensity Tolerance each Rank : +/-10%

Rank	I _v (mcd)		VFHP	VFJP	VFGP	VFHY	VFJY	VFGY
	MIN.	MAX.	I _F =20mA	I _F =20mA	I _F =50mA	I _F =20mA	I _F =20mA	I _F =50mA
B1	10	12						
B2	12	15						
B3	15	18						
B4	18	22						
B5	22	27						
B6	27	33						
B7	33	39						
B8	39	47						
B9	47	56						
BX	56	68	BX					
BY	68	82						
BZ	82	100		BZ				
C1	100	120	C1					
C2	120	150			C2	C2		
C3	150	180		C3				
C4	180	220				C4	C4	
C5	220	270			C5			
C6	270	330					C6	
C7	330	390						
C8	390	470						
C9	470	560						C9
CX	560	680						
CY	680	820						CY
CZ	820	1,000						
D1	1,000	1,200						
D2	1,200	1,500						
D3	1,500	1,800						
D4	1,800	2,200						

※ランク指定については、担当営業へお問い合わせください。

Luminous Intensity Rank

(Ta=25°C)

Intensity Tolerance each Rank : +/-10%

Rank	I _v (mcd)		VFHA	VFJA	VFGA	VFHV	VFJV	VFGV	VFHR	VFJR	VFGR
	MIN.	MAX.	I _f =20mA	I _f =20mA	I _f =50mA	I _f =20mA	I _f =20mA	I _f =50mA	I _f =20mA	I _f =20mA	I _f =50mA
B1	10	12									
B2	12	15									
B3	15	18									
B4	18	22									
B5	22	27									
B6	27	33									
B7	33	39									
B8	39	47									
B9	47	56									
BX	56	68									
BY	68	82									
BZ	82	100									
C1	100	120							C1		
C2	120	150	C2			C2			C3		
C3	150	180				C4	C4			C3	
C4	180	220	C4	C4			C4				
C5	220	270								C5	
C6	270	330		C6			C6				
C7	330	390									C7
C8	390	470									
C9	470	560									
CX	560	680									
CY	680	820			CY			CY			CY
CZ	820	1,000									
D1	1,000	1,200			D1			D1			
D2	1,200	1,500									
D3	1,500	1,800									
D4	1,800	2,200									

※ Please contact our sales staff concerning rank designation.

Color Tone Groups (λ_d)

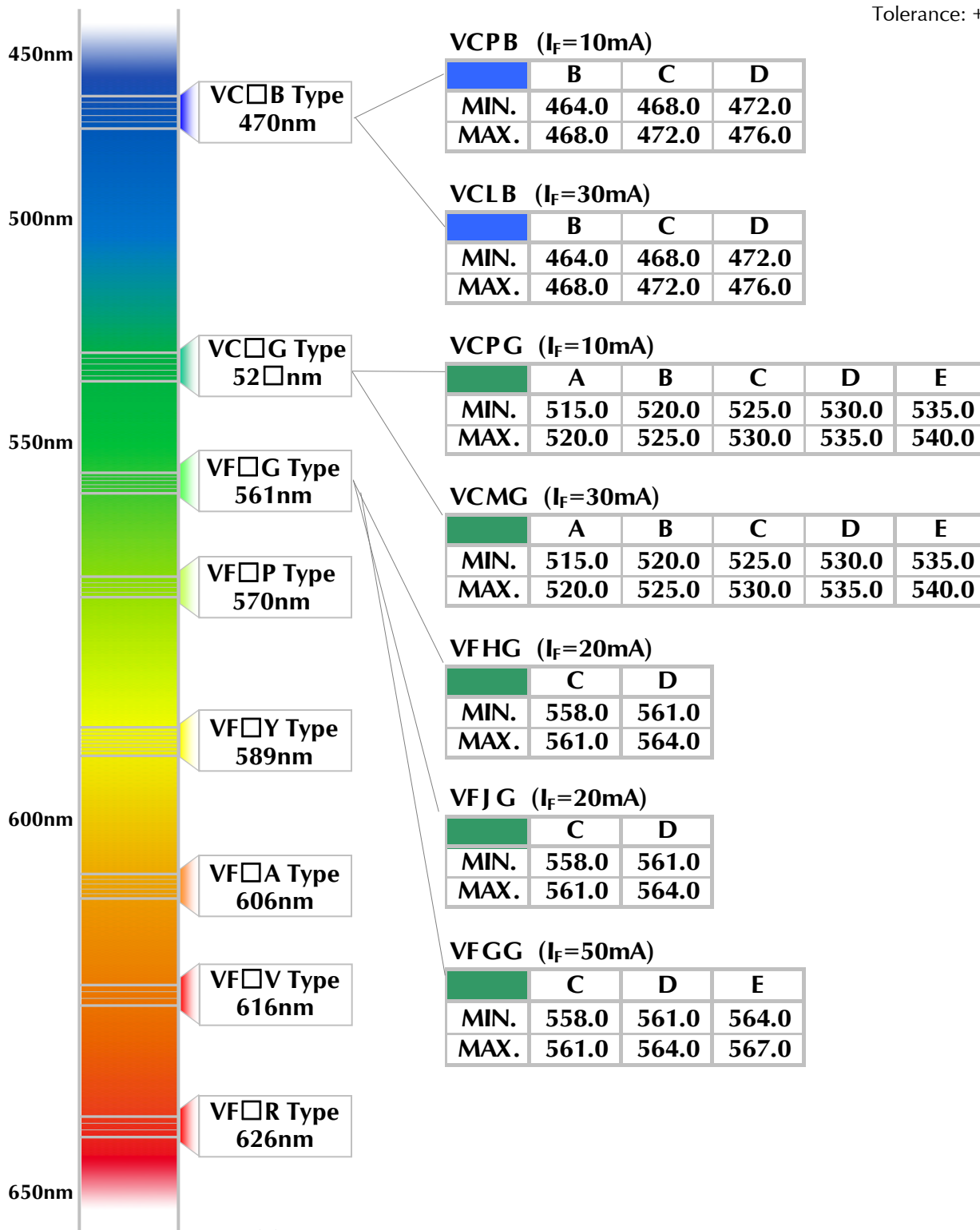

※ Please contact our sales staff concerning rank designation.

Color Tone Groups (λd)

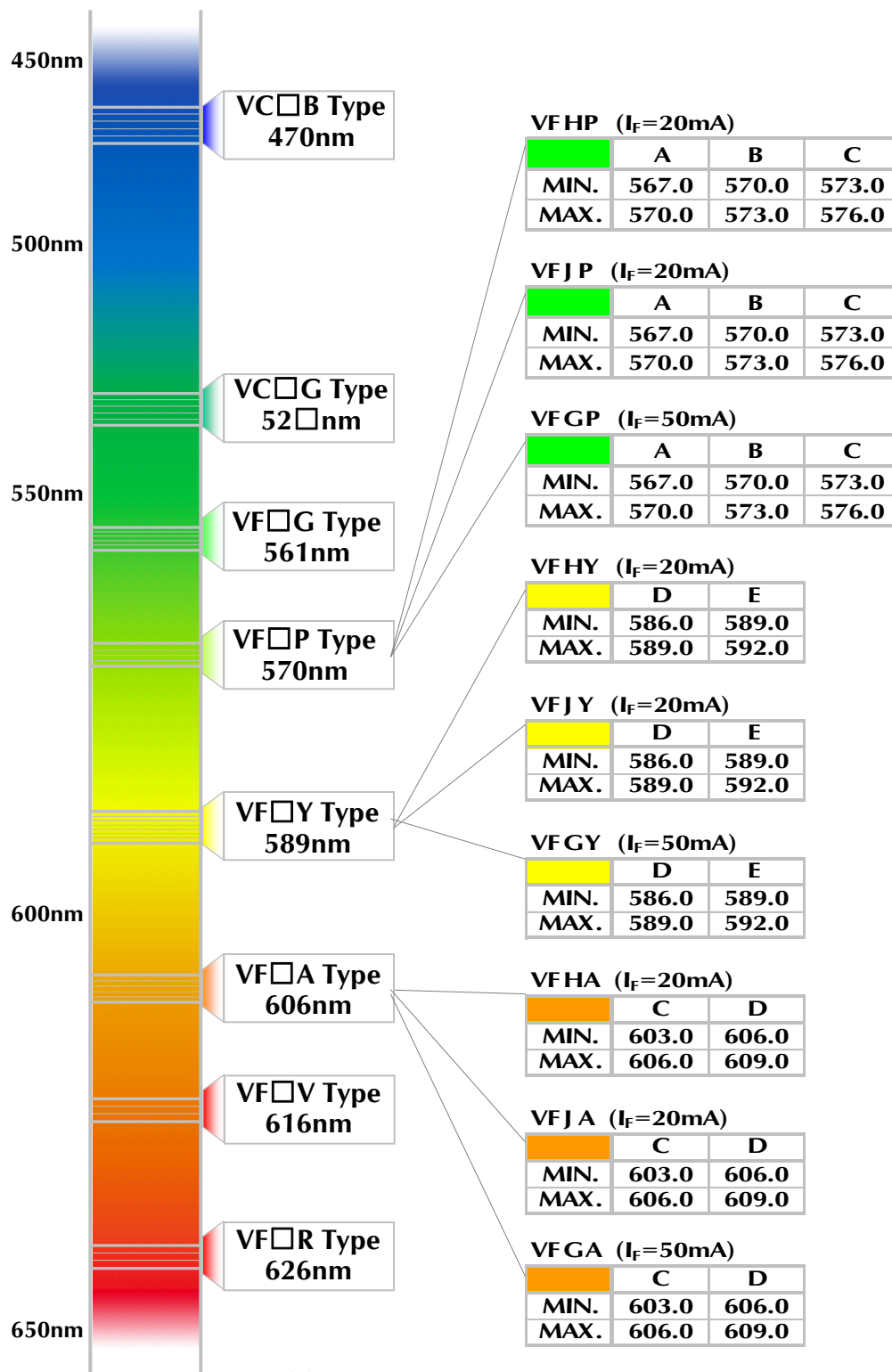

※ Please contact our sales staff concerning rank designation.

Color Tone Groups (λ_d)

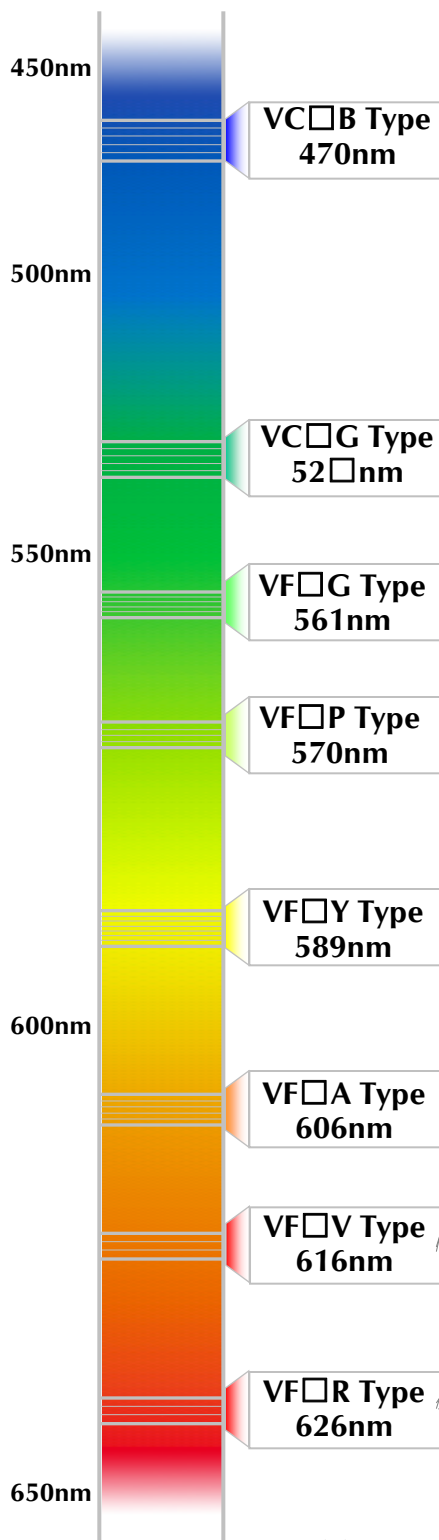
 (unit: nm)
Tolerance: +/-1nm

VFHV (I_F=20mA)

	B	C
MIN.	613.0	616.0
MAX.	616.0	619.0

VFJV (I_F=20mA)

	B	C
MIN.	613.0	616.0
MAX.	616.0	619.0

VFGV (I_F=50mA)

	B	C
MIN.	613.0	616.0
MAX.	616.0	619.0

VFHR (I_F=20mA)

	A	B
MIN.	620.0	626.0
MAX.	626.0	632.0

VFJR (I_F=20mA)

	A	B
MIN.	620.0	626.0
MAX.	626.0	632.0

VFGR (I_F=50mA)

	A	B	C
MIN.	620.0	626.0	632.0
MAX.	626.0	632.0	638.0

※ Please contact our sales staff concerning rank designation.

**Pb-free
HEAT**

1104LS Series

Single Color PLCC-2 Type
(High Reliability type, V-Series)

Package Dimensions

(Unit: mm)

MASS: (33.0)mg
Tolerance: ± 0.2

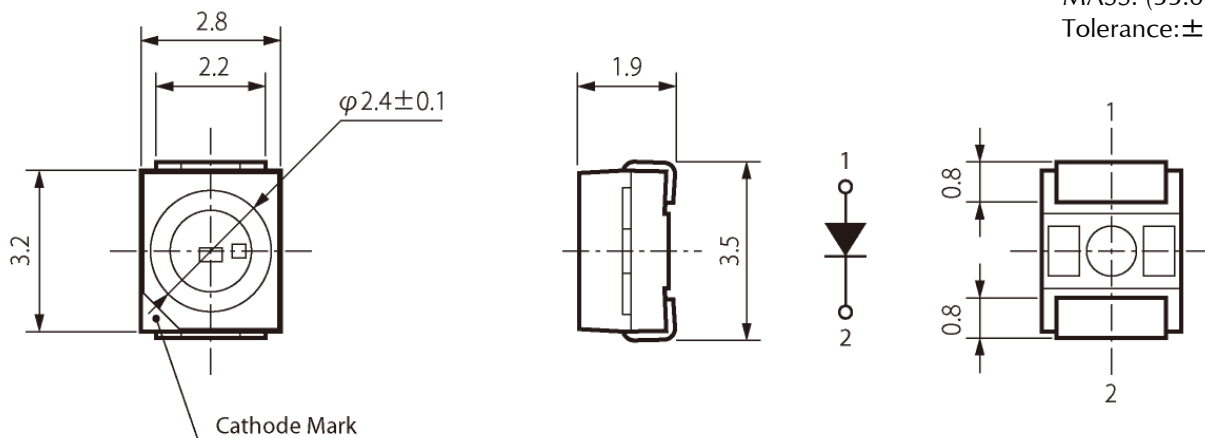

Recommended Soldering Pattern

(Unit: mm)

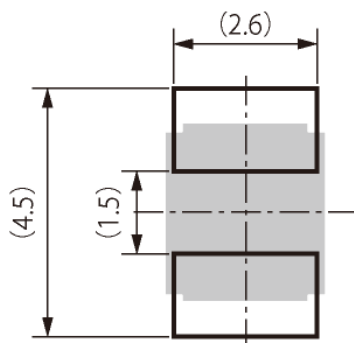

Taping Specification

(Unit: mm)

•Quantity: 2,000pcs/ reel (standard)

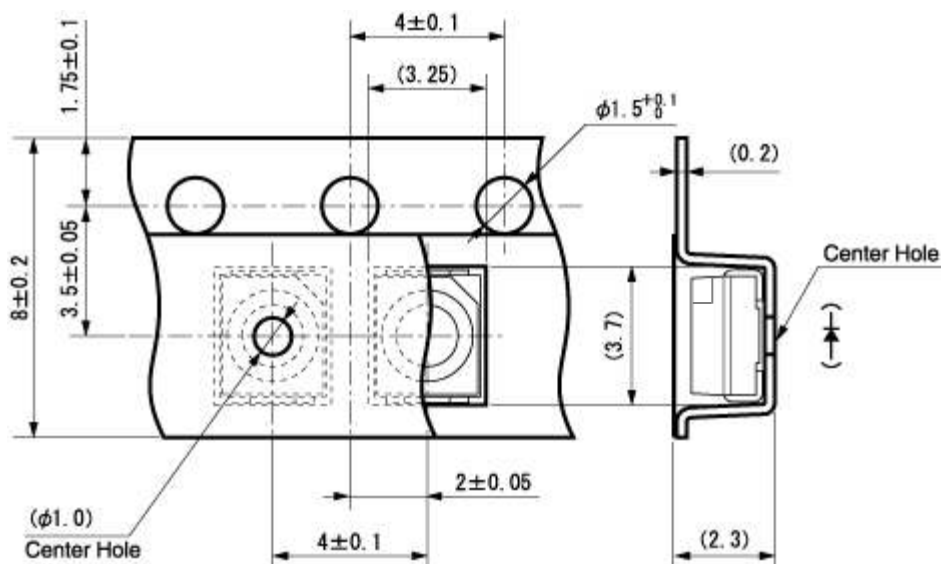

Reflow Soldering Conditions

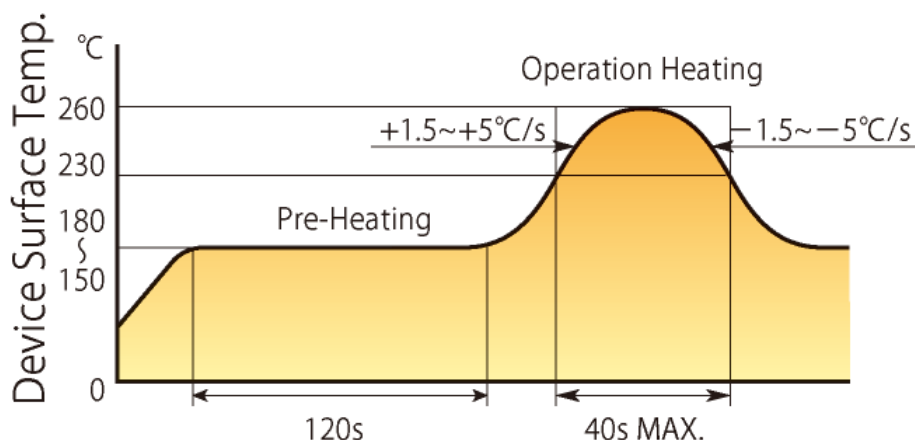

- 1) The above profile temperature gives the maximum temperature of the LED resin surface. Please set the temperature so as to avoid exceeding this range.
- 2) Total times of reflow soldering process shall be no more than 2 times. When the second reflow soldering process is performed, intervals between the first and second reflow should be short as possible (while allowing some time for the component to return to room temperature after the first reflow) in order to prevent the LED resin from absorbing moisture.
- 3) Temperature fluctuation to the LED during the pre-heating process shall be minimized.

Manual Soldering Conditions

Iron tip temp.	350 °C	(MAX.)
----------------	--------	--------

Soldering time and frequency	3 s	(MAX.)
	1 time	(MAX.)

Reliability Testing Result

Reliability Testing Result	Applicable Standard	Testing Conditions	Duration	Failure
Room Temp. Operating Life	EIAJ ED-4701/100(101)	Ta = 25°C, I _F = Maximum Rated Current	1,000 h	0/20
High Temp. Operating Life	EIAJ ED-4701/100(101)	Ta = 85°C I _F = Derating Value	1,000 h	0/20
Low Temp. Operating Life	EIAJ ED-4701/100(101)	Ta = -40°C, I _F = Maximum Rated Current	1,000 h	0/20
Wet High Temp. Operating Life	EIAJ ED-4701/100(102)	Ta = 60°C, 90%, I _F = Maximum Rated Current	1,000 h	0/20
Wet High Temp. Storage Life	EIAJ ED-4701/100(103)	Ta = 60°C, 90%	1,000 h	0/20
Thermal Shock	EIAJ ED-4701/100(105)	Ta = -40°C ~ 120°C (each 15min.)	1,000 cycles	0/20
Thermal Shock Operating	EIAJ ED-4701/100(105)	Ta = -40°C(OFF) ~ 85°C(ON) each 15min. I _F = Derating Value	1,000 cycles	0/20
High Temp. Storage Life	EIAJ ED-4701/200(201)	Ta = 120°C	1,000 h	0/20
Low Temp. Storage Life	EIAJ ED-4701/200(202)	Ta = -40°C	1,000 h	0/20
Cycled Temp. Humidity Operating Life	EIAJ ED-4701/200(203)	Ta = -30°C(2h) ~ 80°C, 95%(2h), 8h/cycle I _F = Derating Value 5min on-off	30 cycles	0/20
Resistance to Reflow Soldering	EIAJ ED-4701/300(301)	Moisture Soak : 30°C, 70%, 672h Preheat : 150°C~180°C (120s Max.) Soldering Temp. : 260°C (5s)	Twice	0/20
Electric Static Discharge (ESD) ^{※1}	EIAJ ED-4701/300(304)	C = 100pF, R2 = 1.5KΩ, ±2,000V	once each polarity	0/10
Vibration, Variable Frequency	EIAJ ED-4701/400(403)	98.1m/s ² (10G), 100 ~ 2KHz, 20min. XYZ each direction	2 h	0/10

※1 Reference test

Failure Criteria

Items	Symbols	Conditions	Failure criteria
Luminous Intensity	I _v	I _F Value of each product Luminous Intensity	Testing Min. Value < Spec. Min. Value x 0.5
Forward Voltage	V _F	I _F Value of each product Forward Voltage	Testing Max. Value ≥ Spec. Max. Value x 1.2
Reverse Current	I _R	V _R = Maximum Rated Reverse Voltage V	Testing Max. Value ≥ Spec. Max. Value x 2.5
Cosmetic Appearance	-	-	Occurrence of notable decoloration, deformation and cracking

Special Notice to Customers Using the Products and Technical Information Shown in This Data Sheet

- 1) The technical information shown in the data sheets are limited to the typical characteristics and circuit examples of the referenced products. It does not constitute the warranting of industrial property nor the granting of any license.
- 2) For the purpose of product improvement, the specifications, characteristics and technical data described in the data sheets are subject to change without prior notice. Therefore it is recommended that the most updated specifications be used in your design.
- 3) When using the products described in the data sheets, please adhere to the maximum ratings for operating voltage, heat dissipation characteristics, and other precautions for use. We are not responsible for any damage which may occur if these specifications are exceeded.
- 4) The products that have been described to this catalog are manufactured so that they will be used for the electrical instrument of the benchmark (OA equipment, telecommunications equipment, AV machine, home appliance and measuring instrument).
The application of aircrafts, space borne application, transportation equipment, medical equipment and nuclear power control equipment, etc. needs a high reliability and safety, and the breakdown and the wrong operation might influence the life or the human body. Please consult us beforehand if you plan to use our product for the usages of aircrafts, space borne application, transportation equipment, medical equipment and nuclear power control equipment, etc. except OA equipment, telecommunications equipment, AV machine, home appliance and measuring instrument.
- 5) In order to export the products or technologies described in this data sheet which are under the "Foreign Exchange and Foreign Trade Control Law," it is necessary to first obtain an export permit from the Japanese government.
- 6) No part of this data sheet may be reprinted or reproduced without prior written permission from Stanley Electric Co., Ltd.
- 7) The most updated edition of this data sheet can be obtained from the address below:
<http://www.stanley-components.com>