

P	LTR	DESCRIPTION	DATE	DWN	APVD
A		ECN-22-171085	24AUG2022	LL	DZ

NOTES:

- MATERIALS:
 PLASTICS: HIGH TEMPERATURE THERMOPLASTIC UL94V-0, COLOR: BLACK.
 SHELL: STAINLESS
 CONTACT: COPPER ALLOY
 DUST CAP: STAINLESS

- FINISH:
 TERMINAL: CONTACT AREA: SELECTED GOLD PLATING, SEE TABLE.
 SOLDER AREA: MATTE TIN PLATING 100u".
 UNDER PLATING: NICKEL PLATING 50u" MIN OVER ALL.
 SHELL: UNDER PLATING: ELECTROLESS NICKEL PLATING 50u" MIN OVERALL.
- HALOGEN REQUIREMENT MEET CODE 2: LOW BR/CL AS DEFINED IN TEC-138-702.
- TE CONNECTIVITY LOGO MARKED IN APPROXIMATE AREA SHOWN.
- PART NUMBER AND DATE CODE MARKED IN APPROXIMATE AREA SHOWN.
- TAPE AND REEL PACKAGED FOR PICK AND PLACE SMT PROCESSING.
 SEE FIGURE 1. POCKET TAPE WIDTH = 44.

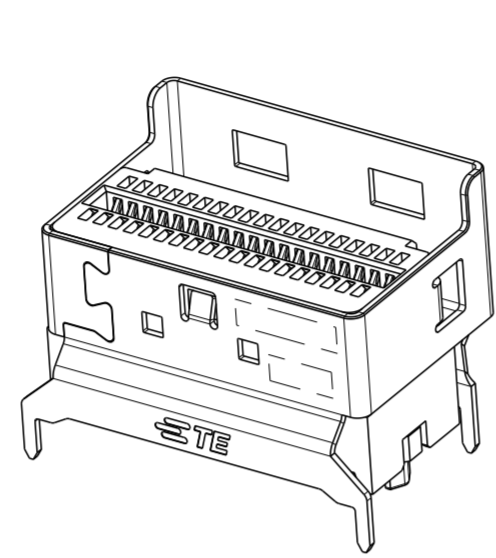
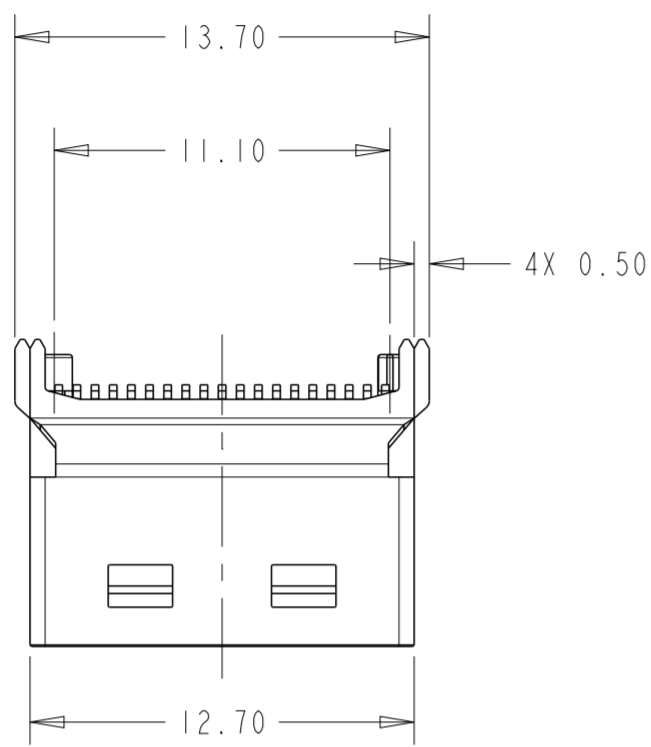

W/O DUST CAP
SCALE 4:1

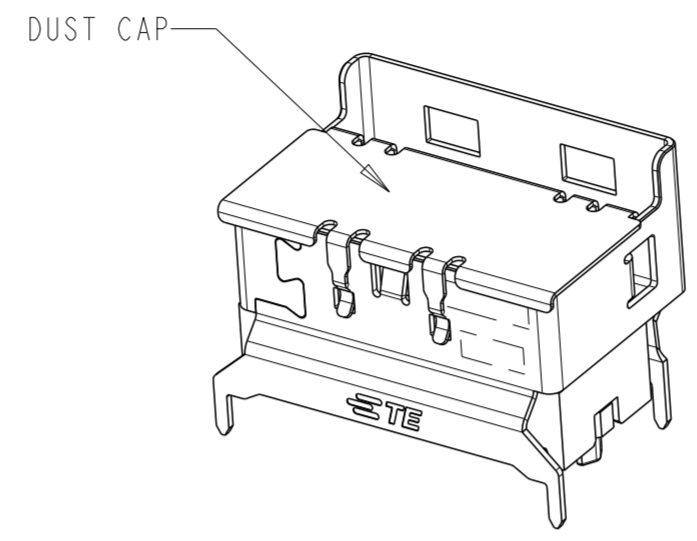

W/ DUST CAP
SCALE 4:1

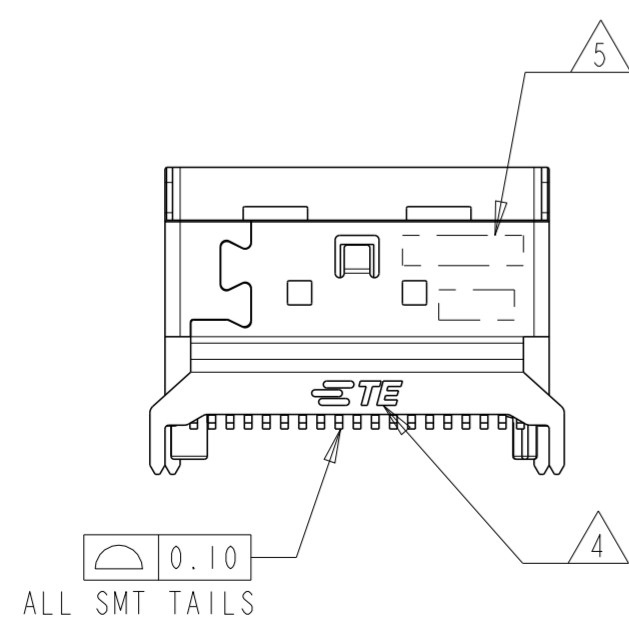
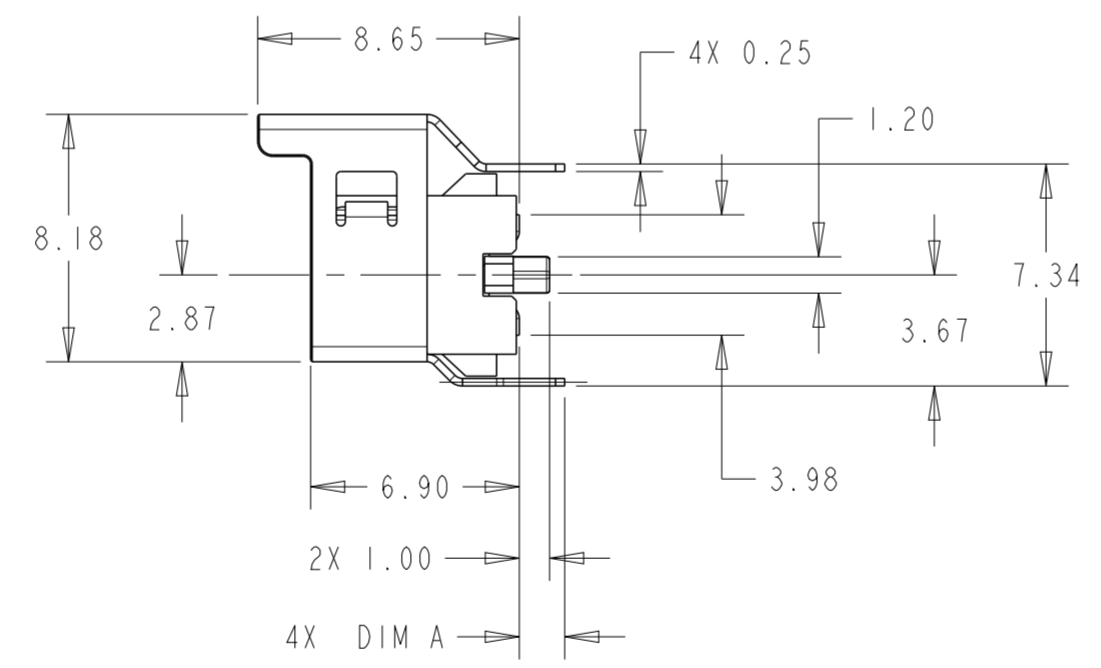
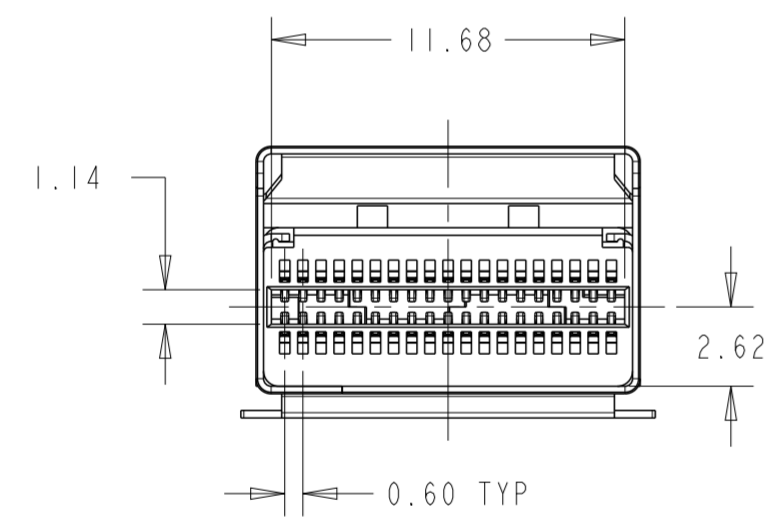

REEL DIRECTION	CARTON QUANTITY	REEL QUANTITY	CAP OPTION	CONTACT FINISH	DIM A	PART NUMBER
SEE FIGURE 1	640	160	W/O DUST CAP	30u" GOLD	4.20MM	I-2360221-8
					3.00MM	I-2360221-7
					2.20MM	I-2360221-6
				1.50MM	I-2360221-5	
				15u" GOLD	4.20MM	I-2360221-4
					3.00MM	I-2360221-3
			2.20MM		I-2360221-2	
			W/ DUST CAP	30u" GOLD	1.50MM	I-2360221-1
					1.50MM	2360221-9
					4.20MM	2360221-8
				15u" GOLD	3.00MM	2360221-7
					2.20MM	2360221-6
1.50MM	2360221-5					

THIS DRAWING IS A CONTROLLED DOCUMENT.

DIMENSIONS: mm	TOLERANCES UNLESS OTHERWISE SPECIFIED: 0 PLC ± 1 PLC ±0.35 2 PLC ±0.25 3 PLC ±0.10 4 PLC ± ANGLES ±2° FINISH	DWN LEO LI 26 JUL 2019 CHK DAVID ZHANG 26 JUL 2019 APVD DAVID ZHANG 26 JUL 2019	NAME DAVID ZHANG
MATERIAL SEE NOTE		PRODUCT SPEC 108-60134	APPLICATION SPEC 114-60031
		WEIGHT -	SIZE A2
		CUSTOMER DRAWING	CAGE CODE 00779
			DRAWING NO C-2360221
			RESTRICTED TO
			SCALE 4:1 SHEET 1 OF 3 REV A

STE TE Connectivity
LOW PROFILE SLIM SAS X4, RECEPTACLE VERTICAL CONN.

P	LTR	DESCRIPTION	DATE	DWN	APVD
-	-	SEE SHEET 1	-	-	-

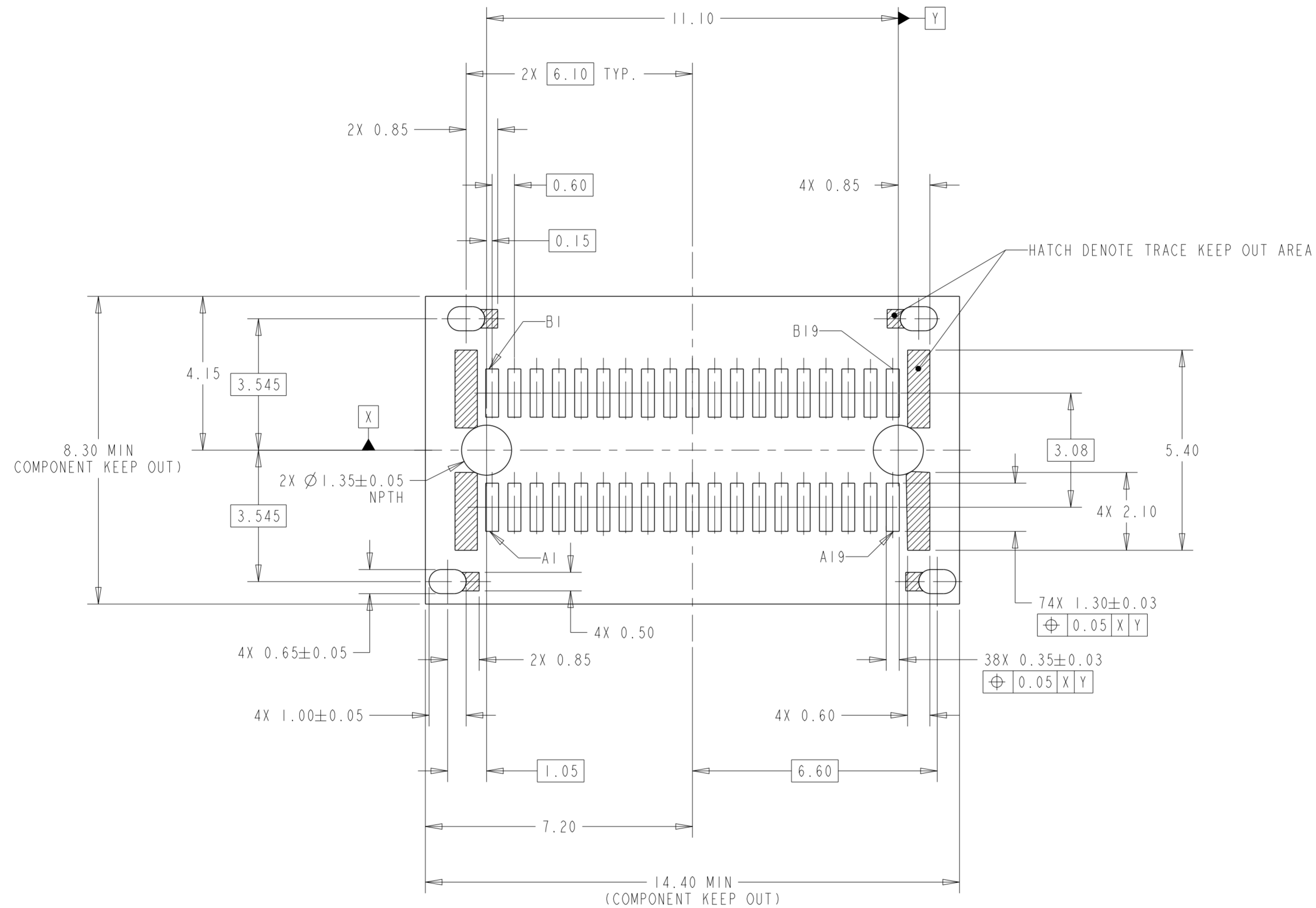

RECOMMENDED PCB LAYOUT
AND KEEP OUT AREA
TOP VIEW
TOLERANCE: ±0.05
SCALE 10:1

THIS DRAWING IS A CONTROLLED DOCUMENT.		DWN LEO LI 26 JUL 2019	 TE Connectivity	
DIMENSIONS: mm		CHK DAVID ZHANG 26 JUL 2019		
TOLERANCES UNLESS OTHERWISE SPECIFIED:		APVD DAVID ZHANG 26 JUL 2019	NAME LOW PROFILE SLIM SAS X4, RECEPTACLE VERTICAL CONN.	
0 PLC ± 1 PLC ±0.35 2 PLC ±0.25 3 PLC ±0.10 4 PLC ± ANGLES ±2° FINISH		PRODUCT SPEC 108-60134	RESTRICTED TO	
MATERIAL SEE NOTE		APPLICATION SPEC 114-60031	SIZE A2	CAGE CODE 00779
		WEIGHT -	DRAWING NO C-2360221	SCALE 4:1
		CUSTOMER DRAWING	SHEET 2 OF 3	REV A

P	LTR	DESCRIPTION	DATE	DWN	APVD
-	-	SEE SHEET 1	-	-	-

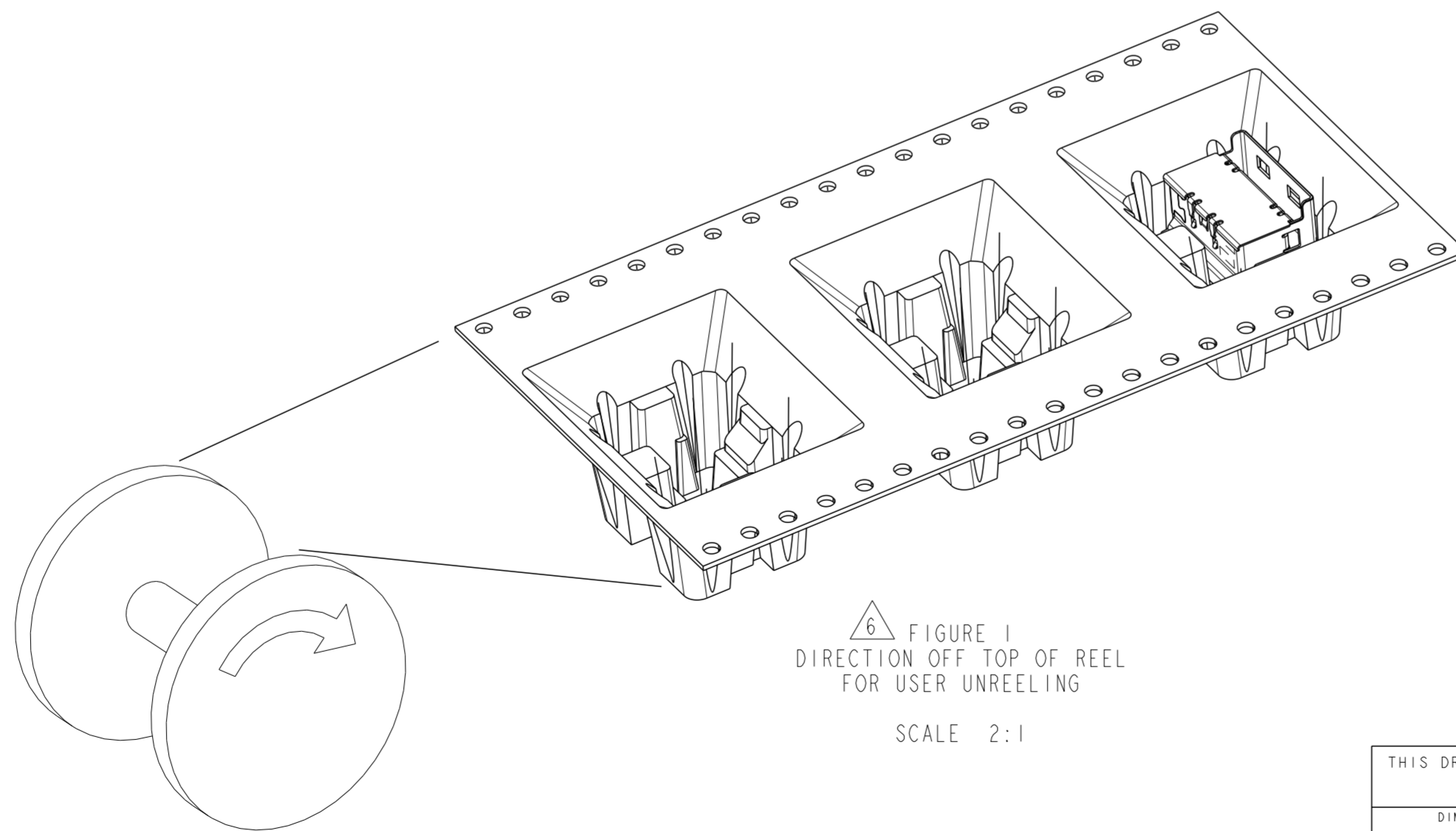
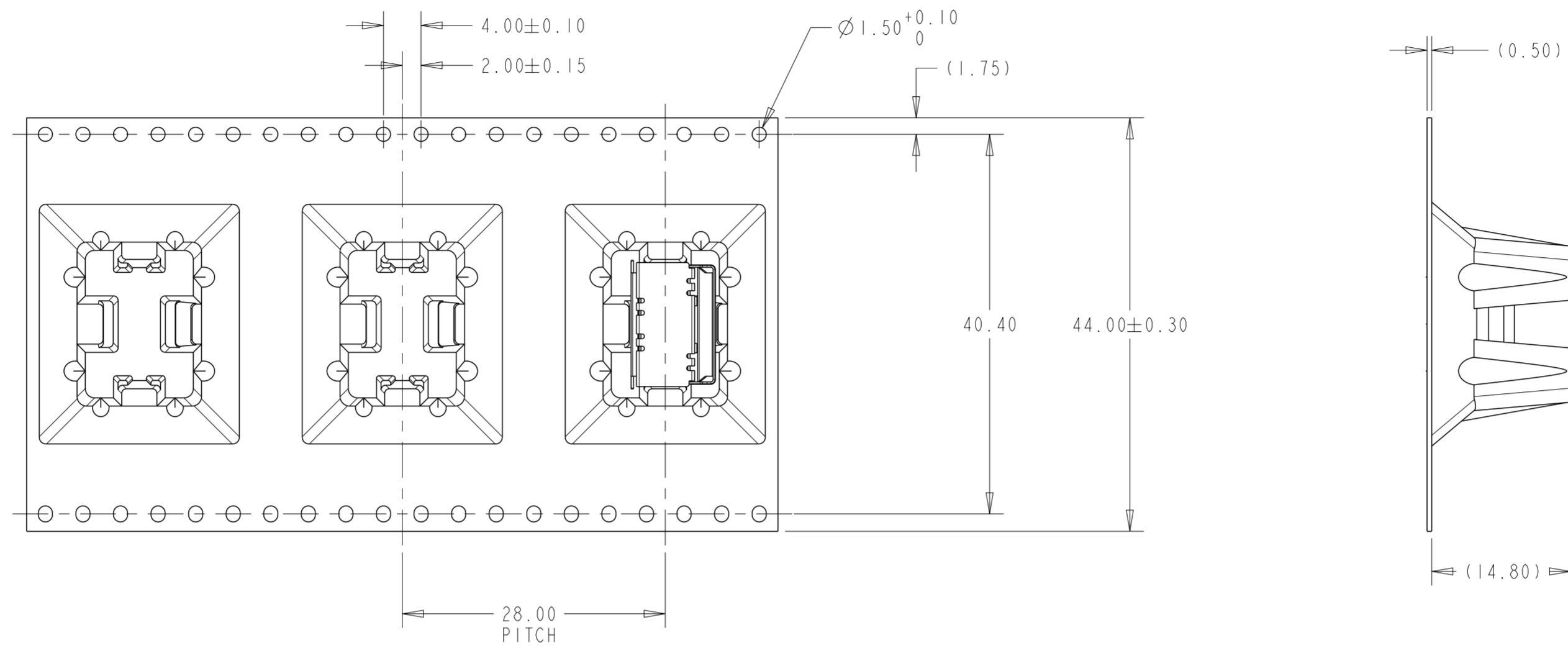

6 FIGURE 1
DIRECTION OFF TOP OF REEL
FOR USER UNREELING
SCALE 2:1

THIS DRAWING IS A CONTROLLED DOCUMENT.		DWN LEO LI 26 JUL 2019	TE Connectivity	
DIMENSIONS: mm		CHK DAVID ZHANG 26 JUL 2019		
TOLERANCES UNLESS OTHERWISE SPECIFIED:		APVD DAVID ZHANG 26 JUL 2019	NAME LOW PROFILE SLIM SAS X4, RECEPTACLE VERTICAL CONN.	
0 PLC ±		PRODUCT SPEC 108-60134	SIZE A2	
1 PLC ±0.35		APPLICATION SPEC 114-60031	CAGE CODE 00779	DRAWING NO C-2360221
2 PLC ±0.25		WEIGHT -	RESTRICTED TO	
3 PLC ±0.10		CUSTOMER DRAWING	SCALE 4:1	SHEET 3 OF 3
4 PLC ±			REV A	
ANGLES ±2°				
FINISH				
MATERIAL SEE NOTE				