

OPTION C

- NOTES:
 1. MATERIAL:
 HOUSING: POLYESTER(PBT), GLASS FILLED, UL94 V-0,
 COLOR: BLACK
 TERMINAL: PHOSPHOR BRONZE
 2. FINISH:
 30 GOLD: 0.76 MICROMETERS/30 MICROINCHES MINIMUM GOLD IN
 1.91 MICROMETERS/75 MICROINCHES MINIMUM TIN
 OVER NICKEL UNDERPLATE OVERALL
 3. TO BE USED WITH 22 AWG STRANDED WIRE WITH (1.35)/.053
 DIAMETER MAXIMUM INSULATION
 4. SEE TABLE FOR AVAILABLE CIRCUIT SIZES
 5. STANDARD PACKAGING PER PK-70873-0001. OPTIONAL PACKAGING
 MAY BE AVAILABLE, REQUEST DRAWING PK-70400
 6. PARTS STACKABLE END TO END ON (2.54)/.100 CENTERS
 7. PRODUCT SPECIFICATION: PS-70400
 8. SEE DRAWING SDA-70400-**** (SHEET 3) FOR OPTIONAL
 HOUSING DETAILS
 9. 4 CIRCUIT SHOWN. 3-25 CIRCUITS HAVE 2 RIBS
 10. TO MATE WITH MOLEX PART NUMBERS: A-70374-****,
 A-70376-****, A-70390-****, A-70392-****,
 A-70544-****, A-70554-****, A-70542-****,
 A-70552-****, A-70546-****, A-70556-****,
 11. 2 CIRCUIT ASSEMBLIES SUPPLIED AS GROUPED PAIRS

CKT. SIZE	A	B	EDP. NO.
2	(2.54) .100	(5.05) .199	14-56-8020
3	(5.08) .200	(7.59) .299	14-56-8030
4	(7.62) .300	(10.13) .399	14-56-8040
5	(10.16) .400	(12.67) .499	14-56-8050
6	(12.70) .500	(15.21) .599	14-56-8060
7	(15.24) .600	(17.75) .699	14-56-8070
8	(17.78) .700	(20.29) .799	14-56-8080
9	(20.32) .800	(22.83) .899	14-56-8090
10	(22.86) .900	(25.37) .999	14-56-8100
11	(25.54) 1.000	(27.91) 1.099	14-56-8110
12	(27.94) 1.100	(30.45) 1.199	14-56-8120
13	(30.48) 1.200	(32.99) 1.299	14-56-8130
14	(33.02) 1.300	(35.53) 1.399	14-56-8140
15	(35.56) 1.400	(38.07) 1.499	14-56-8150
16	(38.01) 1.500	(40.61) 1.599	14-56-8160
17	(40.64) 1.600	(43.15) 1.699	14-56-8170
18	(43.18) 1.700	(45.69) 1.799	14-56-8180
19	(45.72) 1.800	(48.23) 1.899	14-56-8190
20	(48.26) 1.900	(50.77) 1.999	14-56-8200
21	(50.80) 2.000	(53.31) 2.099	14-56-8210
22	(53.34) 2.100	(55.85) 2.199	14-56-8220
23	(55.88) 2.200	(58.39) 2.299	14-56-8230
24	(58.42) 2.300	(60.93) 2.399	14-56-8240
25	(60.96) 2.400	(63.47) 2.499	14-56-8250

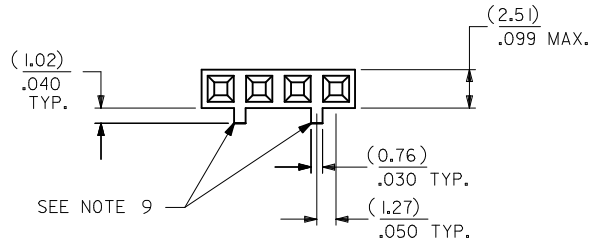

SECTION C-C

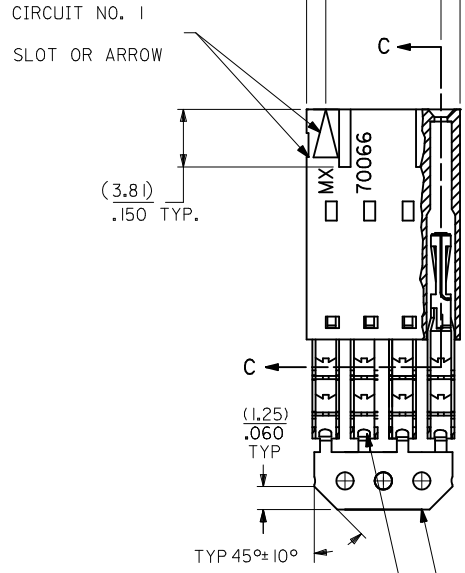
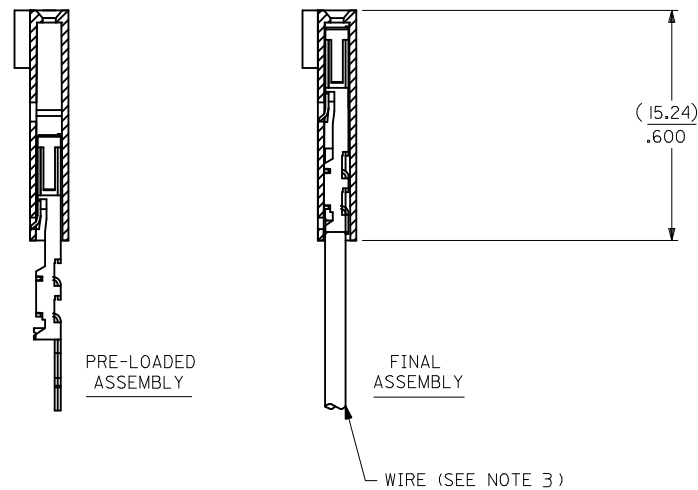

I.D. SLOT CODE TO WIRE GAUGE CHART	
I.D. SLOT CODE	WIRE GAUGE
D	22 AWG.

PLATING CODE (STRIPE ON CARRIER STRIP)	
PLATING	COLOR
30 GOLD	RED

REMOVE ENG NO. EC NO: UCP2011-110 DRW:MSI BARRA 2010/10/19 CHKD:J MORGAN 2010/10/19 APPR:SMILLER 2010/11/24	QUALITY SYMBOLS ▽=0 ▽=0 ▽=0	GENERAL TOLERANCES (UNLESS SPECIFIED) mm INCH 4 PLACES ± --- ± --- 3 PLACES ± --- ± .010 2 PLACES ± 0.25 ± .014 1 PLACE ± 0.35 ± --- ANGULAR ±1/2°	DIMENSION STYLE MM/IN DRAWN BY DATE MSI BARRA 2010/10/20 CHECKED BY DATE WAZ 1987/10/26 APPROVED BY DATE SMILLER 2010/11/24	SCALE DESIGN UNITS INCH THIRD ANGLE PROJECTION	TITLE ASSEMBLY, SL CONNECTOR SINGLE ROW 2.54/.100 GRID
		DRAFT WHERE APPLICABLE MUST REMAIN WITHIN DIMENSIONS	MATERIAL NO. SEE TABLE	DOCUMENT NO. SDA-70400-3385-3408	SHEET NO. 1 OF 1

THIS DRAWING CONTAINS INFORMATION THAT IS PROPRIETARY TO MOLEX INCORPORATED AND SHOULD NOT BE USED WITHOUT WRITTEN PERMISSION