

## 2.4GHz High Power 802.11n WLAN Linear Power Amplifier

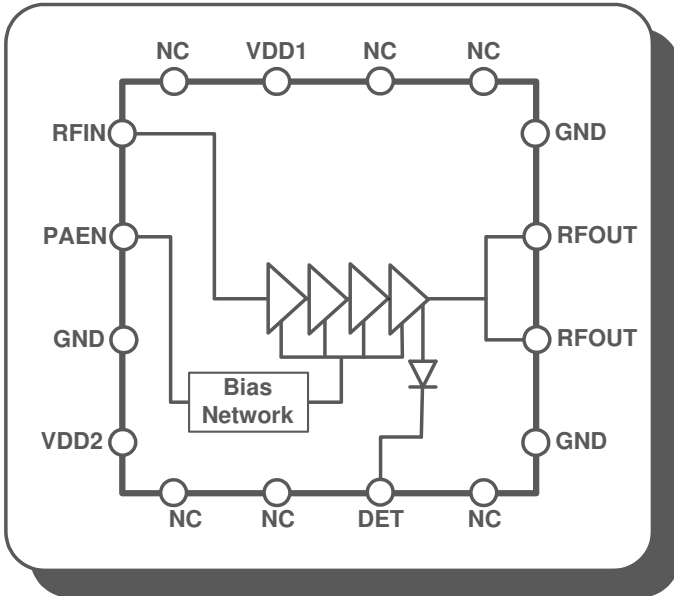

### DESCRIPTION

The RFX240 is high power, high linearity power amplifier implemented in CMOS process. The device is optimized to provide all functionality of transmit power amplification for IEEE 802.11b/g/n applications in the 2.4GHz frequency range.

The RFX240 provides 30dB gain and up to +26dBm linear output power with low EVM of <3% for 802.11n MCS7 HT40 signals. It has CMOS logic control, on-chip input impedance matching, as well as integrated RF decoupling for the power supply.

The RFX240 is assembled in a compact 3.0x3.0mm 16L-QFN package. It requires minimal external components to greatly simplify RF front-end implementation.

### APPLICATIONS

- ▶ High Power WLAN AP/Router
- ▶ Set-Top Box (STB)/ Home Gateway
- ▶ Enterprise/SOHO Wi-Fi Networks
- ▶ Outdoor WLAN Hotspots
- ▶ Wi-Fi Extenders
- ▶ Wi-Fi Dongles

### FEATURES

- ▶ 2.4GHz, Single Chip, Single-Die RF Power Amplifier
- ▶ 2.4GHz High Power PA with Low-Pass Harmonic Filter
- ▶ 802.11n MCS7 HT40 Support with <3% EVM up to +26dBm at 5V
- ▶ High Gain of 30dB
- ▶ High Transmit Signal Linearity Meeting Standards for OFDM and CCK modulation
- ▶ Integrated Power Detector for Transmit Power Monitor and Control
- ▶ Compatible with Low Voltage (1.2V) CMOS Control Logic or levels up to VDD
- ▶ ESD Protection Circuitry on All Ports
- ▶ DC Decoupled RF Ports
- ▶ Internal RF Decoupling on All VDD Bias Pins
- ▶ Very Low DC Power Consumption
- ▶ Full On-chip Matching and Decoupling Circuitry
- ▶ Minimal External Components Required
- ▶ 50-Ohm Input / Output Matching
- ▶ 3 x 3 x 0.55mm Small Outline QFN-16 Package with Exposed Ground Pad

**DEVICE PIN-OUT DIAGRAM**

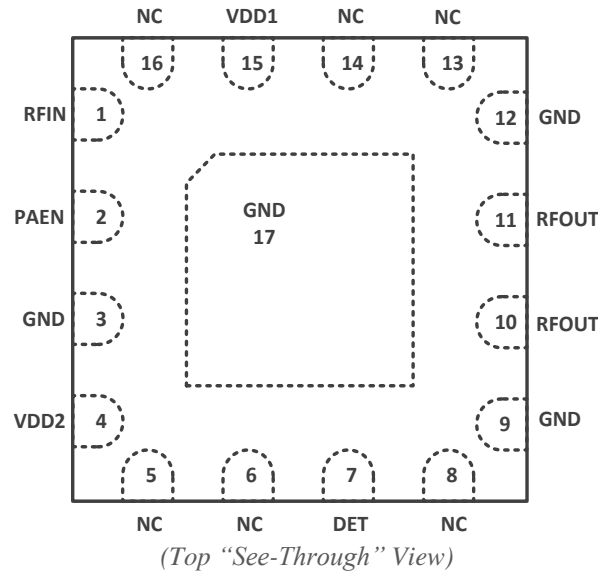

**DEVICE PIN-OUT ASSIGNMENT**

Pin Number	Pin Name	Description
1	RFIN	RF Input Signal to the PA – DC Internally Shorted to GND
2	PAEN	CMOS Logic Control to Enable the PA
3, 9, 12, 17	GND	Ground – Must be Connected to Ground in the Application Circuit
4, 15	VDD1, VDD2	DC Supply Voltage
7	DET	PA Power Detector Voltage Output
5, 6, 8, 13, 14, 16	NC	Not Connected Internally
10, 11	RFOUT	RF Output Signal from the PA

**CONTROL LOGIC TRUTH TABLE**

PAEN	Mode of Operation
0	PA is OFF; Device in Standby
1	PA is Enabled

*Note:* "1" denotes high voltage stage (>1.2V) at PAEN Control Pin;  
"0" denotes low voltage stage (<0.3V) at PAEN Control Pin

**ABSOLUTE MAXIMUM RATINGS**

Parameters	Min	Max	Units	Conditions
DC VCC Voltage Supply	0	6.0	V	All VCC Pins
DC Control Pin Voltage	0	3.6	V	All Control Pins
DC VCC Current Consumption		800	mA	VCC Pins when PA is Enabled
TX RF Input Power		+10	dBm	
ANT RF Input Power		+10	dBm	
Junction Temperature		150	°C	
Storage Ambient Temperature	-50	+150	°C	Appropriate care required according to JEDEC Standards
Operating Ambient Temperature	-40	+85	°C	All Operating Modes
ESD Voltage (HBM)	1000		V	Human Body Model

*Note: Sustained operation at or above the Absolute Maximum Ratings for any single or combinations of the above parameters may result in permanent damage to the device and is not recommended. All Maximum RF Input Power Ratings assume 50-Ohm terminal impedance.*

**GENERAL CHARACTERISTICS**

Parameters	Min	Typ	Max	Units	Conditions
Operating Frequency	2.4		2.5	GHz	
DC VDD Voltage Supply (Note 1)	3.6	5.0	5.5	V	All VDD Pins
Control Voltage “High”	1.2		3.6	V	
Control Voltage “Low”		0	0.3	V	
Control Pin Current Consumption		1		μA	
DC Shutdown Current		5		μA	
PA Turn On/Off Time			1	μsec	
$\theta_{ja}$ (Note 2)		25		°C/W	
Input Single-Ended Impedance		50		Ω	

*Note 1 – For normal operation of the RFX240, VDD must be continuously applied to all VDD supply pins.*

*Note 2 – For operation above +85 °C, use the  $\theta_{ja}$  as guidance for system design to assure the junction temperature will not exceed the maximum of +150 °C.*

**TRANSMIT CHARACTERISTICS**

(VDD = 5.0V, PAEN = HI, T<sub>A</sub> = +25°C, UNLESS OTHERWISE SPECIFIED, AS MEASURED ON THE RFX240 EVALUATION BOARD, DE-EMBEDDED TO THE DEVICE)

Parameters	Min	Typ	Max	Units	Conditions
Operating Frequency Band	2.4		2.5	GHz	All RF Pins Terminated by 50 Ohms
Output P1dB		+32		dBm	CW
Linear Output Power (802.11n)		+25.5		dBm	802.11n MCS7 HT20 <30dB DEVM
Linear Output Power (802.11b)		+26		dBm	1Mbps CCK Mask Compliance
Small-Signal Gain		30		dB	CW
Second Harmonic		-70		dBc	P <sub>OUT</sub> = +29dBm, CW
Third Harmonic		-70		dBc	P <sub>OUT</sub> = +29dBm, CW
Input Return Loss		-15		dB	At RFIN Pin
Output Return Loss		-5		dB	At RFOUT Pins
TX Quiescent Current		210		mA	No RF Input Signal
TX Linear Current		420		mA	P <sub>OUT</sub> = +26dBm, 11n MCS7 HT20
Power Detector Voltage Output		0.2-0.9		V	5dBm to +27dBm, 10KΩ Load
Load VSWR for Stability (CW, Fix Pin for P <sub>OUT</sub> = +29dBm with 50Ω Load)	4:1	6:1		N/A	All non-harmonically related spurs less than -43 dBm/MHz
Load VSWR for Ruggedness (CW, Fix Pin for P <sub>OUT</sub> = +29dBm with 50Ω Load)	8:1	10:1		N/A	No damage

**PACKAGE DIMENSIONS**

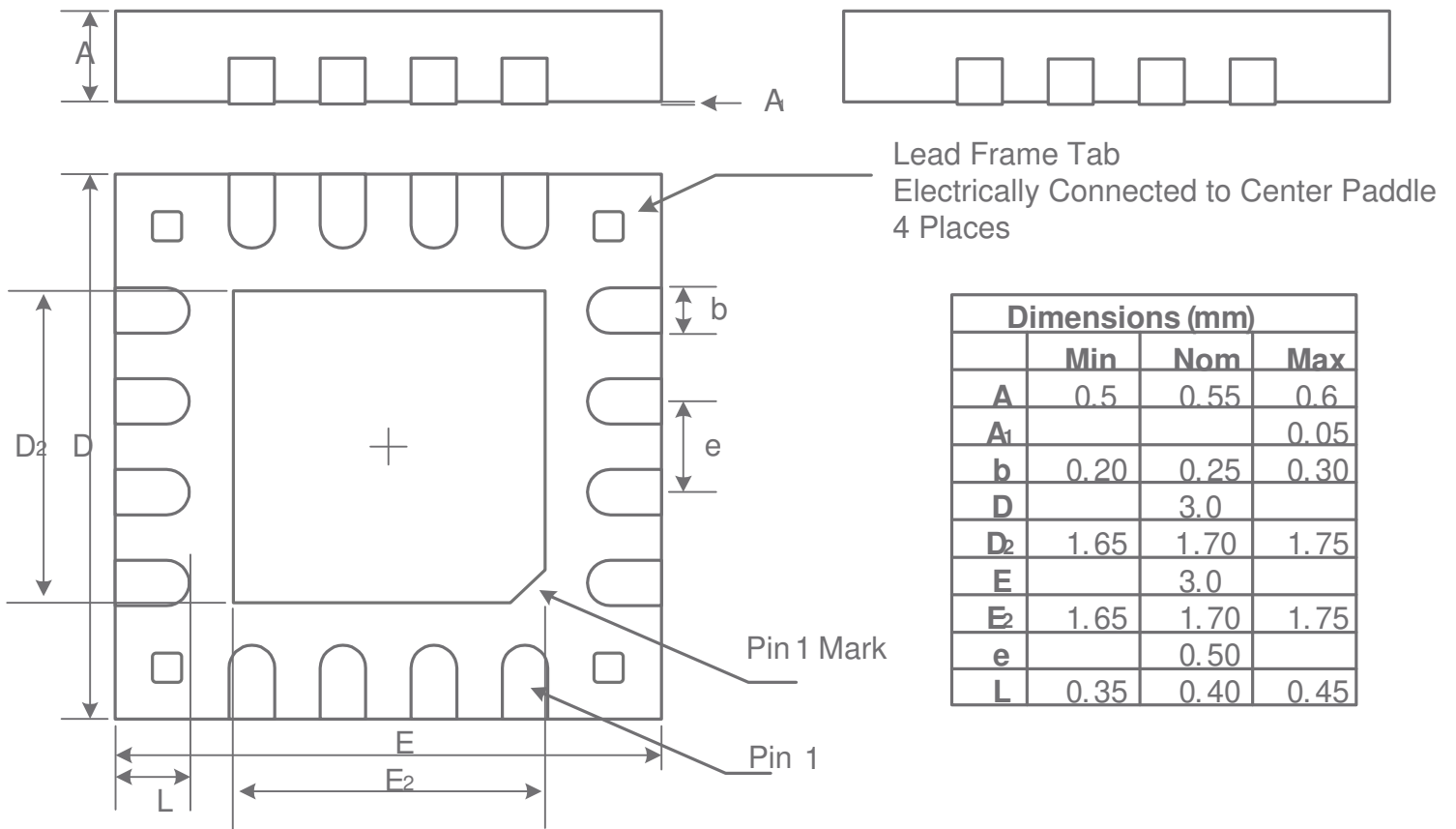

**PACKAGE MARKING**

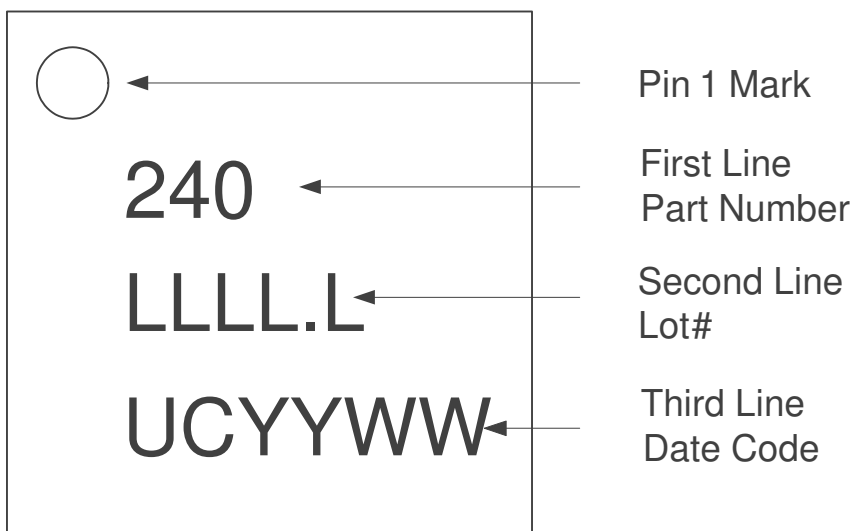

**TAPE AND REEL INFORMATION:**

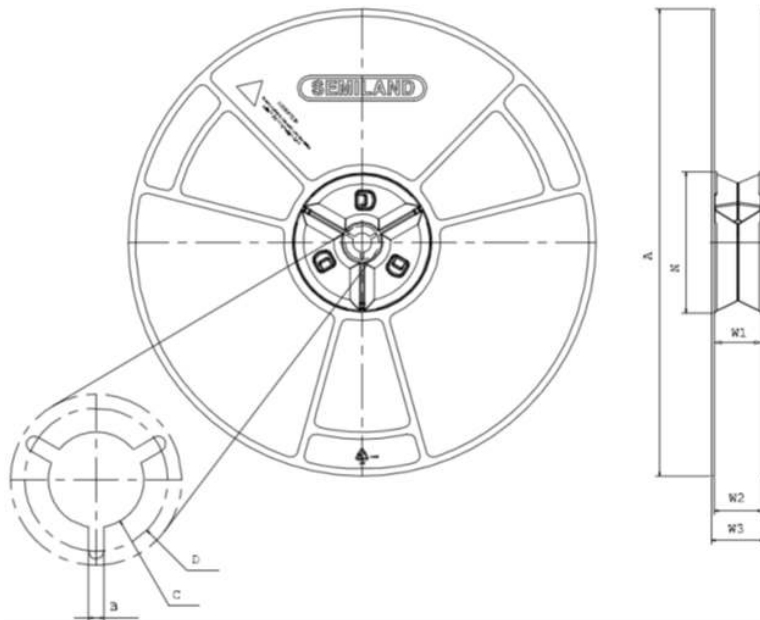
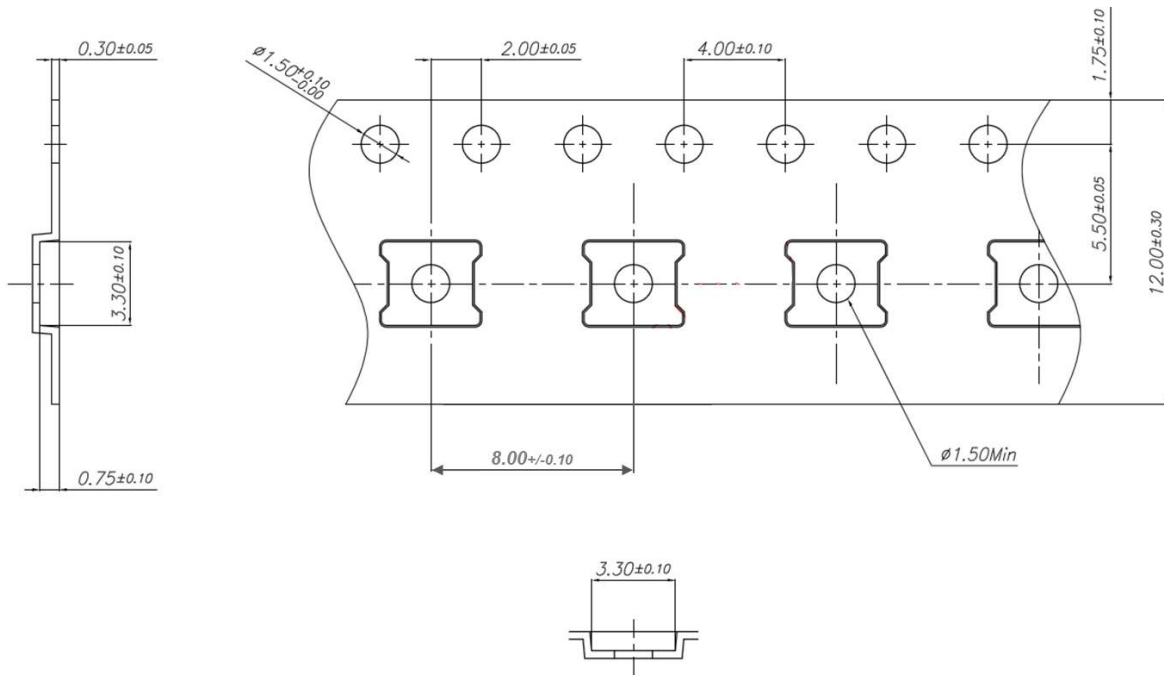

Size	12mm
A	330 <sup>+0.2</sup> <sub>-2.0</sub>
B	1.5min
C	13.0 <sup>+0.5</sup> <sub>-0.2</sub>
D	20.2min
N	100 <sup>+2.0</sup> <sub>-0.0</sub>
W1	12.4 <sup>+3.0</sup> <sub>-0.0</sub>
W2	12.4 <sup>+3.0</sup> <sub>-0.0</sub>
W3	16.4 <sup>+2.0</sup> <sub>-2.0</sub>
PART#	SRL-12134H