

3-TERMINAL 1A ADJUSTABLE VOLTAGE REGULATOR

Description

The AZ317 is an adjustable three-terminal positive voltage regulator with a very low dropout of 1.2V at 1A output current. Using 2 external resistors, the AZ317 can provide an adjustable output voltage down to 1.25V.

The AZ317 includes a circuit of trimmed bandgap reference to assure output voltage accuracy to be within 1%. It also provides current limiting and thermal shutdown. The current limit is trimmed to ensure specified output current and controlled short-circuit current. The On-chip thermal limiting provides protection against any combination of overload and ambient temperature that would create excessive junction temperature.

The AZ317 is available in the standard SOT223, TO220-3, TO252-2 (1) and TO252-2 (3) power packages.

Features

- Typical 1% Output Voltage Tolerance
- Typical 0.01%/V Line Regulation
- Typical 0.2% Load Regulation
- Very Low Dropout Voltage: 1.2V at 1A Output Current
- Trimmed Current Limit
- On-chip Thermal Protection
- Operation Junction Temperature: 0 to +125°C
- Lead-Free Packages: SOT223, TO220-3, TO252-2 (1) and TO252-2 (3)
 - **Totally Lead-Free; RoHS Compliant (Notes 1 & 2)**
- Lead-Free Packages, Available in "Green" Molding Compound: SOT223
 - **Totally Lead-Free & Fully RoHS Compliant (Notes 1 & 2)**
 - **Halogen and Antimony Free. "Green" Device (Note 3)**

Applications

- PC Motherboard
- LCD Monitor
- Graphic Card
- DVD Player
- Network Interface Card/Switch
- Telecom Equipment
- Printer and other Peripheral Equipment

- Notes:
1. No purposely added lead. Fully EU Directive 2002/95/EC (RoHS), 2011/65/EU (RoHS 2) & 2015/863/EU (RoHS 3) compliant.
 2. See <https://www.diodes.com/quality/lead-free/> for more information about Diodes Incorporated's definitions of Halogen- and Antimony-free, "Green" and Lead-free.
 3. Halogen- and Antimony-free "Green" products are defined as those which contain <900ppm bromine, <900ppm chlorine (<1500ppm total Br + Cl) and <1000ppm antimony compounds.

Pin Assignments

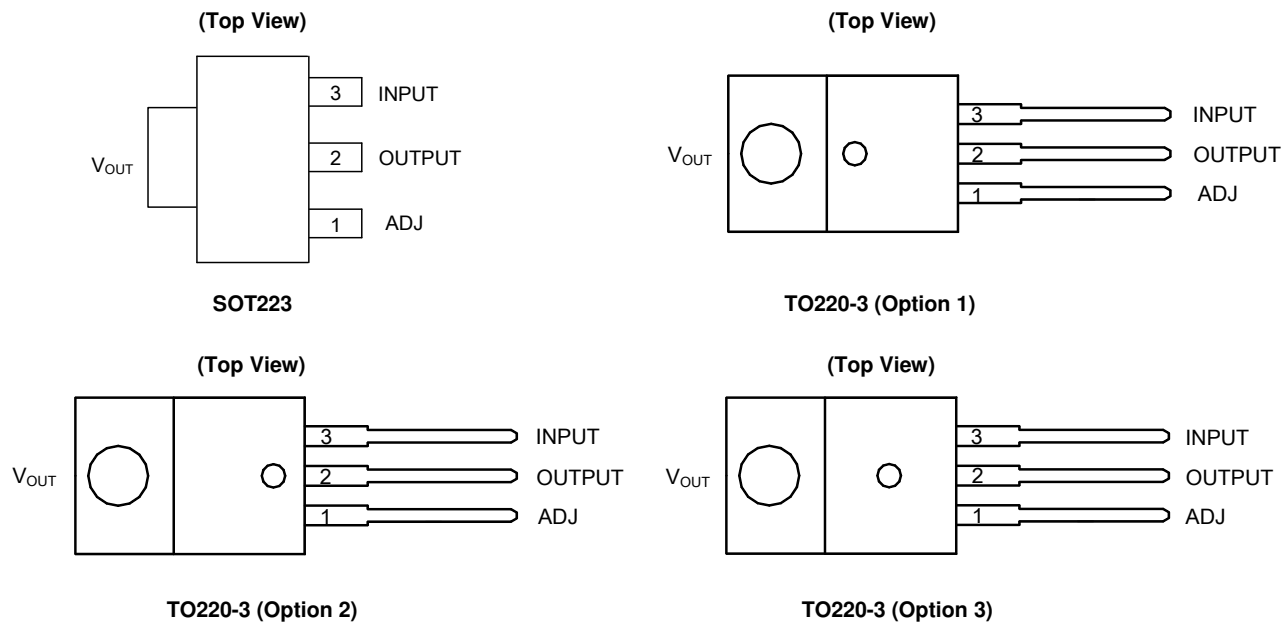

Pin Assignments (Cont.)

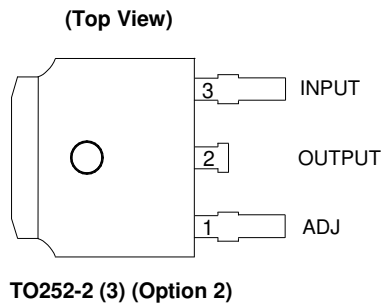
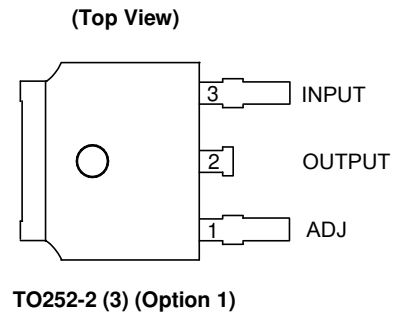
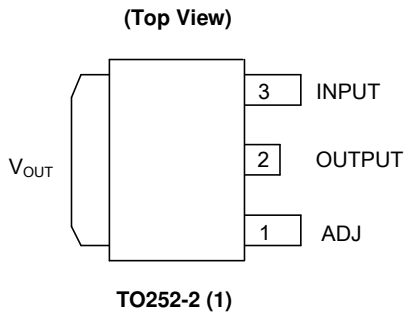

Typical Applications Circuit

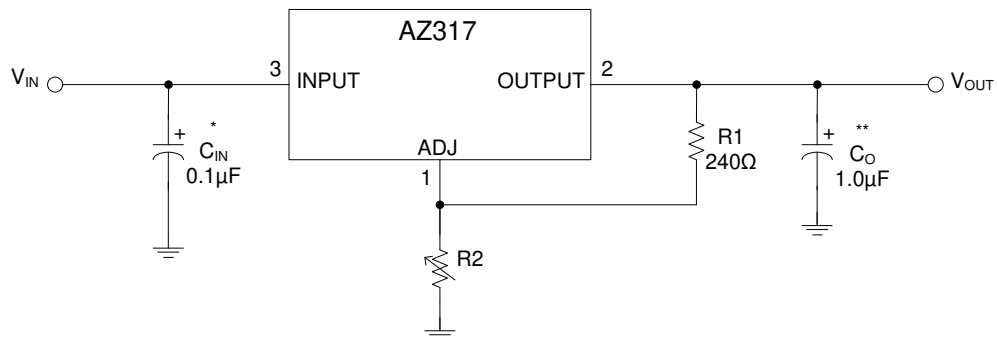

* = C_{IN} is required if the regulator is located near power supply filter.

**= C_O is needed for stability and it improves transient response.

$$V_{OUT} = V_{REF} \times (1 + R_2/R_1) + I_{ADJ} \times R_2$$

Since I_{ADJ} is controlled to less than 100µA, the error associated with this term is negligible in most applications.

Functional Block Diagram

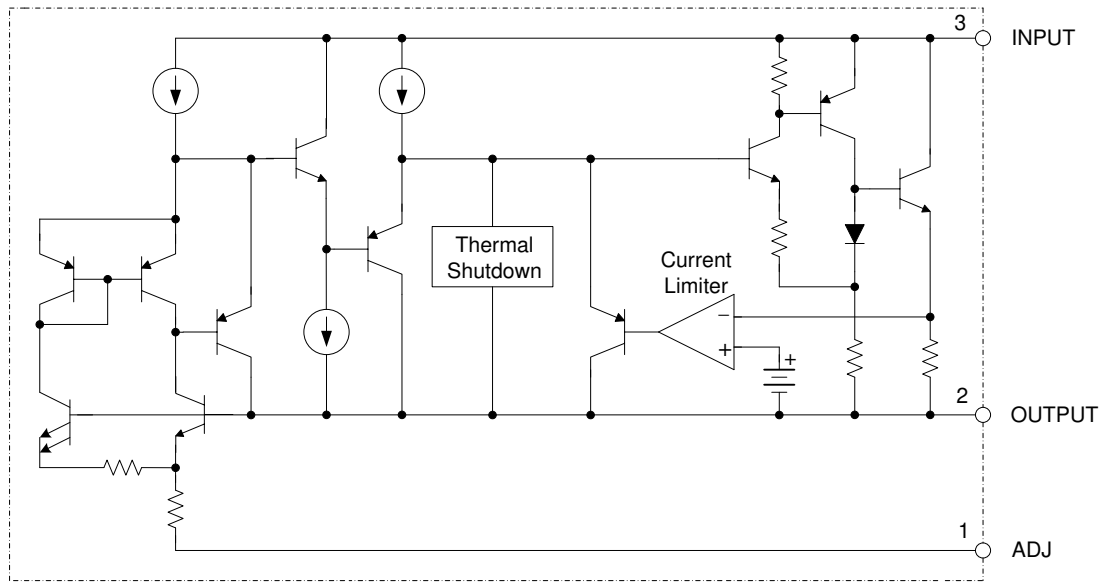

Absolute Maximum Ratings (Note 4)

Symbol	Parameter	Value	Unit
V_{IN}	Input Voltage	20	V
T_J	Maximum Junction Temperature	+150	°C
T_S	Storage Temperature	-65 to +150	°C
T_{LEAD}	Lead Temperature (Soldering, 10sec)	+300	°C
ESD	ESD (Human Body Model)	4000	V

Note 4: Stresses greater than those listed under "Absolute Maximum Ratings" may cause permanent damage to the device. These are stress ratings only, and functional operation of the device at these or any other conditions beyond those indicated under "Recommended Operating Conditions" is not implied. Exposure to "Absolute Maximum Ratings" for extended periods may affect device reliability.

Recommended Operating Conditions

Symbol	Parameter	Min	Max	Unit
V_{IN}	Input Voltage	$V_{OUT}+2$	15	V
T_J	Operating Junction Temperature Range	0	+125	°C

Electrical Characteristics (Typicals and limits apply for $T_J = +25^\circ\text{C}$, $P \leq$ Maximum Power Dissipation unless otherwise specified. Note 5)

Symbol	Parameter	Conditions	Min	Typ	Max	Unit
V_{REF}	Reference Voltage	$10\text{mA} \leq I_{OUT} \leq 1\text{A}$, $3\text{V} \leq (V_{IN}-V_{OUT}) \leq 10\text{V}$	1.20	1.25	1.30	V
S_V	Line Regulation	$I_{OUT} \leq 20\text{mA}$, $3\text{V} \leq V_{IN}-V_{OUT} \leq 10\text{V}$	—	0.01	0.04	%/V
S_i	Load Regulation	$V_{IN}-V_{OUT} = 2\text{V}$, $10\text{mA} \leq I_{OUT} \leq 1\text{A}$	—	0.2	0.4	%
—	Thermal Regulation	20ms Pulse	—	0.04	0.07	%/W
ΔV	Dropout Voltage	$I_{OUT} = 1\text{A}$	—	1.2	1.3	V
I_{LIMIT}	Current Limit	$(V_{IN}-V_{OUT}) = 2\text{V}$	1.2	1.5	1.8	A
—	Adjust Pin Current	—	—	50	100	μA
—	Adjust Pin Current Change	$1.4\text{V} \leq (V_{IN}-V_{OUT}) \leq 10\text{V}$, $10\text{mA} \leq I_{OUT} \leq 1\text{A}$	—	0.2	5	μA
—	Minimum Load Current	$3\text{V} \leq (V_{IN}-V_{OUT}) \leq 15\text{V}$	—	3.5	10	mA
—	Ripple Rejection	$f = 120\text{Hz}$, $C_{OUT} = 1\mu\text{F}$ Tantalum, $(V_{IN}-V_{OUT}) = 3\text{V}$, $I_{OUT} = 1\text{A}$	60	75	—	dB
—	Temperature Stability	—	—	1	—	%
—	Long-Term Stability	$T_A = +125^\circ\text{C}$, 1000hrs	—	0.3	—	%
—	RMS Output Noise (% of V_{OUT})	$T_A = +25^\circ\text{C}$, $10\text{Hz} \leq f \leq 10\text{kHz}$	—	0.003	—	%
—	Thermal Resistance (Junction to Case)	SOT223	—	15	—	$^\circ\text{C/W}$
		TO252-2 (1)/TO252-2 (3)	—	10	—	
		TO220-3	—	4.5	—	
—	Thermal Shutdown	Junction Temperature	—	+150	—	$^\circ\text{C}$
—	Thermal Shutdown Hysteresis	—	—	+25	—	$^\circ\text{C}$

Note 5: Maximum Power Dissipation is Package Type and Case Temperature dependent. Please see Figure Maximum Power Dissipation.

Performance Characteristics

Dropout Voltage vs. Output Current

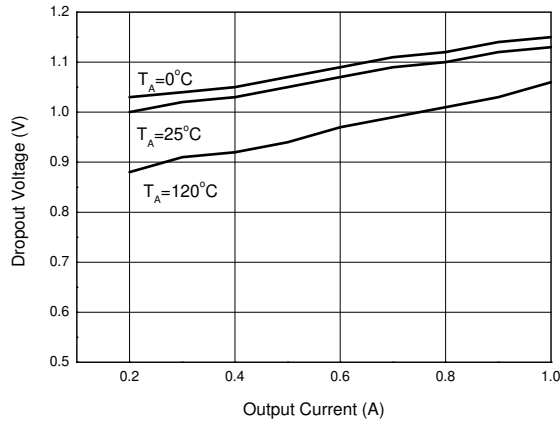

Load Regulation vs. Temperature

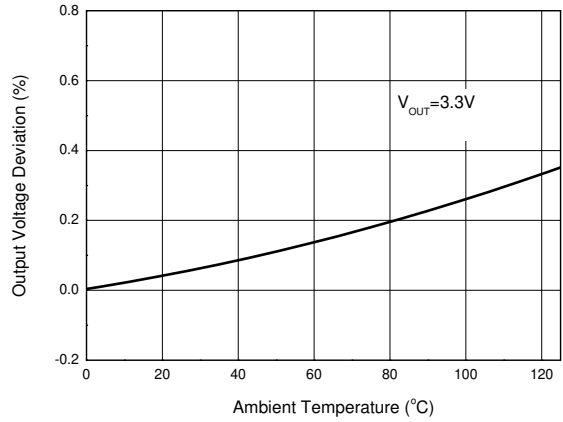

Reference Voltage vs. Temperature

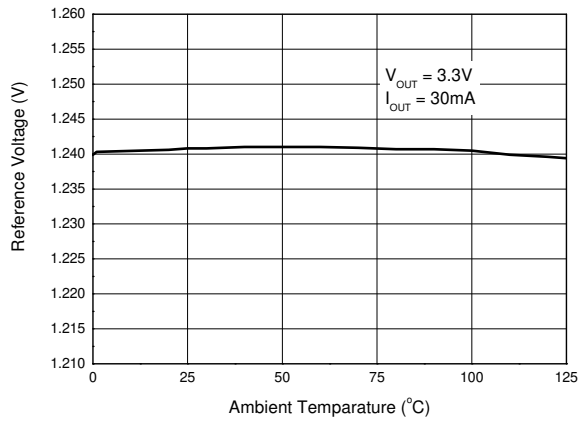

Output Voltage vs. Temperature

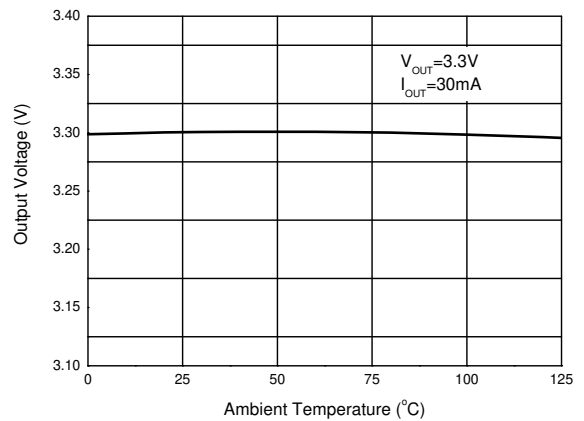

Minimum Load Current vs. Temperature

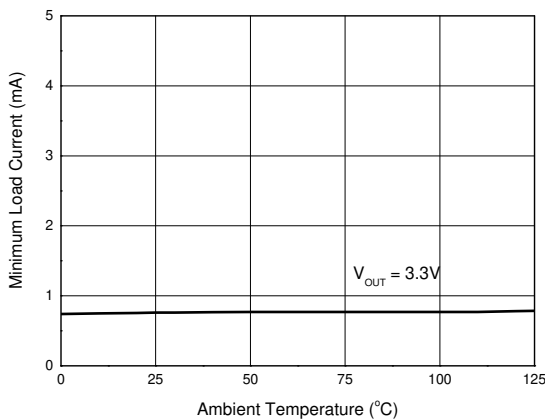

Adjust Pin Current vs. Temperature

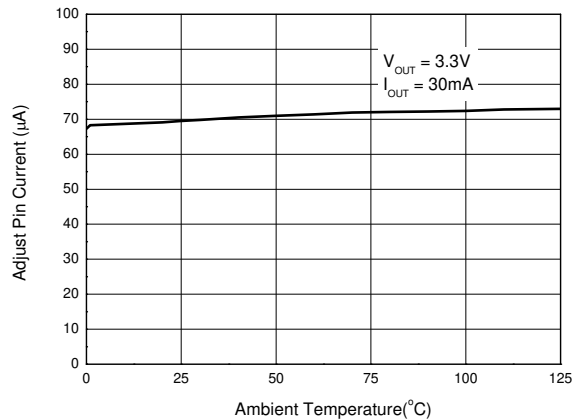

Performance Characteristics (Cont.)

Short-Circuit Current vs. Temperature

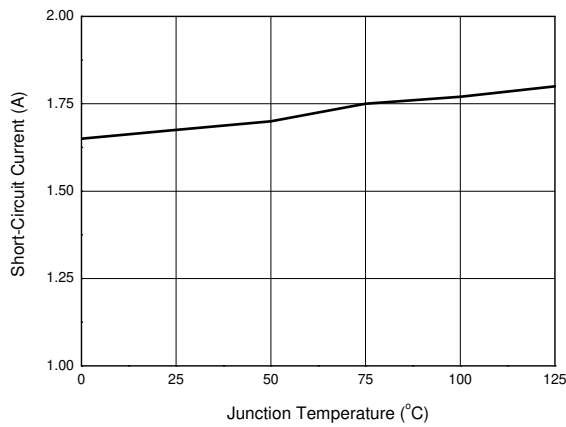

Maximum Power Dissipation

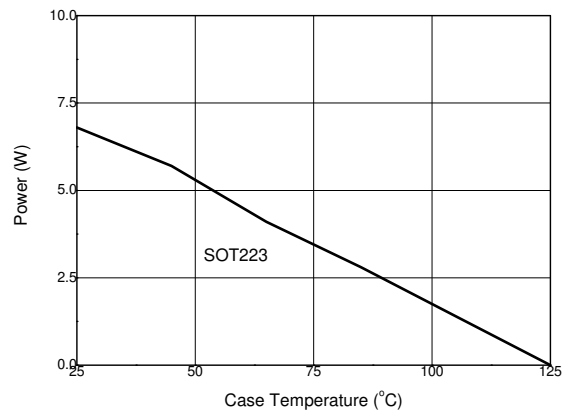

Ripple Rejection vs. Frequency

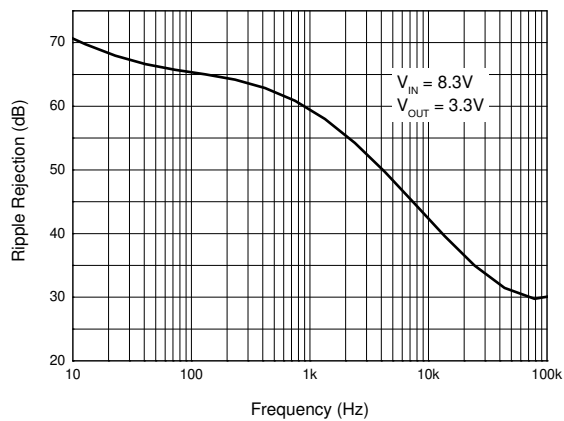

Line Transient Response

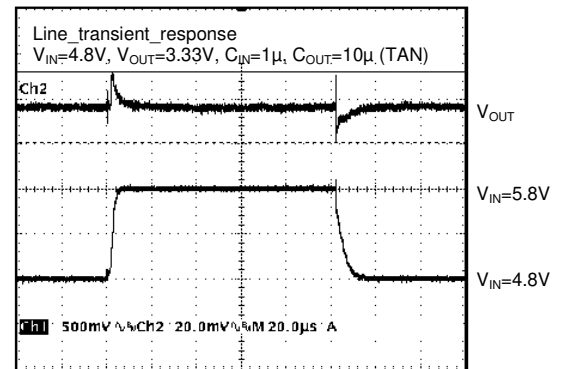

Load Transient Response

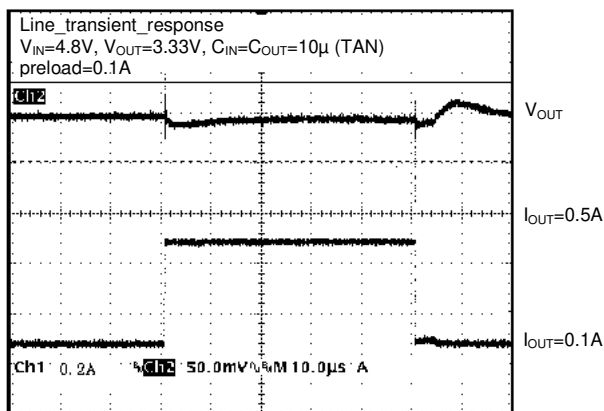

Ordering Information

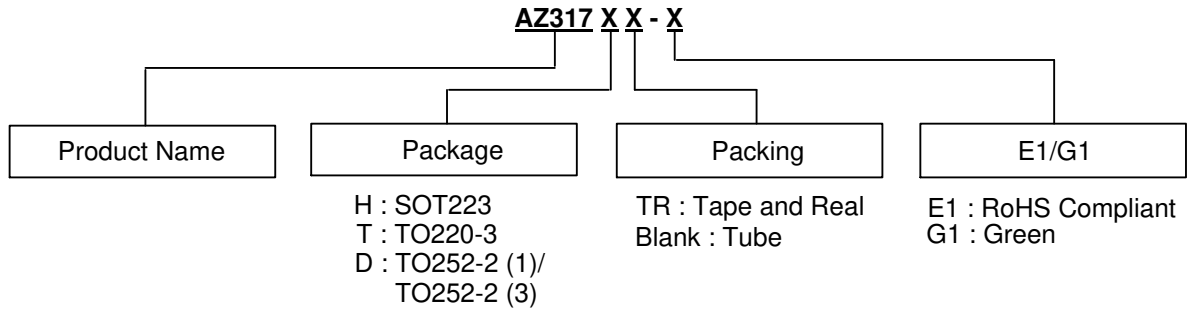

Part Number	Package (Note 7)	Temperature Range	RoHS Compliant / Green	Marking ID	Packing	Quantity	Status (Note 6)
AZ317HTR-E1	SOT223	0 to +125°C	RoHS Compliant	EH31A	Tape & Reel	1000	In Production
AZ317HTR-G1	SOT223	0 to +125°C	Green	GH31A	Tape & Reel	1000	In Production
AZ317T-E1	TO220-3	0 to +125°C	RoHS Compliant	AZ317T-E1	Tube	1000	In Production
AZ317DTR-E1	TO252-2 (1)/(3)	0 to +125°C	RoHS Compliant	AZ317D-E1	Tape & Reel	2500	In Production



Notes: 6. All variants in TO-263-3 package are End of Life without any replacement.
 AZ317DTR-G1 and AZ317T-G1 are End of Life without any replacement.
 7. For packaging details, go to our website at: <https://www.diodes.com/design/support/packaging/diodes-packaging/>.

Marking Information

(1) SOT223



First Line: Logo and Marking ID (See Ordering Information)
 Second Line: Date Code
 Y: Year
 WW: Work Week of Molding
 A: Assembly House Code
 XX: 7th and 8th Digits of Batch Number

Marking Information (Cont.)

(2) TO252-2 (1)/3

(Top View)

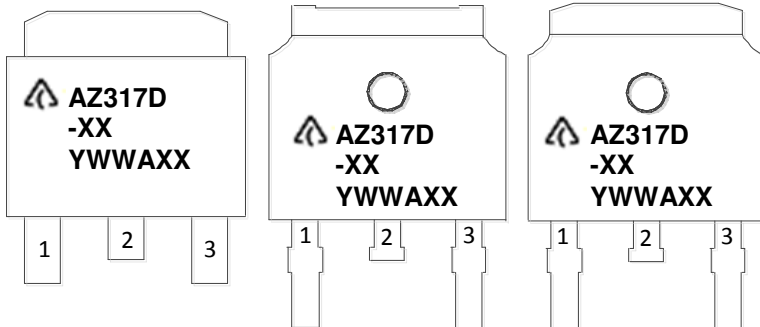

First and Second Lines: Logo and Marking ID
(See Ordering Information)
Third Line: Date Code
Y: Year
WW: Work Week of Molding
A: Assembly House Code
XX: 7th and 8th Digits of Batch Number

(3) TO220-3

(Top View)

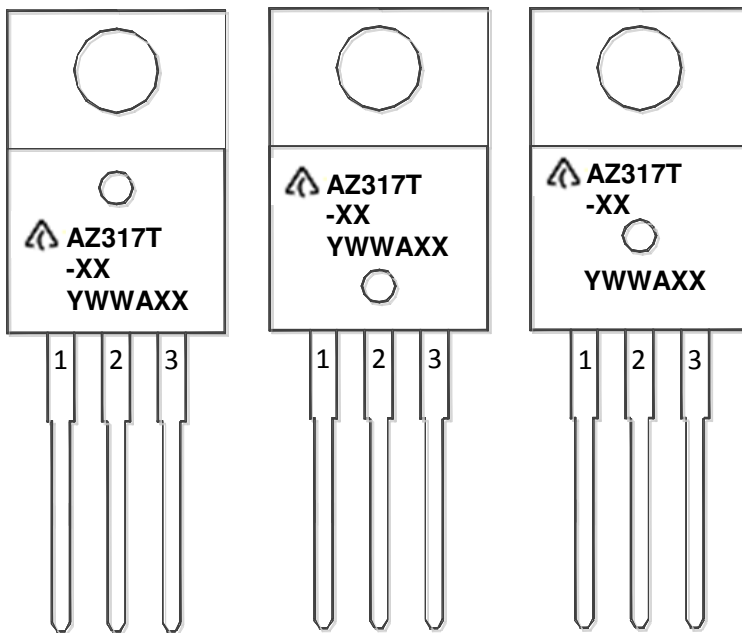

First and Second Lines: Logo and Marking ID
(See Ordering Information)
Third Line: Date Code
Y: Year
WW: Work Week of Molding
A: Assembly House Code
XX: 7th and 8th Digits of Batch Number

Package Outline Dimensions (All dimensions in mm(inch).)

(1) Package Type: SOT223

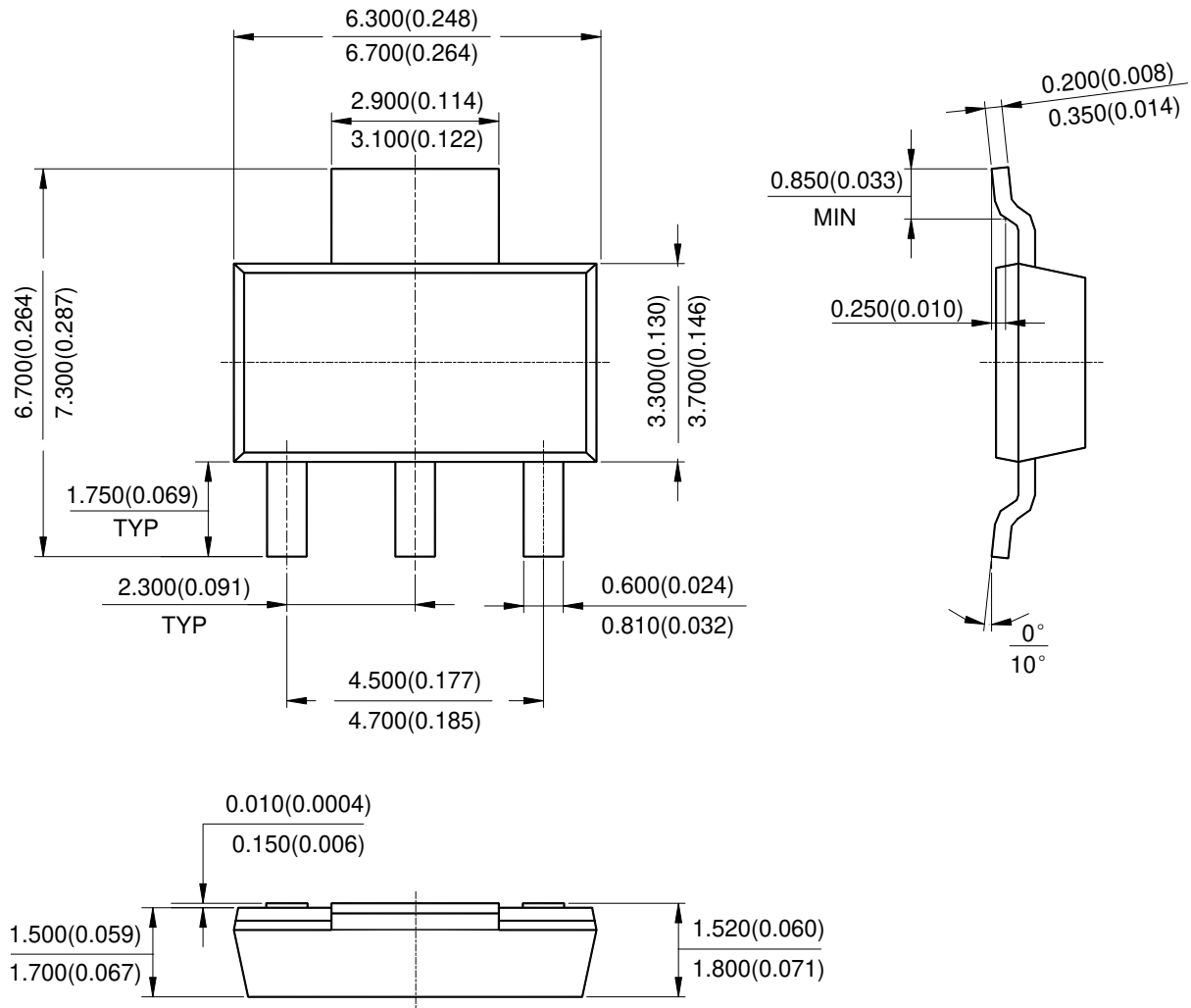

Package Outline Dimensions (Cont. All dimensions in mm(inch).)

(2) Package Type: TO220-3

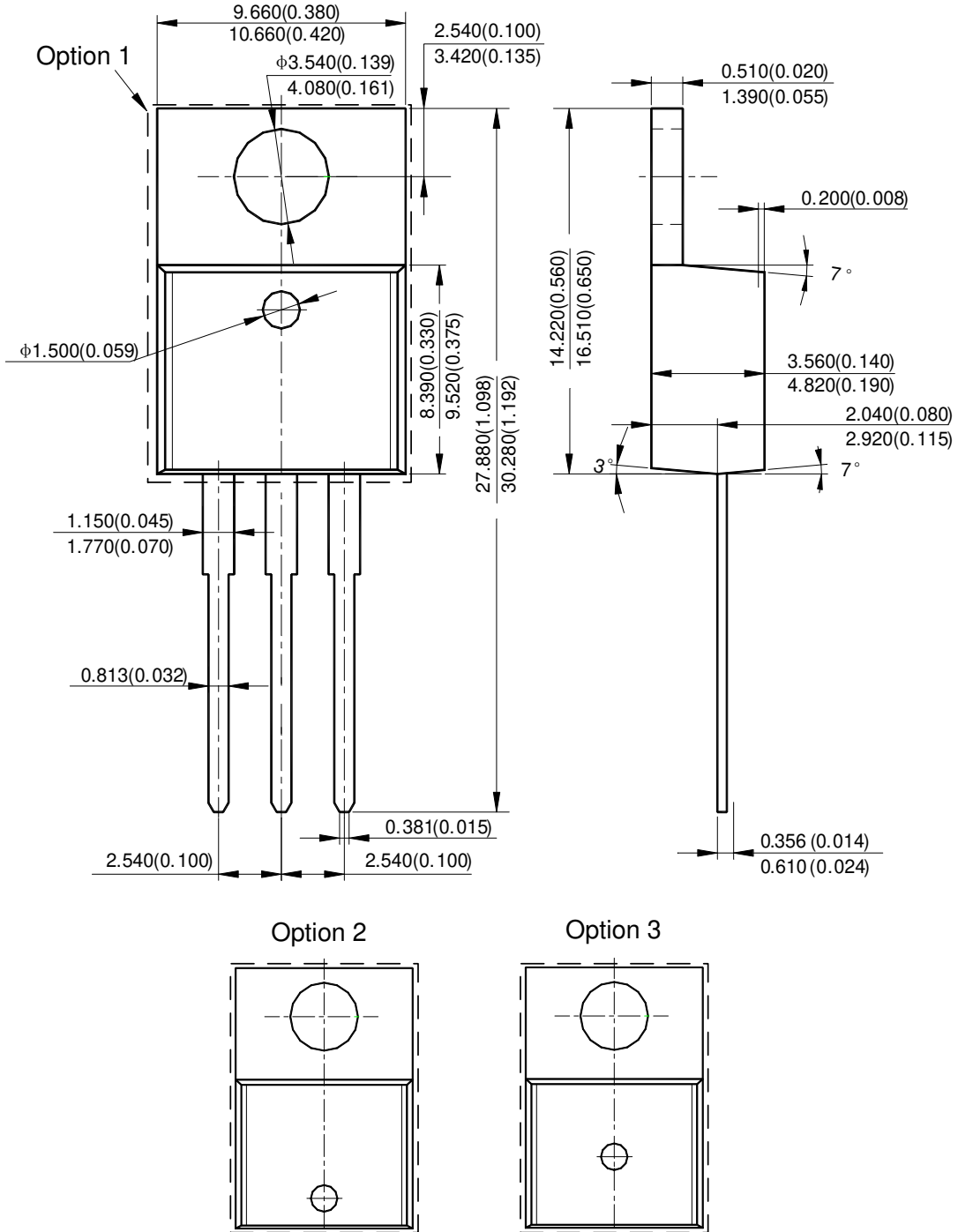

Package Outline Dimensions (Cont. All dimensions in mm(inch).)

(3) Package Type: TO252-2 (1)

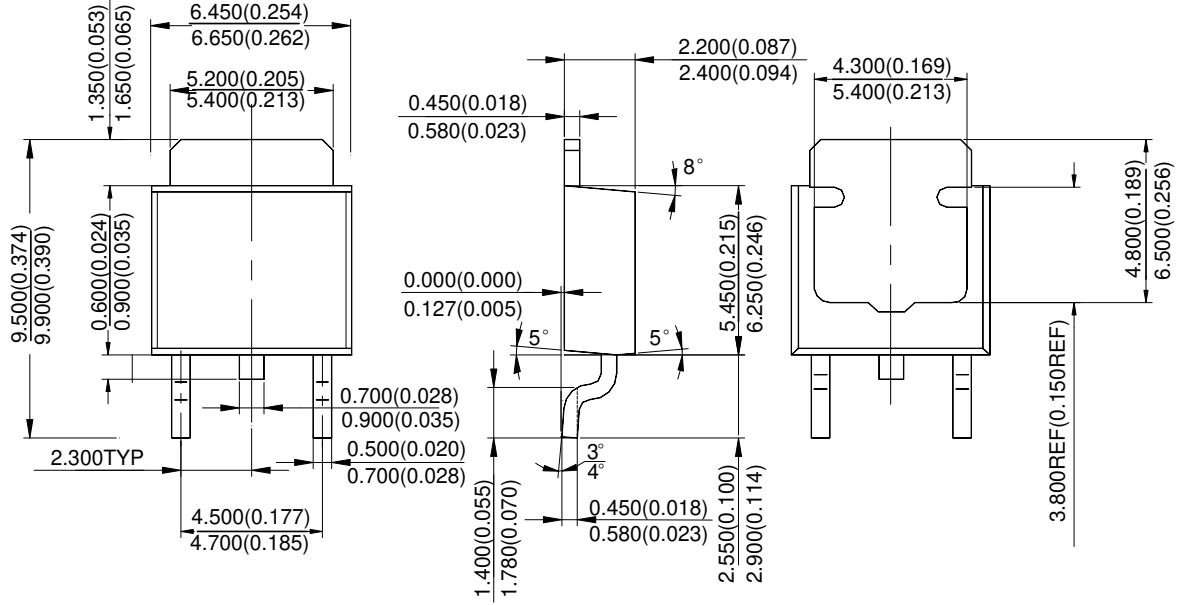

Package Outline Dimensions (Cont. All dimensions in mm(inch).)

(4) Package Type: TO252-2 (3)

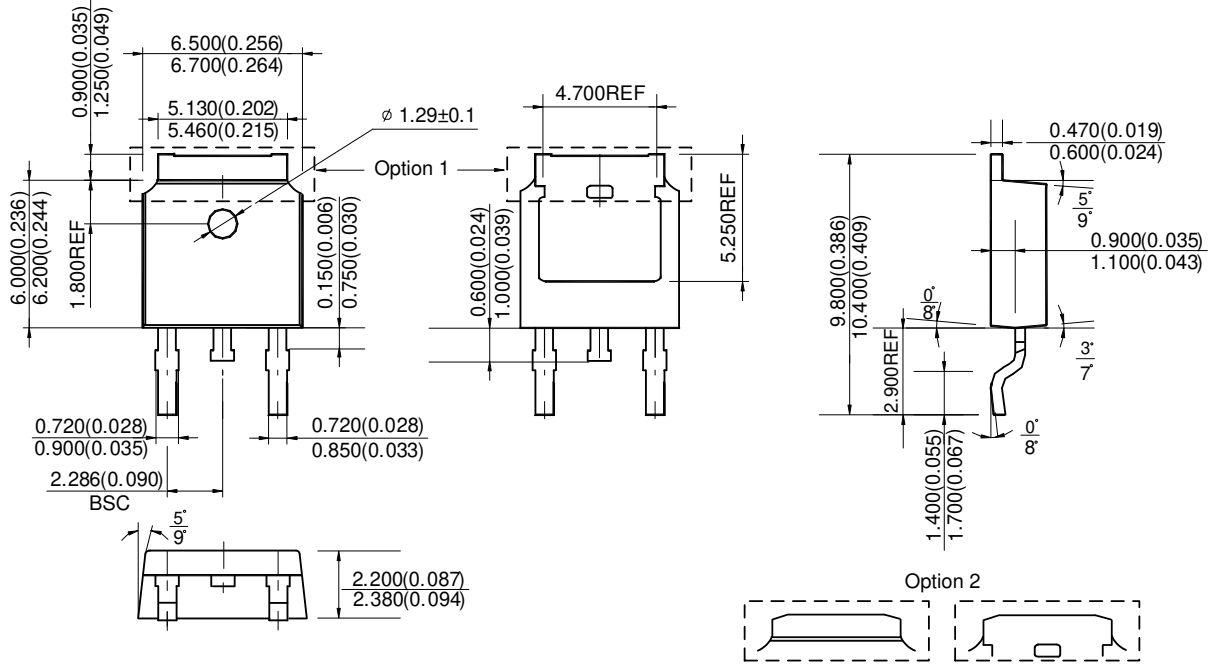

Suggested Pad Layout

(1) Package Type: SOT223

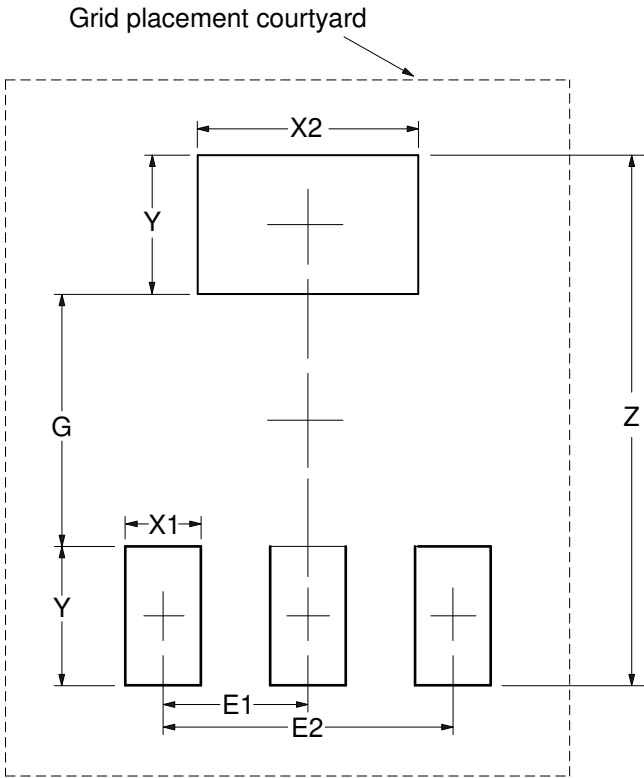

Dimensions	Z (mm)/(inch)	G (mm)/(inch)	X1 (mm)/(inch)	X2 (mm)/(inch)	Y (mm)/(inch)	E1 (mm)/(inch)	E2 (mm)/(inch)
Value	8.400/0.331	4.000/0.157	1.200/0.047	3.500/0.138	2.200/0.087	2.300/0.091	4.600/0.181

Suggested Pad Layout (Cont.)

(2) Package Type: TO252-2 (1)

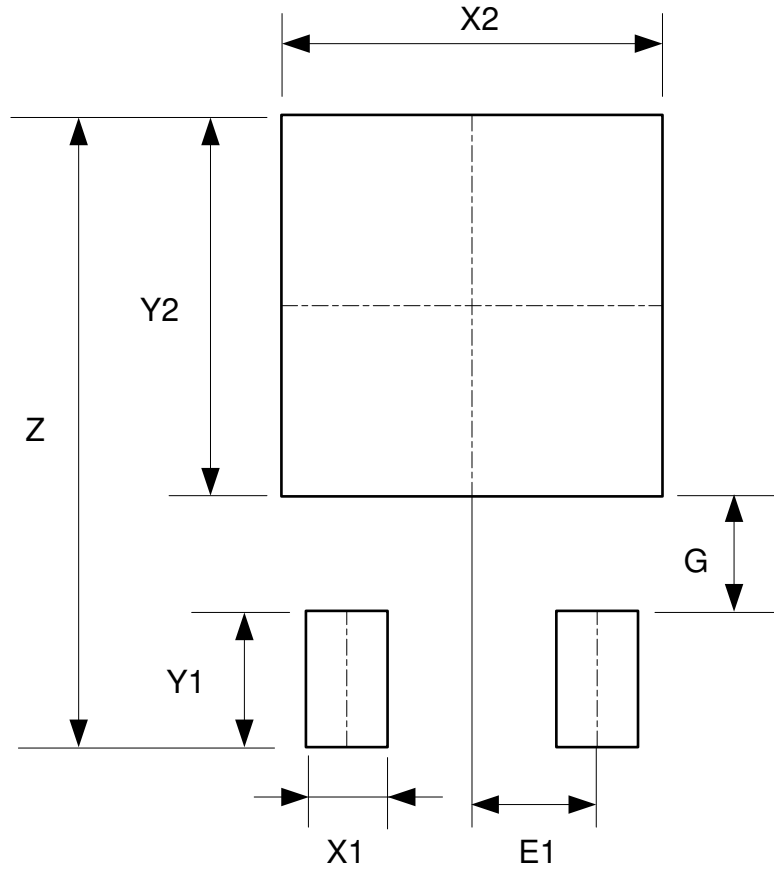

Dimensions	Z (mm)/(inch)	X1 (mm)/(inch)	X2=Y2 (mm)/(inch)	Y1 (mm)/(inch)	G (mm)/(inch)	E1 (mm)/(inch)
Value	11.600/0.457	1.500/0.059	7.000/0.276	2.500/0.098	2.100/0.083	2.300/0.091

Suggested Pad Layout (Cont.)

(3) Package Type: TO252-2 (3)

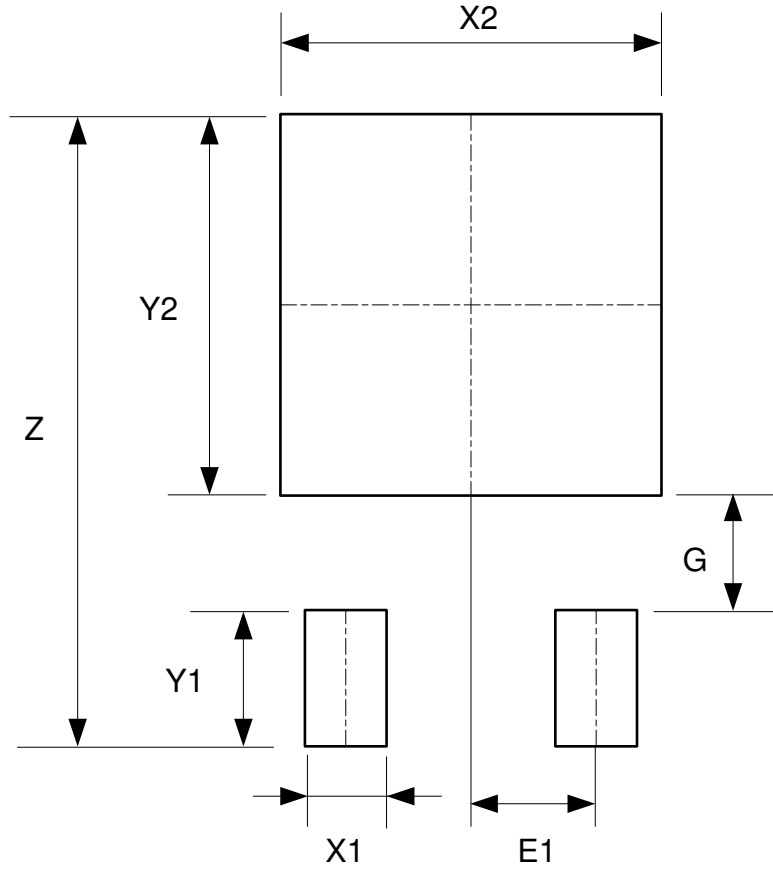

Dimensions	Z (mm)/(inch)	X1 (mm)/(inch)	X2=Y2 (mm)/(inch)	Y1 (mm)/(inch)	G (mm)/(inch)	E1 (mm)/(inch)
Value	11.600/0.457	1.500/0.059	7.000/0.276	2.500/0.098	2.100/0.083	2.300/0.091

IMPORTANT NOTICE

DIODES INCORPORATED MAKES NO WARRANTY OF ANY KIND, EXPRESS OR IMPLIED, WITH REGARDS TO THIS DOCUMENT, INCLUDING, BUT NOT LIMITED TO, THE IMPLIED WARRANTIES OF MERCHANTABILITY AND FITNESS FOR A PARTICULAR PURPOSE (AND THEIR EQUIVALENTS UNDER THE LAWS OF ANY JURISDICTION).

Diodes Incorporated and its subsidiaries reserve the right to make modifications, enhancements, improvements, corrections or other changes without further notice to this document and any product described herein. Diodes Incorporated does not assume any liability arising out of the application or use of this document or any product described herein; neither does Diodes Incorporated convey any license under its patent or trademark rights, nor the rights of others. Any Customer or user of this document or products described herein in such applications shall assume all risks of such use and will agree to hold Diodes Incorporated and all the companies whose products are represented on Diodes Incorporated website, harmless against all damages.

Diodes Incorporated does not warrant or accept any liability whatsoever in respect of any products purchased through unauthorized sales channel. Should Customers purchase or use Diodes Incorporated products for any unintended or unauthorized application, Customers shall indemnify and hold Diodes Incorporated and its representatives harmless against all claims, damages, expenses, and attorney fees arising out of, directly or indirectly, any claim of personal injury or death associated with such unintended or unauthorized application.

Products described herein may be covered by one or more United States, international or foreign patents pending. Product names and markings noted herein may also be covered by one or more United States, international or foreign trademarks.

This document is written in English but may be translated into multiple languages for reference. Only the English version of this document is the final and determinative format released by Diodes Incorporated.

LIFE SUPPORT

Diodes Incorporated products are specifically not authorized for use as critical components in life support devices or systems without the express written approval of the Chief Executive Officer of Diodes Incorporated. As used herein:

A. Life support devices or systems are devices or systems which:

1. are intended to implant into the body, or
2. support or sustain life and whose failure to perform when properly used in accordance with instructions for use provided in the labeling can be reasonably expected to result in significant injury to the user.

B. A critical component is any component in a life support device or system whose failure to perform can be reasonably expected to cause the failure of the life support device or to affect its safety or effectiveness.

Customers represent that they have all necessary expertise in the safety and regulatory ramifications of their life support devices or systems, and acknowledge and agree that they are solely responsible for all legal, regulatory and safety-related requirements concerning their products and any use of Diodes Incorporated products in such safety-critical, life support devices or systems, notwithstanding any devices- or systems-related information or support that may be provided by Diodes Incorporated. Further, Customers must fully indemnify Diodes Incorporated and its representatives against any damages arising out of the use of Diodes Incorporated products in such safety-critical, life support devices or systems.

Copyright © 2018, Diodes Incorporated

www.diodes.com