



40ACBE_4 series

40W - Single Output AC-DC Converter - Universal Input - Isolated & Regulated

AC-DC Converter 40 Watt

- ⊕ Universal 85-264VAC or 100-370VDC input voltage
- ⊕ Operating ambient temp. range: -40°C ~ +70°C
- ⊕ High I/O isolation test voltage up to 4000VAC
- ⊕ Regulated output, low ripple & noise
- ⊕ Output short circuit, over-current, over-voltage protection
- ⊕ High efficiency, high reliability
- ⊕ Plastic case meets UL94V-0 flammability
- ⊕ Meets EMI CISPR32/EN55032 CLASS B
- ⊕ EN62368 safety approved

The 40ACBE_4 series are 40W efficient environmental-protection AC-DC module power supply. It features universal AC input and at the same time accepts DC input voltage, low power consumption, high efficiency, high reliability, reinforced isolation. It offers good EMC performance compliant to IEC/EN61000-4 and CISPR32/EN55032 and meets UL62368 and EN62368 standards. The converters are widely used in control, electricity, office applications. For extremely harsh EMC environment, we recommend using the application circuit shown in design reference of this datasheet.



Common specifications	
Short circuit protection	Hiccup, continuous, self-recovery
Operating temperature range	-40°C ~ +70°C
Storage temperature range	-40°C ~ +85°C
Storage Humidity	95% MAX
Isolation (Input-output)	4000VAC (Electric Strength Test for 1min, leakage current <10mA)
Soldering temperature	Wave-soldering: 260 ± 5°C; time: 5 - 10s Manual-welding: 360 ± 10°C; time: 3 - 5s
Power derating	<ul style="list-style-type: none"> • -40°C ~ -30°C; 03/05V 4.0 %/°C MIN • -40°C ~ -30°C; 12/15V 3.0 %/°C MIN • -40°C ~ -30°C; 24/48V 2.0 %/°C MIN • -45°C ~ -70°C; 03/05V 3.0 %/°C MIN • -55°C ~ -70°C; 12/15V 3.7 %/°C MIN • -55°C ~ -70°C; 24/48)V 2.7 %/°C MIN • 85VAC-100VAC 1.33 %/VAC MIN
Safety standards	IEC62368/EN62368/UL62368
Safety Certification	EN62368
Safety class	CLASS II
MTBF (MIL-HDBK-217F@25°C)	>300,000h
Dimension	89.00 x 63.50 x 25.00 mm 135.00 x 70.00 x 33.50 mm (Chassis mounting) 137.00 x 70.00 x 39.00 mm (Din-rail mounting)
Weight	215g TYP 300g TYP (Chassis mounting) 360g TYP (Dinrail mounting)
Case material	Black plastic, flame-retardant and heat-resistant (UL94V-0)
Cooling	Free air convection

Input specifications					
Item	Test conditions	Min	Typ	Max	Units
Input Voltage Range	• AC input	85		264	VAC
	• DC input	100		370	VDC
Input frequency		47		63	Hz
Input current	• 115VAC			1.0	A
	• 230VAC			0.6	A
Inrush current (Cold start)	• 115VAC		50		A
	• 230VAC		70		A
Hot plug	Unavailable				

Output specifications					
Item	Test conditions	Min	Typ	Max	Units
Output voltage accuracy	All load rang		±2.0		%
Line regulation	Rated load		±0.5		%
Load regulation	0% - 100% load • 3.3V/5V • 12V/15V/24V/48V		±1.0	±3	%
			±1.0	-	%
Ripple & noise*	20MHz bandwidth; peak-to-peak value		80	150	mV
Temperature coefficient	0% - 100% load		±0.02		%/°C
Stand-by power consumption				0.5	W
Over-current Protection	≥110%Io, self-recovery				
Over-voltage Protection	<ul style="list-style-type: none"> • 3.3V Output • 5V Output • 12V Output • 15V Output • 24V Output • 48V Output 			5.5	V
				9	V
				16	V
				24	V
				35	V
Minimum load		0			%
Hold-up time	<ul style="list-style-type: none"> • 115VAC • 230VAC 		10		ms
			50		ms
Switching Frequency			65		kHz
Short Circuit Protection	Hiccup, continuous, self-recovery				

*The "parallel cable" method is used for ripple and noise test, please refer to AC-DC

Example:

40ACBE_05S4

40 = 40Watt; AC = AC-DC; B = case style; E = Cost effective; 05 = 5Vout; S = Single Output; 4 = 4kVAC isolation

Note:

1. Unless otherwise specified, parameters in this datasheet were measured under the conditions of Ta = 25°C, humidity <75% with nominal input voltage and rated output load;
2. All index testing methods in this datasheet are based on our company corporate standards;
3. We can provide product customization service, please contact our technicians directly for specific information;
4. Products are related to laws and regulations: see „Features“ and „EMC“;
5. Our products shall be classified according to ISO14001 and related environmental laws and regulations, and shall be handled by qualified units.

40ACBE_4 series

40W - Single Output AC-DC Converter - Universal Input - Isolated & Regulated

EMC specifications			
Emissions	CE	CISPR32/EN55032	CLASS B
Emissions	RE	CISPR32/EN55032	CLASS B
Immunity	ESD	IEC/EN 61000-4-2	Contact ±6KV / Air ±8KV
Immunity	RS	IEC/EN 61000-4-3	10V/m
Immunity	EFT	• IEC/EN 61000-4-4 • IEC/EN 61000-4-4	± 2kV ± 4kV (see EMC recommended circuit)
Immunity	Surge	• IEC/EN 61000-4-5 • IEC/EN 61000-4-5	line to line ±1KV/ line to ground ±2KV line to line ±2KV/ line to ground ±4KV (see EMC recommended circuit)
Immunity	CS	IEC/EN61000-4-6	10 Vr.m.s

Certification	Model	Output power [W]	Output [V]	Output [mA]	Efficiency [%, typ]	Capacitive load [µF, max]
UL	40ACBE_03S4	26.4	3.3	8000mA	78	60000
UL	40ACBE_05S4	40	5	8000mA	82	40000
UL	40ACBE_12S4	40	12	3330mA	84	9000
UL	40ACBE_15S4	40	15	2660mA	84	7000
UL	40ACBE_24S4	40	24	1670mA	84	2000
UL	40ACBE_48S4	40	48	830mA	84	1000

* Add suffix CM for Chassis mounting with screw terminals (e.g. 40ACBE_48S4CM), see different package measurements.

* Add suffix DR for DIN rail mounting with screw terminals (e.g. 40ACBE_48S4DR), see different package measurements.

Typical characteristics

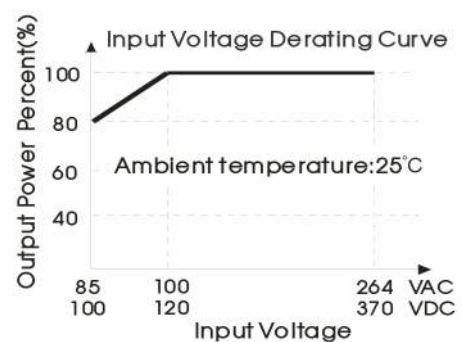
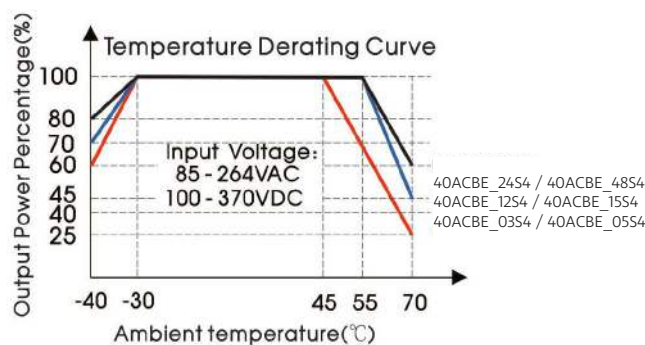

Note:

- ① With an AC input between 85-100VAC and a DC input between 100-120VDC, the output power must be derated as per temperature derating curves;
- ② This product is suitable for applications using natural air cooling; for applications in closed environment please consult one of our FAE.

Efficiency

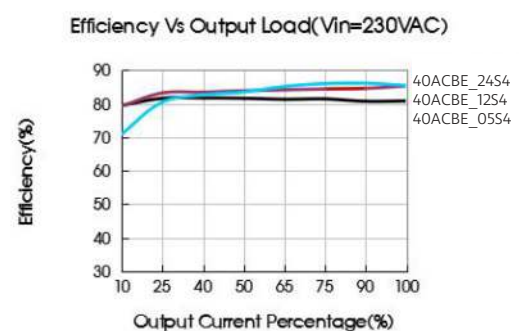
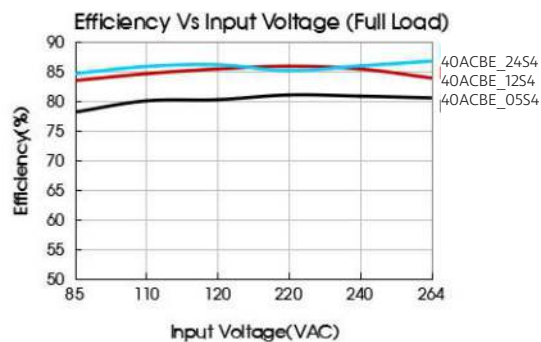

40ACBE_4 series

40W - Single Output AC-DC Converter - Universal Input - Isolated & Regulated

Typical application circuit

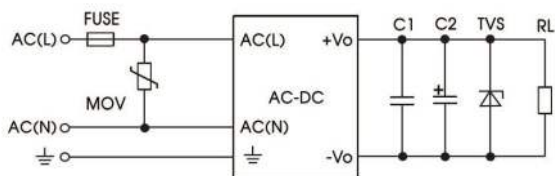

Note:

We recommend using an electrolytic capacitor with high frequency, and low ESR rating for C2 (refer to manufacture's datasheet). Choose a capacitor voltage rating with at least 20% margin, in other words not exceeding 80%. C1 is a ceramic capacitor used for filtering high-frequency noise and TVS is a recommended suppressor diode to protect the application in case of a converter failure.

Model	C1 (μF)	C2 (μF)	TVS
40ACBE_03S4	1	680	SMBJ7.0A
40ACBE_05S4	1	680	SMBJ7.0A
40ACBE_12S4	1	220	SMBJ20A
40ACBE_15S4	1	220	SMBJ20A
40ACBE_24S4	1	120	SMBJ30A
40ACBE_48S4	1	100	SMBJ64A

EMC compliance recommended circuit

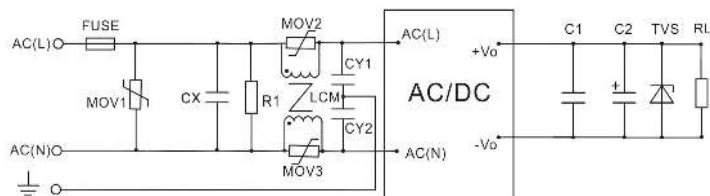
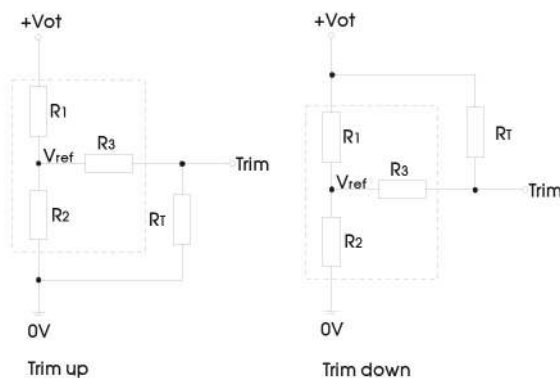

Fig.2 (Output external circuit refer to the typical application circuit)

Component	Recommended value
MOV	S14K350
CY1, CY2	2.2nF/400VAC
CX	0.15μF/300VAC
LCM	2.2mH
R1	1MΩ/2W
FC-LX1D	2KV/4KV EMC filter
FUSE	3.15A/300V slow-blow, required

Trim



TRIM resistor connection (dashed line shows internal resistor network)

Calculating Trim resistor values:

$$\text{up: } R_T = \frac{\alpha R_2}{R_2 - \alpha} \cdot R_3 \quad \alpha = \frac{V_{ref}}{V_{ot} - V_{ref}} \cdot R_1$$

$$\text{down: } R_T = \frac{\alpha R_1}{R_1 - \alpha} \cdot R_3 \quad \alpha = \frac{V_{ot} - V_{ref}}{V_{ref}} \cdot R_2$$

R_T = Trim Resistor value;
 α = self-defined parameter;
 V_{ot} = desired output voltage ($\pm 10\%$ max.).

Vout nominal	R1(KΩ)	R2(KΩ)	R3(KΩ)	Vref(V)	Vot(V)
3.3V	2	1.2	1	1.24	Resulting Trimmed Output voltage; range $\leq \pm 10\%$
5V	3.3	3.3	1	2.5	
12V	3.83	1	1	2.5	
15V	7.5	1.5	1	2.5	
24V	8.66	1	1	2.5	
48V	22	1.2	1	2.5	

40ACBE_4 series

40W - Single Output AC-DC Converter - Universal Input - Isolated & Regulated

Mechanical dimensions

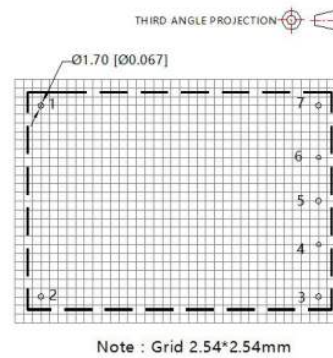
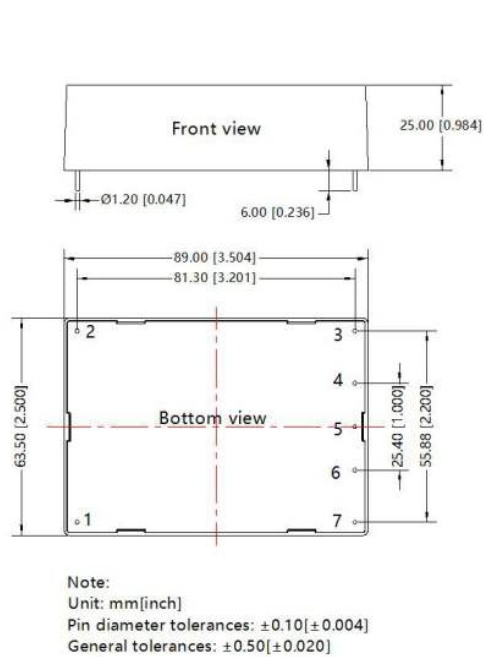

Pin-Out	
Pin	LHE40-20B
1	AC(L)
2	AC(N)
3	Trim
4	No Pin
5	-Vo
6	No Pin
7	+Vo

Chassis mounting

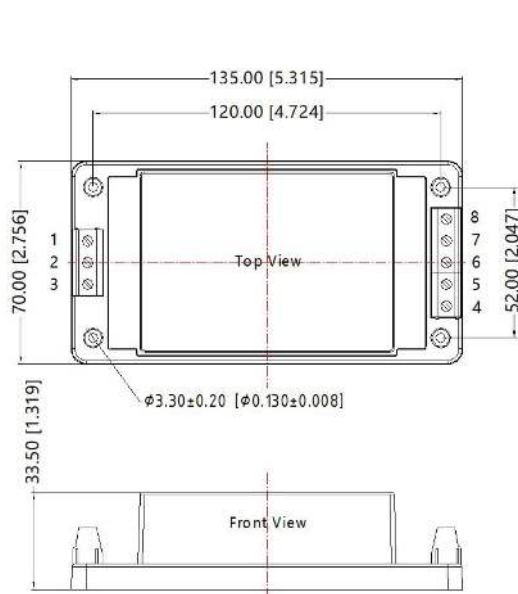

THIRD ANGLE PROJECTION

Pin-Out	
Pin	LHE40-20B
1	AC(L)
2	AC(N)
3	NC
4	Trim
5	NC
6	-Vo
7	NC
8	+Vo

Note:
 Unit: mm[inch]
 Wire range: 24-12 AWG
 Tightening torque: Max 0.4 N-m
 General tolerances: ± 1.00 [± 0.040]

40ACBE_4 series

40W - Single Output AC-DC Converter - Universal Input - Isolated & Regulated

Din Rail mounting

THIRD ANGLE PROJECTION 

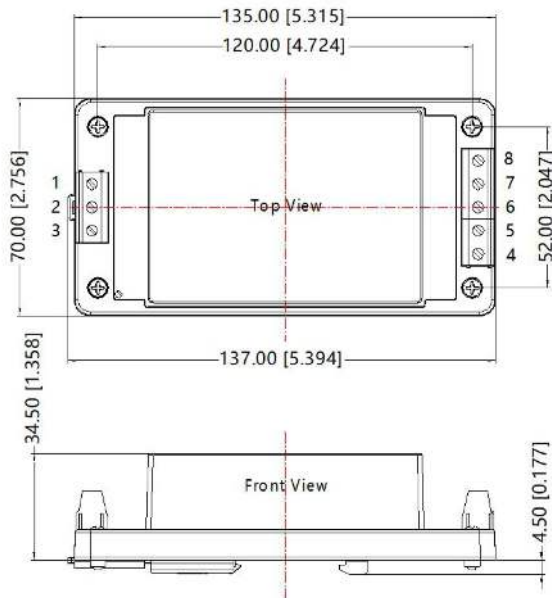

Pin-Out	
Pin	LHE40-20B
1	AC(L)
2	AC(N)
3	NC
4	Trim
5	NC
6	-Vo
7	NC
8	+Vo

Note:

Unit: mm[inch]

Wire range: 24-12 AWG

Tightening torque: Max 0.4 N·m

Mounting rail: TS35, rail needs to connect safety ground

General tolerances: $\pm 1.00[\pm 0.040]$