

CERAMICS SMD ULTRA MINIATURE QUARTZ CRYSTAL



ABM11

2.0 x 1.6 x 0.59mm

ABM11

RoHS/RoHS II Compliant

Moisture Sensitivity Level (MSL) – This product is Hermetically Sealed and not Moisture Sensitive - MSL = N/A: Not Applicable

FEATURES:

- 2.0 x 1.6 x 0.59mm ultra miniature package.
- Suitable for RoHS compliant reflow.
- Seam sealed ceramic package with metal lid assures high precision and reliability.

APPLICATIONS:

- Cellular telephones, Pagers.
- Communication and Test equipment.
- High Density applications
- PCMCIA and wireless applications.

STANDARD SPECIFICATIONS:

| Parameters | Minimum | Typical | Maximum | Units | Notes |
|---|-------------|---------|---------|-------|--|
| Frequency Range | 16.000 | | 50.000 | MHz | |
| Operation Mode | Fundamental | | | | |
| Operating Temperature | -10 | | +60 | °C | See options |
| Storage Temperature | -40 | | +85 | °C | |
| Frequency Tolerance @+25°C | -30 | | +30 | ppm | See options |
| Frequency Stability over the Operating Temperature (ref. to +25°C) | -50 | | +50 | ppm | See options |
| Equivalent series resistance (R1) | | | 150 | Ω | 16.000~17.999MHz |
| | | | 120 | | 18.000~20.999MHz |
| | | | 100 | | 21.000~29.999 MHz |
| | | | 80 | | 30.000~37.999 MHz |
| | | | 60 | | 38.000~50.000 MHz |
| Shunt capacitance (C0) | | | 7.0 | pF | |
| Load capacitance (CL) | 10 | | | pF | Standard (See options if other than STD) |
| Drive Level | | 10 | 100 | μW | |
| Aging | -5 | | +5 | ppm | @25°C±3°C First year |
| Insulation Resistance | 500 | | | MΩ | @ 100Vdc ± 15V |

OPTIONS AND PART IDENTIFICATION: (Left blank if standard)

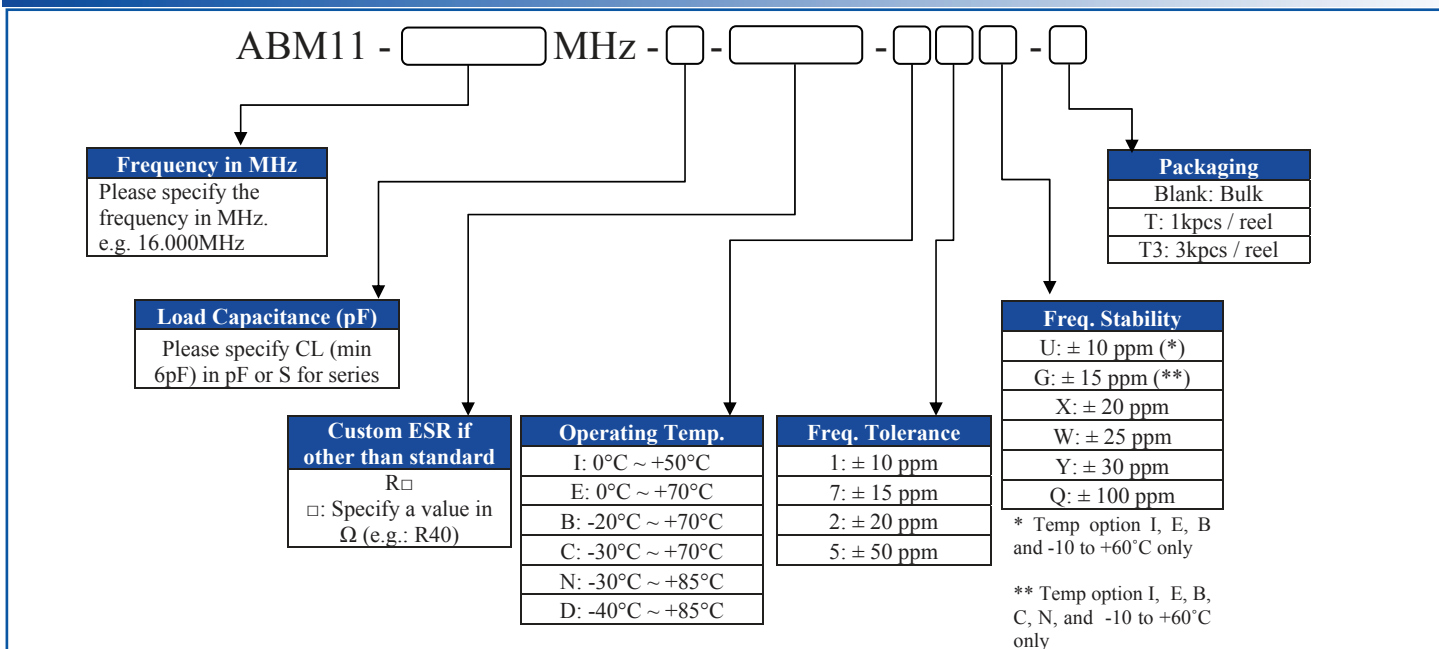

CERAMICS SMD ULTRA MINIATURE QUARTZ CRYSTAL



ABM11

2.0 x 1.6 x 0.59mm

ABM11

Pb RoHS/RoHS II Compliant

OUTLINE DRAWING:

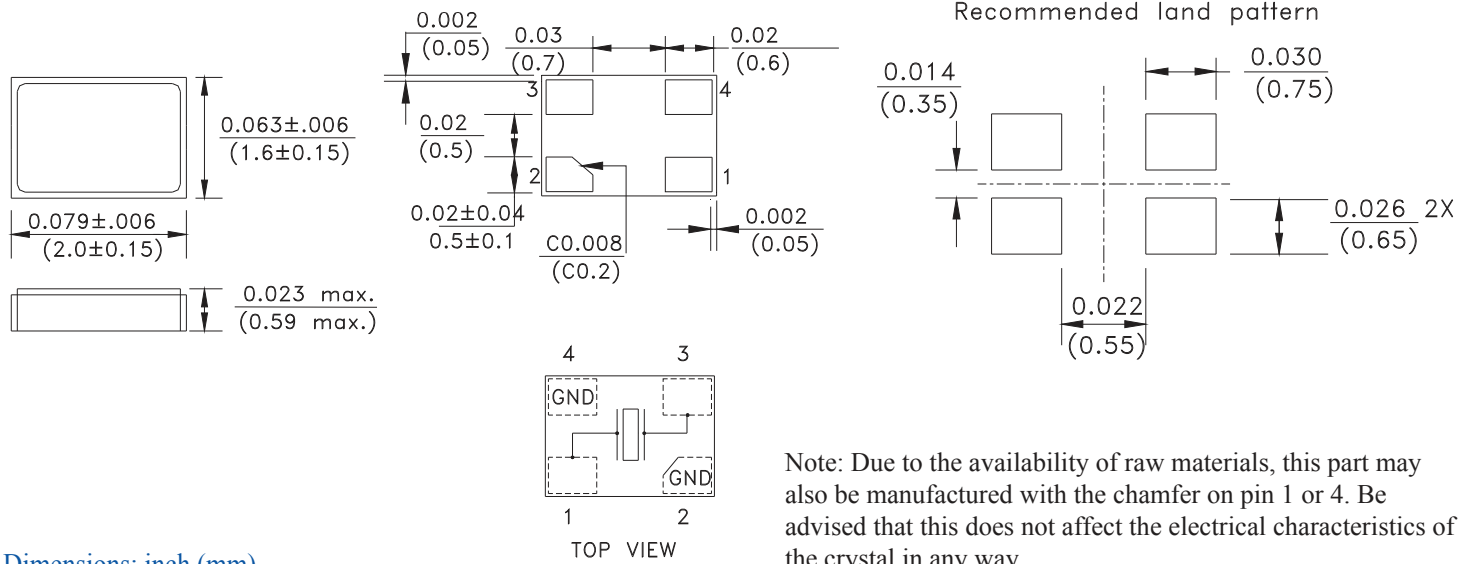

TAPE & REEL:

Option "-T": Tape and reel (1,000pcs/reel)
 Option "-T3": Tape and reel (3,000pcs/reel)

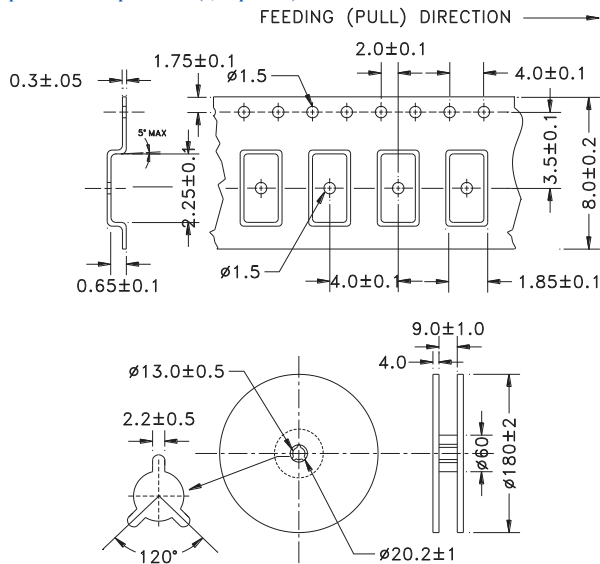

REFLOW PROFILE:

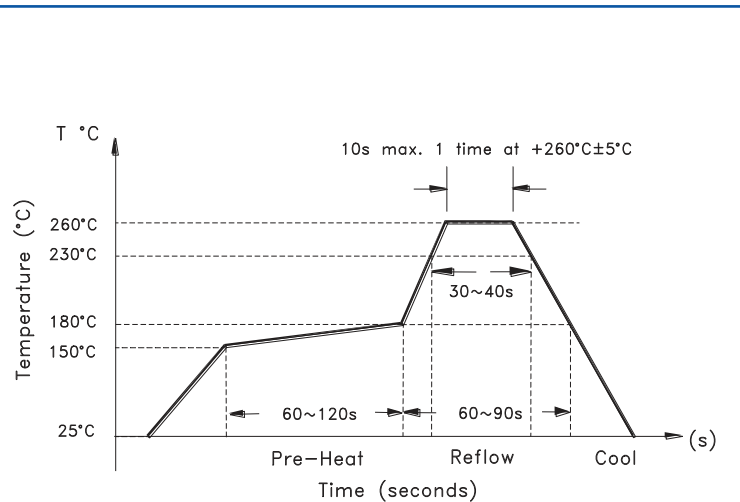

Need a test socket for the ABM11 Series? To view compatible **PRECISION TEST & BURN-IN SOCKETS** for these parts, [click here](#). P/N AXS-2016-04-04C

ATTENTION: Abracon Corporation's products are COTS – Commercial-Off-The-Shelf products; suitable for Commercial, Industrial and, where designated, Automotive Applications. Abracon's products are not specifically designed for Military, Aviation, Aerospace, Life-dependant Medical applications or any application requiring high reliability where component failure could result in loss of life and/or property. For applications requiring high reliability and/or presenting an extreme operating environment, written consent and authorization from Abracon Corporation is required. Please contact Abracon Corporation for more information.

ABRACON IS
 ISO 9001: 2008
 CERTIFIED



2 Faraday, Suite# B | Irvine | CA 92618 Revised: 06.19.15
 Ph. 949.546.8000 | Fax. 949.546.8001
 Visit www.abracon.com for Terms and Conditions of Sale