

THIS DRAWING IS UNPUBLISHED. RELEASED FOR PUBLICATION OCT, 1978.
 © COPYRIGHT 1978 BY TYCO ELECTRONICS CORPORATION. ALL RIGHTS RESERVED.

LOC	DIST	REVISIONS					
P	LTR	DESCRIPTION	DATE	DWN	APVD		
J	/	A	RELEASED	ECR-05-009552	15AUG05	C.Z	S.Y

-2; AS SHOWN

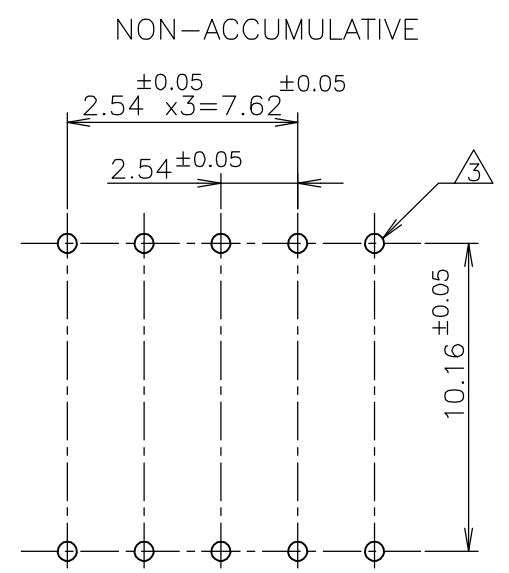
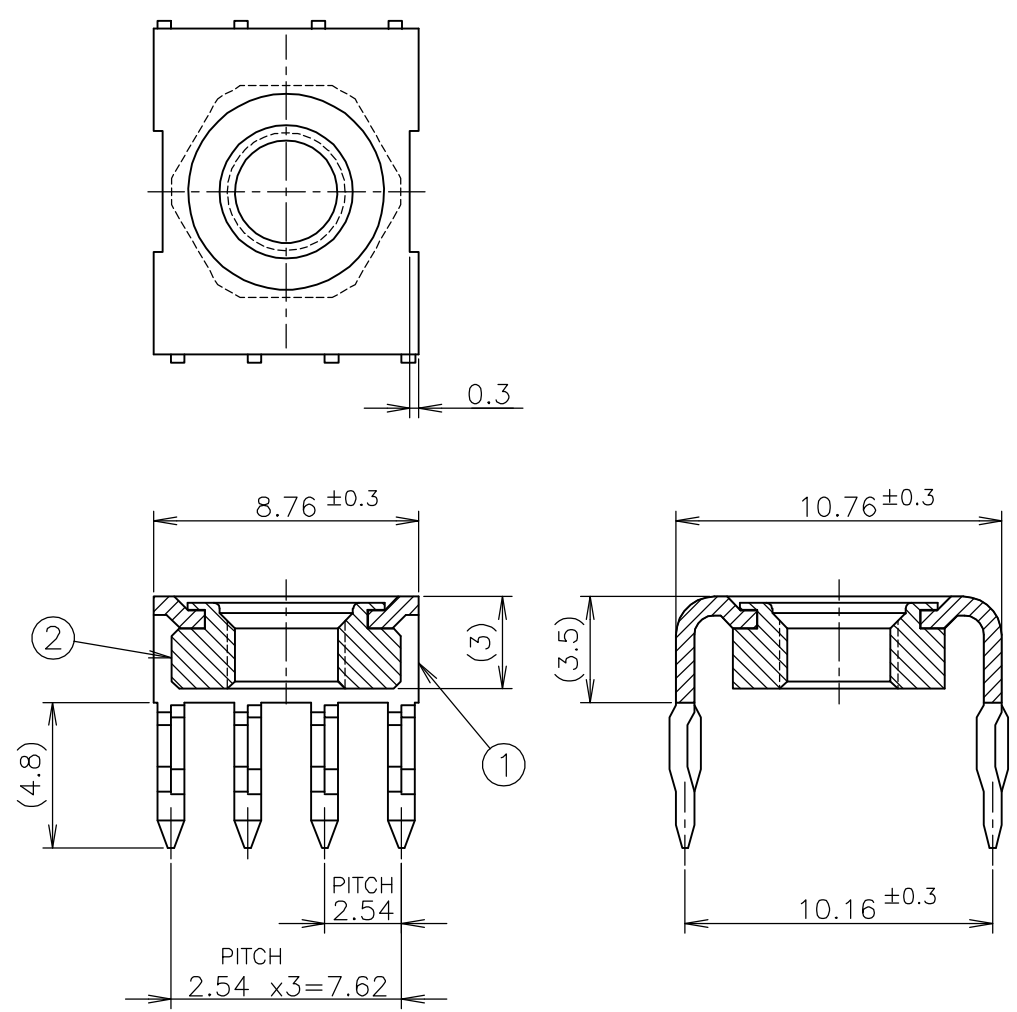

RECOMMENDED PCB LAYOUT
(SEE NOTE 3)

- NOTES:
- USE SCREW AND SPRING WASHER AS FOLLOWING:
 M4 SCREW
 SPRING WASHER: NOMINAL DIAMETER 4.
 - RECOMMENDED PCB LAYOUT (USED BY ACTION-PIN)
 - PCB MATERIAL: GLASS EPOXY
 NEMA GIO, GII, FR4
 - PCB THICKNESS: 1.5MIN.
 - THRU HOLE TREATMENT: $\phi 1.0^{\pm 0.025}$
 - COPPER FOIL THICKNESS: 25~75u
 - COPPER FOIL HARDNESS: 150KNOOPMAX.
 - FINISH DIAMETER: $\phi 0.9^{\pm 0.05}$ (AFTER PL.)
 - IF IT IS USED BY SOLDERING,
 THRU HOLE DIAMETER: $\phi 1.30^{\pm 0.05}$ (8 POSITIONS)

M4 CURLING NUT	②
8P POWER TAP CONTACT	①
NAME	ITEM

GENERAL TOLERANCE
 $10 \geq : \pm 0.2$
 $30 \geq > 10 : \pm 0.25$
 $100 \geq > 30 : \pm 0.3$
 ANGLES: $\pm 3'$

THIS DRAWING IS A CONTROLLED DOCUMENT.	
DIMENSIONS: mm	TOLERANCES UNLESS OTHERWISE SPECIFIED:
	0 PLC ± -
	1 PLC ± -
	2 PLC ± -
	3 PLC ± -
	4 PLC ± -
	ANGLES ± -
MATERIAL COPPER ALLOY	FINISH TIN PL.

DWN C.ZHU 15AUG05	Tyco Electronics AMP K.K. Kawasaki, Japan
CHK I.WANG 15AUG05	
APVD S.YAO 15AUG05	
PRODUCT SPEC	
APPLICATION SPEC	NAME 8POS AMP POWER TAP CONNECTOR
WEIGHT	SIZE A3
CUSTOMER DRAWING	CAGE CODE 00779
	DRAWING NO C-5174882
	RESTRICTED TO -
	SCALE 4:1
	SHEET 1 OF 1
	REV A