



List of "SFV__R-3/4STE1HLF" customer document

| DOCUMENT NO. | LIST |
|------------------|--|
| 10117319(Sheet1) | DOCUMENT LIST |
| 10117319(Sheet2) | CAT.NO.TABLE FOR 0.5mm CONTACT SPACING CONNECTOR (SFV__R-3/4ST_HLF) |
| 10117319(Sheet3) | CONNECTOR USED FOR FPC WITH 0.5mm CONTACT SPACING (SFV__R-3ST_HLF) |
| 10117319(Sheet4) | CONNECTOR USED FOR FPC WITH 0.5mm CONTACT SPACING (SFV__R-4ST_HLF) |
| 10117319(Sheet5) | CAT.NO.TABLE FOR PLASTIC TAPE PACKAGED 0.5mm CONTACT SPACING CONNECTOR (SFV__R-3/4STE1HLF) |
| 10117319(Sheet6) | PLASTIC TAPE PACKAGED 0.5mm CONTACT SPACING CONNECTOR (SFV__R-3STE1HLF) |
| 10117319(Sheet7) | PLASTIC TAPE PACKAGED 0.5mm CONTACT SPACING CONNECTOR (SFV__R-4STE1HLF) |
| 10117319(Sheet8) | RECOMMENDED CABLE (FPC) (SFV__R-3/4ST_HLF) |
| GS-12-0844 | SPEC. |
| BJM-SFV102 | HANDLING PROCEDURES |

| | | | | | | | | | | | | | |
|-------------|----------------|-----|-----------|--|------------|----------------------------|---|------------|---|---|--|--------------|------|
| mat'l. code | | | | surface ISO 1302 <input checked="" type="checkbox"/> | | tolerance ISO 406 ISO 1101 | | projection | | product family 58EF | | | |
| ltr | ecn no | dr | date | tolerances unless otherwise specified | | | | | | title | | | |
| A | J11-0042 | S.W | 2011-2-10 | angles | linear | | | | | 0.5mm SPACING FPC CONNECTOR DOCUMENT LIST | | | |
| B | ELX-J-32839 | S.W | 2019-3-6 | | | | | | | (Cat. No. : SFV__R-3/4STE1HLF) | | | |
| | | | | dr | S.WATANABE | 2019-3-6 | | | | dwg no | | sheet 1 of 8 | size |
| | | | | enr | S.WATANABE | 2019-3-6 | | | | 10117319 | | A4 | |
| | | | | chr | S-H.THIO | 2019-3-7 | | | | | | | |
| | | | | appd | Y.KAMEDA | 2019-3-7 | | | | | | | |
| sheet index | revision sheet | B | B | B | B | B | B | B | B | type Product Customer Drawing | | | |
| | | 1 | 2 | 3 | 4 | 5 | 6 | 7 | 8 | | | | |

CAT. NO. & DIMENSIONS

| NO. OF CONTACTS (n) | CAT. NO. | DIMENSIONS (NOTE2) | | | |
|---------------------|-------------------|--------------------|---------|---------|---------|
| | | A ± 0.2 | B ± 0.2 | C ± 0.1 | D ± 0.1 |
| 4 | SFV 4R-3/4ST__HLF | 7.5 | 5.9 | 1.5 | 1.6 |
| 5 | SFV 5R-3/4ST__HLF | 8.0 | 6.4 | 2.0 | 2.1 |
| 6 | SFV 6R-3/4ST__HLF | 8.5 | 6.9 | 2.5 | 2.6 |
| 7 | SFV 7R-3/4ST__HLF | 9.0 | 7.4 | 3.0 | 3.1 |
| 8 | SFV 8R-3/4ST__HLF | 9.5 | 7.9 | 3.5 | 3.6 |
| 9 | SFV 9R-3/4ST__HLF | 10.0 | 8.4 | 4.0 | 4.1 |
| 10 | SFV10R-3/4ST__HLF | 10.5 | 8.9 | 4.5 | 4.6 |
| 11 | SFV11R-3/4ST__HLF | 11.0 | 9.4 | 5.0 | 5.1 |
| 12 | SFV12R-3/4ST__HLF | 11.5 | 9.9 | 5.5 | 5.6 |
| 13 | SFV13R-3/4ST__HLF | 12.0 | 10.4 | 6.0 | 6.1 |
| 14 | SFV14R-3/4ST__HLF | 12.5 | 10.9 | 6.5 | 6.6 |
| 15 | SFV15R-3/4ST__HLF | 13.0 | 11.4 | 7.0 | 7.1 |
| 16 | SFV16R-3/4ST__HLF | 13.5 | 11.9 | 7.5 | 7.6 |
| 17 | SFV17R-3/4ST__HLF | 14.0 | 12.4 | 8.0 | 8.1 |
| 18 | SFV18R-3/4ST__HLF | 14.5 | 12.9 | 8.5 | 8.6 |
| 19 | SFV19R-3/4ST__HLF | 15.0 | 13.4 | 9.0 | 9.1 |
| 20 | SFV20R-3/4ST__HLF | 15.5 | 13.9 | 9.5 | 9.6 |
| 21 | SFV21R-3/4ST__HLF | 16.0 | 14.4 | 10.0 | 10.1 |
| 22 | SFV22R-3/4ST__HLF | 16.5 | 14.9 | 10.5 | 10.6 |
| 23 | SFV23R-3/4ST__HLF | 17.0 | 15.4 | 11.0 | 11.1 |
| 24 | SFV24R-3/4ST__HLF | 17.5 | 15.9 | 11.5 | 11.6 |
| 25 | SFV25R-3/4ST__HLF | 18.0 | 16.4 | 12.0 | 12.1 |
| 26 | SFV26R-3/4ST__HLF | 18.5 | 16.9 | 12.5 | 12.6 |
| 27 | SFV27R-3/4ST__HLF | 19.0 | 17.4 | 13.0 | 13.1 |
| 28 | SFV28R-3/4ST__HLF | 19.5 | 17.9 | 13.5 | 13.6 |
| 29 | SFV29R-3/4ST__HLF | 20.0 | 18.4 | 14.0 | 14.1 |
| 30 | SFV30R-3/4ST__HLF | 20.5 | 18.9 | 14.5 | 14.6 |
| 31 | SFV31R-3/4ST__HLF | 21.0 | 19.4 | 15.0 | 15.1 |
| 32 | SFV32R-3/4ST__HLF | 21.5 | 19.9 | 15.5 | 15.6 |
| 33 | SFV33R-3/4ST__HLF | 22.0 | 20.4 | 16.0 | 16.1 |
| 34 | SFV34R-3/4ST__HLF | 22.5 | 20.9 | 16.5 | 16.6 |
| 35 | SFV35R-3/4ST__HLF | 23.0 | 21.4 | 17.0 | 17.1 |

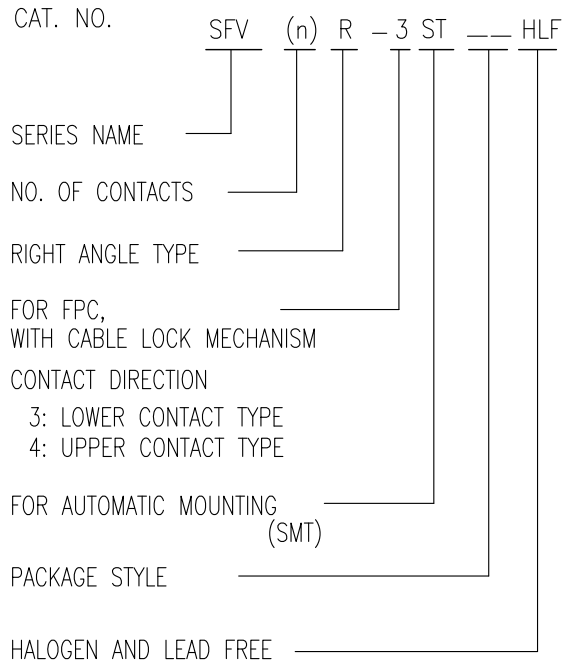

NOTES

1. THIS PRODUCT IS THE CONNECTOR USED FOR FPC AND COPES WITH AUTOMATIC MOUNTING (SMT).
2. SEE PART DRAWINGS FOR DIMENSIONS A~D.
3. THIS PRODUCT IS THE CONNECTOR WITH CABLE LOCK MECHANISM.

Amphenol FCI

© 2016 AFCl

| | | | | | | | | | |
|-------------|----------------|------------------|------|---------------------------------------|------------|------------|--------------|--|--|
| mat'l. code | | surface ISO 1302 | | tolerance ISO 406 ISO 1101 | | projection | | product family 58EF | |
| ltr | ecn no | dr | date | tolerances unless otherwise specified | | MM | | title | |
| B | | | | angles | linear | scale N/A | | CAT. NO. TABLE FOR 0.5 mm CONTACT SPACING CONNECTOR (Cat. No. : SFV__R-3/4ST__HLF) | |
| | | | | dr | S.WATANABE | 2019-3-6 | Amphenol FCI | dwg no sheet 2 of 8 size | |
| | | | | enr | S.WATANABE | 2019-3-6 | | 10117319 A4 | |
| | | | | chr | S-H.THIO | 2019-3-7 | | | |
| | | | | appd | Y.KAMEDA | 2019-3-7 | | type Product Customer Drawing | |
| sheet index | revision sheet | | | | | | | | |

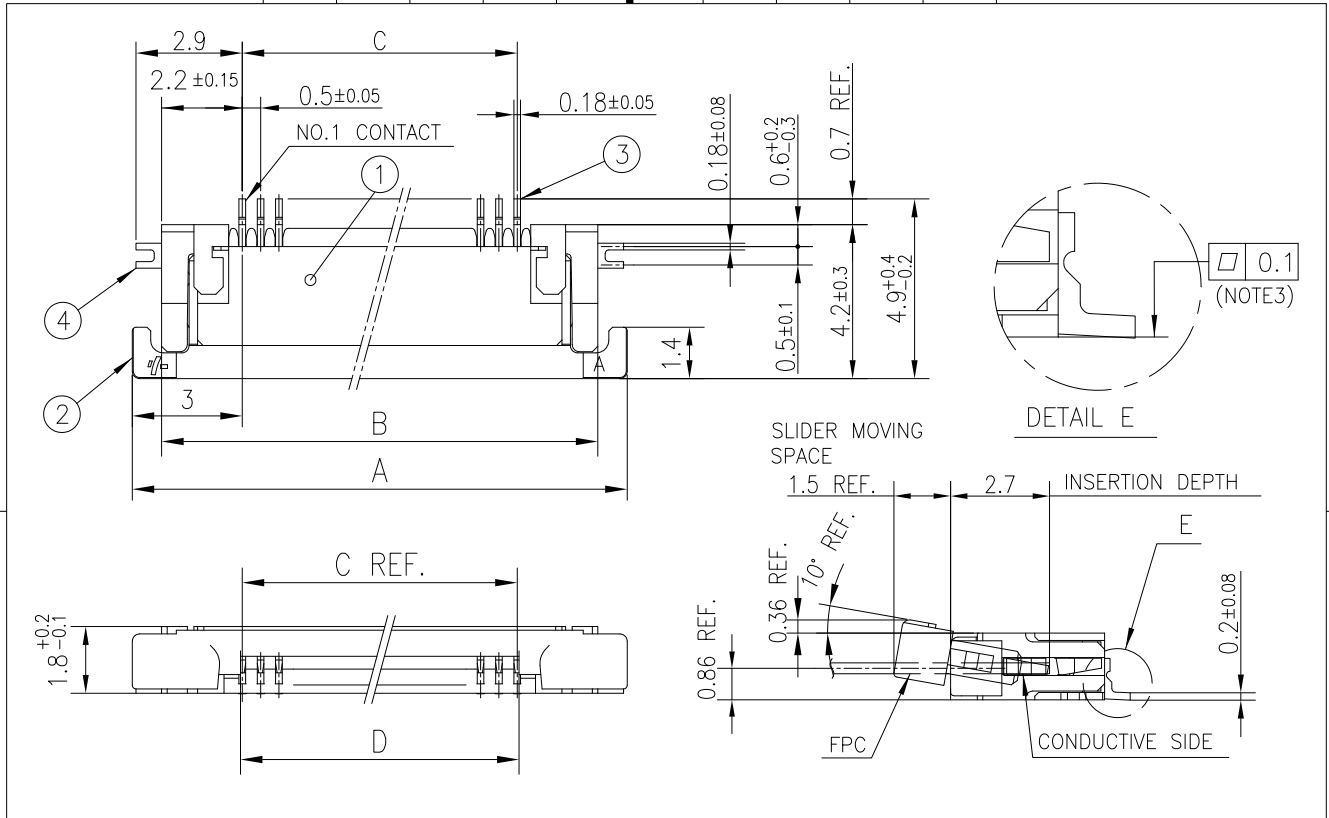

| PT. NO. | PARTS NAME | MATERIAL | Q'TY | NOTE |
|---------|----------------|--|------|--|
| 1 | HOUSING | 13~35pin : LCP RESIN GLASS REINFORCED (UL94V-0) | 1 | COLOR : BLACK (HALOGEN FREE) |
| | | 4~12pin : POLYAMIDE RESIN GLASS REINFORCED (UL94V-0) | | |
| 2 | SLIDER | PPS RESIN GLASS REINFORCED (UL94V-0) | 1 | COLOR : GRAY (HALOGEN FREE) |
| 3 | CONTACT | PHOSPHOR BRONZE | n | PLATING : MATTE PURE TIN Ni UNDER PLATED (LEAD FREE) |
| 4 | MOUNTING PLATE | | 2 | |

n : NO. OF CONTACTS

RECOMMENDED PC BOARD LAYOUT
(COMPONENT SIDE)

PATTERN FOR MOUNTING PLATE
FIXING

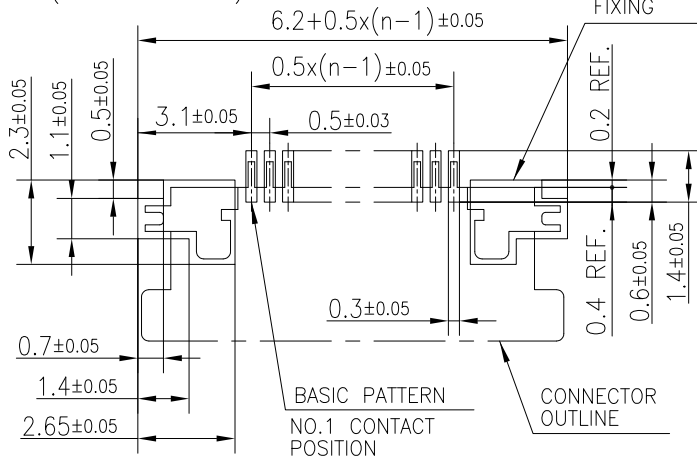

NOTES

- THIS PRODUCT IS THE CONNECTOR USED FOR FPC AND COPEs WITH AUTOMATIC MOUNTING (SMT).
- THIS PRODUCT IS LOWER CONTACT TYPE CONNECTOR WITH CABLE LOCK MECHANISM.
- FLATNESS OF CONTACT TERMINAL AND MOUNTING PLATE MUST BE WITHIN TOLERANCE IN E PORTION DETAILED DRAWING.
- THIS PRODUCT MEETS EUROPEAN UNION DIRECTIVES AND OTHER COUNTRY REGULATIONS AS DESCRIBED IN GS-22-008.
- THE HOUSING WILL WITHSTAND EXPOSURE TO 260°C PEAK TEMPERATURE FOR 10 SECONDS IN A REFLOW SOLDERING OVEN.

| | | | | | | | | | | | | |
|-------------|----------------|------------------|------|---------------------------------------|------------|------------|-------------------------------|---|----------|------|--|--------------|
| mat'l. code | | surface ISO 1302 | | tolerance ISO 406 ISO 1101 | | projection | | product family | | 58EF | | |
| ltr | ecn no | dr | date | tolerances unless otherwise specified | | MM | | title | | | | |
| B | | | | angles | linear | ±0.2 | | CONNECTOR USED FOR FPC WITH 0.5 mm CONTACT SPACING (Cat. No. : SFV__R-3ST__HLF) | | | | |
| | | | | dr | S.WATANABE | 2019-3-6 | scale N/A | | dwg no | | | sheet 3 of 8 |
| | | | | enr | S.WATANABE | 2019-3-6 | Amphenol FCI | | 10117319 | | | size |
| | | | | chr | S-H.THIO | 2019-3-7 | | | | | | A4 |
| | | | | appd | Y.KAMEDA | 2019-3-7 | type Product Customer Drawing | | | | | |
| sheet index | revision sheet | | | | | | | | | | | |

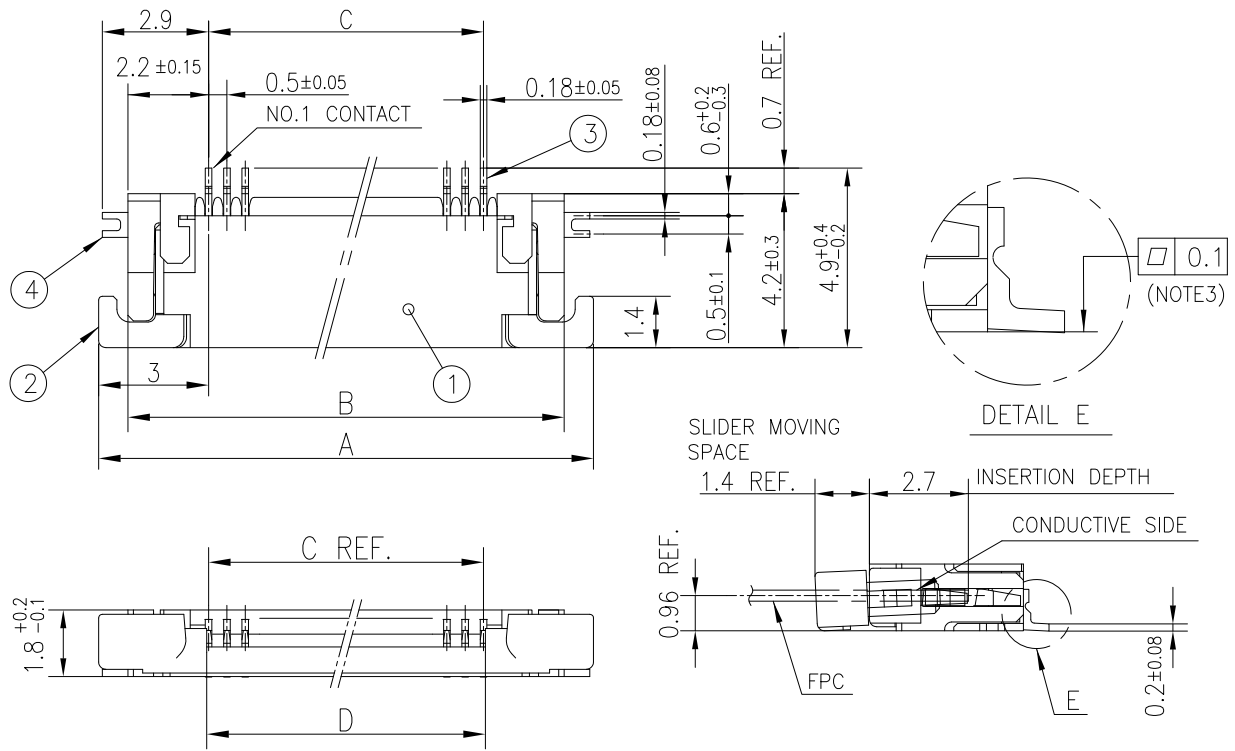

| PT. NO. | PARTS NAME | MATERIAL | Q'TY | NOTE |
|---------|----------------|--|------|--|
| 1 | HOUSING | 13~35pin : LCP RESIN GLASS REINFORCED (UL94V-0) | 1 | COLOR : BLACK (HALOGEN FREE) |
| | | 4~12pin : POLYAMIDE RESIN GLASS REINFORCED (UL94V-0) | | |
| 2 | SLIDER | PPS RESIN GLASS REINFORCED (UL94V-0) | 1 | COLOR : GRAY (HALOGEN FREE) |
| 3 | CONTACT | PHOSPHOR BRONZE | n | PLATING : MATTE PURE TIN Ni UNDER PLATED (LEAD FREE) |
| 4 | MOUNTING PLATE | | 2 | |

n : NO. OF CONTACTS

RECOMMENDED PC BOARD LAYOUT
(COMPONENT SIDE)

PATTERN FOR MOUNTING PLATE FIXING

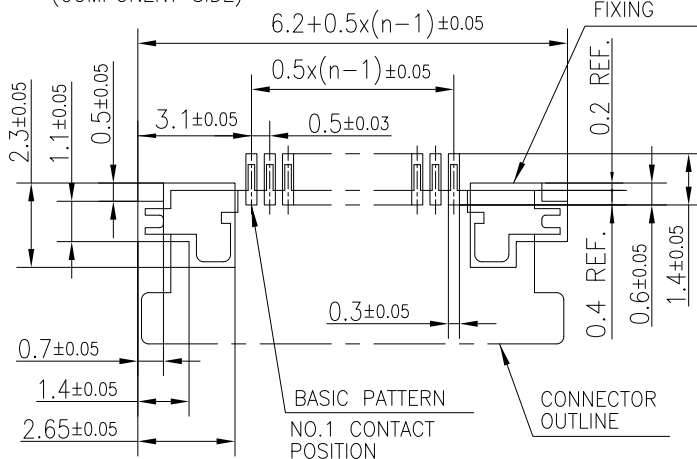

NOTES

- 1.THIS PRODUCT IS THE CONNECTOR USED FOR FPC AND COPES WITH AUTOMATIC MOUNTING (SMT).
- 2.THIS PRODUCT IS UPPER CONTACT TYPE CONNECTOR WITH CABLE LOCK MECHANISM.
- 3.FLATNESS OF CONTACT TERMINAL AND MOUNTING PLATE MUST BE WITHIN TOLERANCE IN E PORTION DETAILED DRAWING.
- 4.THIS PRODUCT MEETS EUROPEAN UNION DIRECTIVES AND OTHER COUNTRY REGULATIONS AS DESCRIBED IN GS-22-008.
- 5.THE HOUSING WILL WITHSTAND EXPOSURE TO 260°C PEAK TEMPERATURE FOR 10 SECONDS IN A REFLOW SOLDERING OVEN.

| | | | | | | | | | | | |
|-------------|--------|------------------|------------|---------------------------------------|--------|--------------|--|---|--|--------------------------|--|
| mat'l. code | | surface ISO 1302 | | tolerance ISO 406 ISO 1101 | | projection | | product family | | 58EF | |
| ltr | ecn no | dr | date | tolerances unless otherwise specified | | MM | | title | | | |
| B | | | | angles | linear | scale N/A | | CONNECTOR USED FOR FPC WITH 0.5 mm CONTACT SPACING (Cat. No. : SFV__R-4ST__HLF) | | | |
| | | dr | S.WATANABE | 2019-3-6 | | Amphenol FCI | | dwg no | | sheet 4 of 8 | |
| | | enr | S.WATANABE | 2019-3-6 | | | | 10117319 | | A4 | |
| | | chr | S-H.THIO | 2019-3-7 | | | | | | | |
| | | appd | Y.KAMEDA | 2019-3-7 | | | | | | | |
| sheet index | | revision sheet | | | | | | type | | Product Customer Drawing | |

CAT. NO. & DIMENSIONS

| NO. OF CONTACTS (n) | CAT. NO. | DIMENSIONS (NOTE3) | | |
|---------------------|-------------------|--------------------|---------|---------|
| | | F ± 5 | G ± 0.3 | H ± 0.1 |
| 4 | SFV 4R-3/4STE1HLF | 20.4 | 16 | — |
| 5 | SFV 5R-3/4STE1HLF | 20.4 | 16 | — |
| 6 | SFV 6R-3/4STE1HLF | 20.4 | 16 | — |
| 7 | SFV 7R-3/4STE1HLF | 28.4 | 24 | — |
| 8 | SFV 8R-3/4STE1HLF | 28.4 | 24 | — |
| 9 | SFV 9R-3/4STE1HLF | 28.4 | 24 | — |
| 10 | SFV10R-3/4STE1HLF | 28.4 | 24 | — |
| 11 | SFV11R-3/4STE1HLF | 28.4 | 24 | — |
| 12 | SFV12R-3/4STE1HLF | 28.4 | 24 | — |
| 13 | SFV13R-3/4STE1HLF | 28.4 | 24 | — |
| 14 | SFV14R-3/4STE1HLF | 28.4 | 24 | — |
| 15 | SFV15R-3/4STE1HLF | 28.4 | 24 | — |
| 16 | SFV16R-3/4STE1HLF | 28.4 | 24 | — |
| 17 | SFV17R-3/4STE1HLF | 28.4 | 24 | — |
| 18 | SFV18R-3/4STE1HLF | 28.4 | 24 | — |
| 19 | SFV19R-3/4STE1HLF | 28.4 | 24 | — |
| 20 | SFV20R-3/4STE1HLF | 28.4 | 24 | — |
| 21 | SFV21R-3/4STE1HLF | 28.4 | 24 | — |
| 22 | SFV22R-3/4STE1HLF | 28.4 | 24 | — |
| 23 | SFV23R-3/4STE1HLF | 36.4 | 32 | 28.4 |
| 24 | SFV24R-3/4STE1HLF | 36.4 | 32 | 28.4 |
| 25 | SFV25R-3/4STE1HLF | 36.4 | 32 | 28.4 |
| 26 | SFV26R-3/4STE1HLF | 36.4 | 32 | 28.4 |
| 27 | SFV27R-3/4STE1HLF | 36.4 | 32 | 28.4 |
| 28 | SFV28R-3/4STE1HLF | 36.4 | 32 | 28.4 |
| 29 | SFV29R-3/4STE1HLF | 36.4 | 32 | 28.4 |
| 30 | SFV30R-3/4STE1HLF | 36.4 | 32 | 28.4 |
| 31 | SFV31R-3/4STE1HLF | 48.4 | 44 | 40.4 |
| 32 | SFV32R-3/4STE1HLF | 48.4 | 44 | 40.4 |
| 33 | SFV33R-3/4STE1HLF | 48.4 | 44 | 40.4 |
| 34 | SFV34R-3/4STE1HLF | 48.4 | 44 | 40.4 |
| 35 | SFV35R-3/4STE1HLF | 48.4 | 44 | 40.4 |

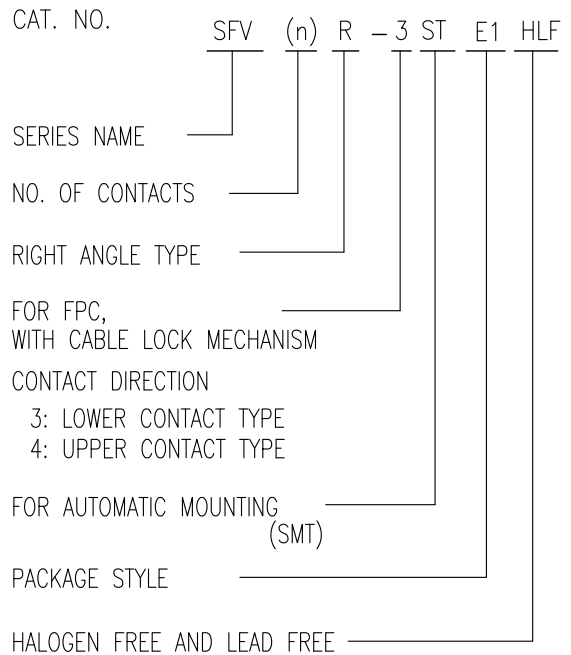

NOTES

1. THIS PRODUCT IS THE CONNECTOR USED FOR FPC AND COPES WITH AUTOMATIC MOUNTING (SMT).
2. THIS CATALOG NO. INDICATES PLASTIC TAPE PACKAGED
3. SEE PART DRAWINGS FOR DIMENSIONS F~H.
4. THIS PRODUCT IS THE CONNECTOR WITH CABLE LOCK MECHANISM.

Amphenol FCI

© 2016 AFCl

| | | | | | | | | | |
|-------------|----------------|--|------|----------------------------|---------------------------------------|------------|--|---------------------|-------------------------------|
| mat'l. code | | surface ISO 1302 <input checked="" type="checkbox"/> | | tolerance ISO 406 ISO 1101 | | projection | | product family 58EF | |
| ltr | ecn no | dr | date | | tolerances unless otherwise specified | | title | | |
| B | | | | | angles linear | | CAT. NO. TABLE FOR PLASTIC TAPE PACKAGED 0.5 mm CONTACT SPACING CONNECTOR (Cat. No. : SFV__R-3/4STE1HLF) | | |
| | | | dr | S.WATANABE | 2019-3-6 | | scale N/A | | |
| | | | enr | S.WATANABE | 2019-3-6 | | | | dwg no sheet 5 of 8 size |
| | | | chr | S-H.THIO | 2019-3-7 | | | | 10117319 A4 |
| | | | appd | Y.KAMEDA | 2019-3-7 | | | | type Product Customer Drawing |
| sheet index | revision sheet | | | | | | | | |

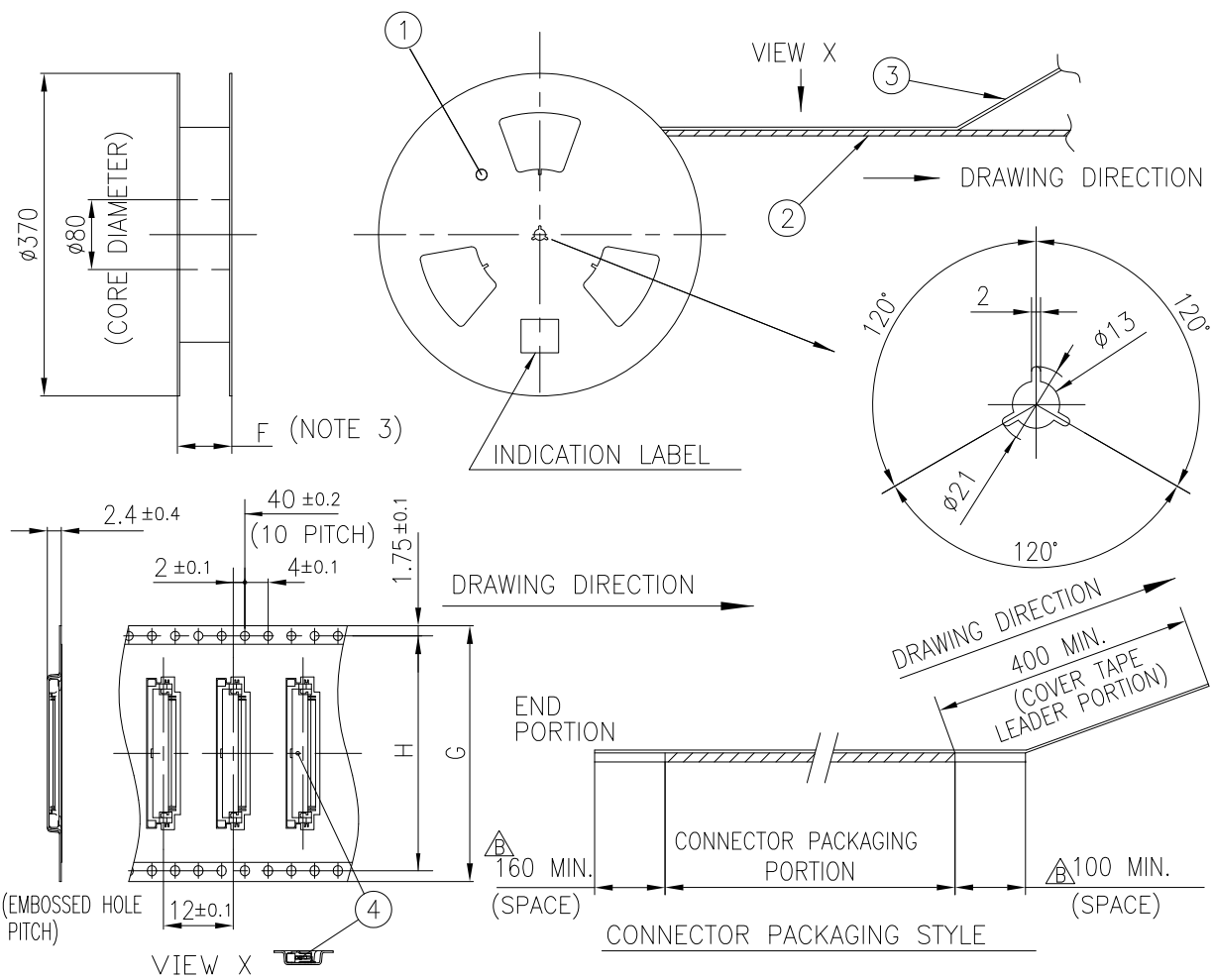

| PT. NO. | PARTS NAME | CAT. NO. | MATERIAL | Q'TY | NOTE |
|---------|-----------------------|-----------------|--------------------------|-------|--|
| 1 | REEL | _____ | CARDBOARD | 1 | COLOR : WHITE |
| 2 | PLASTIC (EMBOSS) TAPE | _____ | △ PS or A-PET | _____ | COLOR : TRANSPARENCY |
| 3 | COVER | _____ | △ POLYESTER,POLYETHYLENE | _____ | COLOR : TRANSPARENCY |
| 4 | CONNECTOR | SFV__R-3ST__HLF | SEE SHEET 3 | 3000 | LOWER CONTACT TYPE WITH CABLE LOCK MECHANISM |

NOTES

1. THIS IS PLASTIC TAPE PACKAGED CONNECTOR USED FOR FPC AND COPES WITH AUTOMATIC MOUNTING (SMT).
2. SEE JIS C 0806 (PACKING OF ELECTRONIC COMPONENTS ON CONTINUOUS TAPES (SURFACE MOUNTING DEVICES)) FOR SHAPE AND DIMENSIONS OF PLASTIC (EMBOSS) TAPE AND REEL.
3. F DIMENSION IS PORTION OF THE CORE.

| | | | | | | | | | |
|-------------|----------------|--------------------|------|---------------------------------------|---------------------|--------------|--|---|--|
| mat'l. code | | surface ISO 1302 ✓ | | tolerance ISO 406 ISO 1101 | | projection | | product family 58EF | |
| ltr | ecn no | dr | date | tolerances unless otherwise specified | | MM | | title | |
| B | | | | angles | ±5 | scale N/A | | PLASTIC TAPE PACKAGED 0.5 mm CONTACT SPACING CONNECTOR (Cat. No. : SFV__R-3STE1HLF) | |
| | | | | linear | ±5 | Amphenol FCI | | dwg no sheet 6 of 8 size | |
| | | | | dr | S.WATANABE 2019-3-6 | | | 10117319 A4 | |
| | | | | enr | S.WATANABE 2019-3-6 | | | | |
| | | | | chr | S-H.THIO 2019-3-7 | | | | |
| | | | | appd | Y.KAMEDA 2019-3-7 | | | type Product Customer Drawing | |
| sheet index | revision sheet | | | | | | | | |

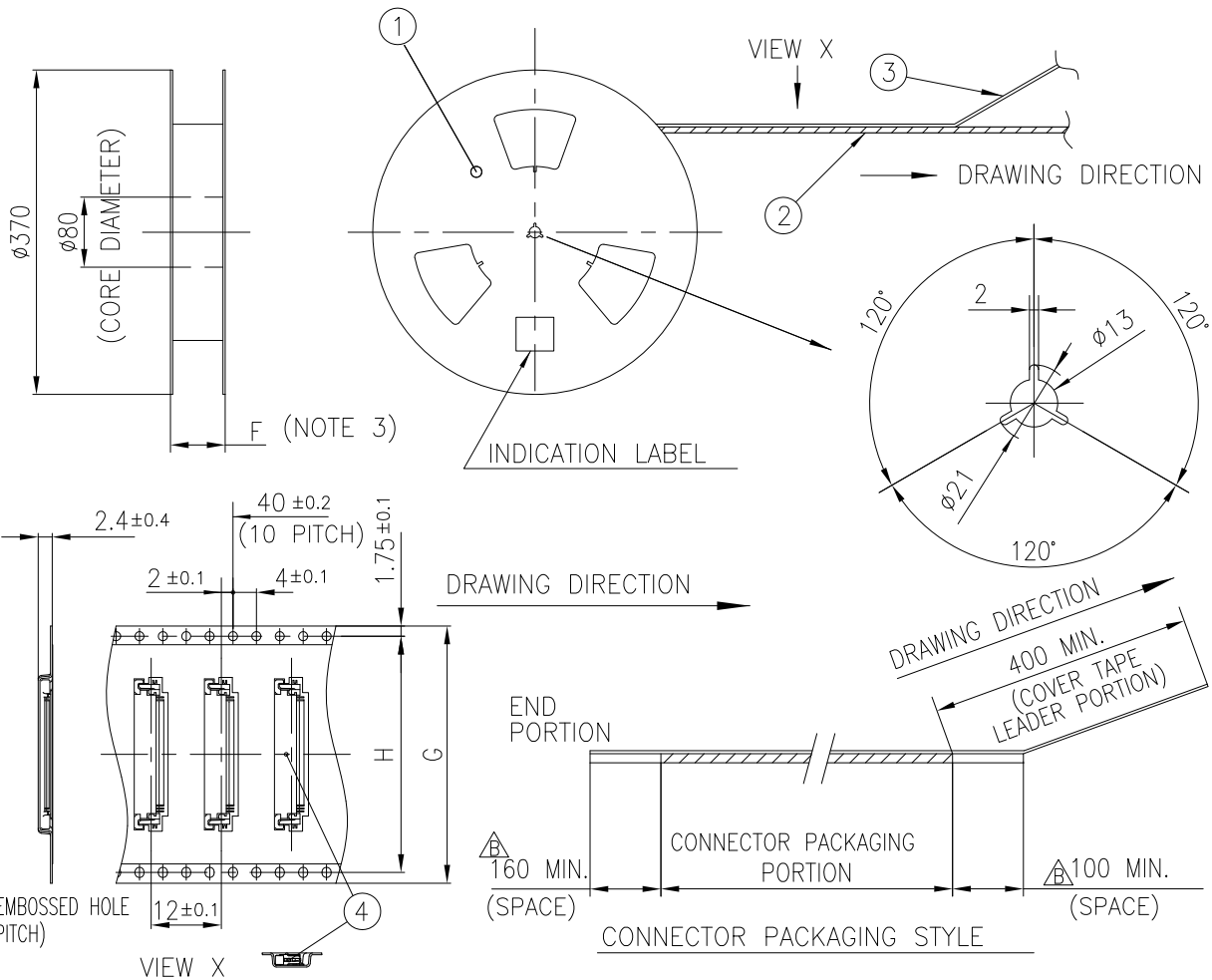

| PT. NO. | PARTS NAME | CAT. NO. | MATERIAL | Q'TY | NOTE |
|---------|-----------------------|-----------------|--------------------------|-------|--|
| 1 | REEL | _____ | CARDBOARD | 1 | COLOR : WHITE |
| 2 | PLASTIC (EMBOSS) TAPE | _____ | △ PS or A-PET | _____ | COLOR : TRANSPARENCY |
| 3 | COVER | _____ | △ POLYESTER,POLYETHYLENE | _____ | COLOR : TRANSPARENCY |
| 4 | CONNECTOR | SFV__R-4ST__HLF | SEE SHEET 4 | 3000 | UPPER CONTACT TYPE WITH CABLE LOCK MECHANISM |

NOTES

1. THIS IS PLASTIC TAPE PACKAGED CONNECTOR USED FOR FPC AND COPES WITH AUTOMATIC MOUNTING (SMT).
2. SEE JIS C 0806 (PACKING OF ELECTRONIC COMPONENTS ON CONTINUOUS TAPES (SURFACE MOUNTING DEVICES)) FOR SHAPE AND DIMENSIONS OF PLASTIC (EMBOSS) TAPE AND REEL.
3. F DIMENSION IS PORTION OF THE CORE.

| | | | | | | | | | |
|-------------|----------------|--------------------|------|---------------------------------------|------------|--------------|-------------------------------|---|----|
| mat'l. code | | surface ISO 1302 ✓ | | tolerance ISO 406 ISO 1101 | | projection | | product family 58EF | |
| ltr | ecn no | dr | date | tolerances unless otherwise specified | | MM | | title | |
| B | | | | angles | ±5 | scale N/A | | PLASTIC TAPE PACKAGED 0.5 mm CONTACT SPACING CONNECTOR (Cat. No. : SFV__R-4STE1HLF) | |
| | | | | ±5° | linear | Amphenol FCI | | dwg no sheet 7 of 8 size | |
| | | | | dr | S.WATANABE | 2019-3-6 | 10117319 | | △4 |
| | | | | enr | S.WATANABE | 2019-3-6 | type Product Customer Drawing | | |
| | | | | chr | S-H.THIO | 2019-3-7 | | | |
| | | | | appd | Y.KAMEDA | 2019-3-7 | | | |
| sheet index | revision sheet | | | | | | | | |

RECOMMENDED CABLE (FPC)

n : NO. OF CONTACTS

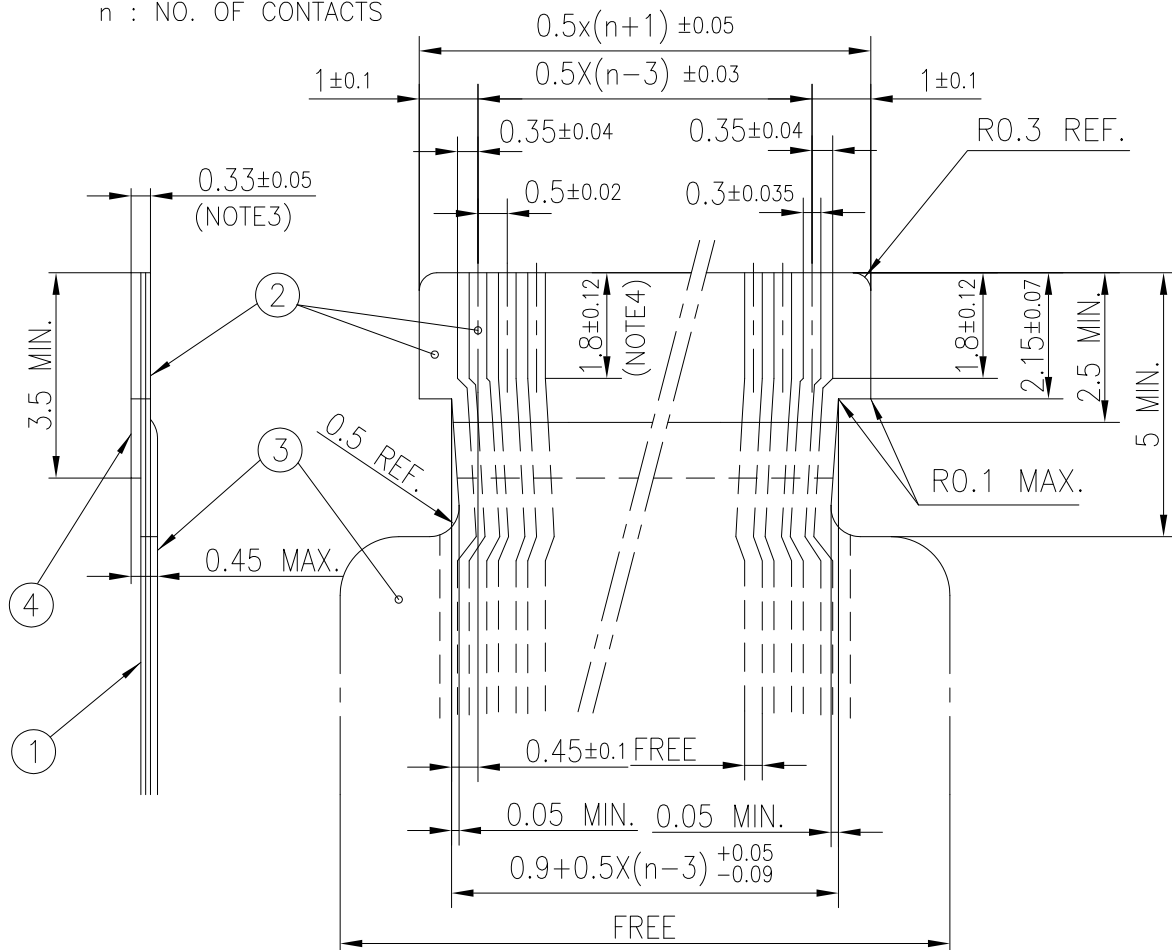

| PT. NO. | PARTS NAME | MATERIAL | THICKNESS (um) |
|---------|-----------------|---|----------------|
| 1 | BASE FILM | POLYIMIDE OR POLYESTER OR EQUAL | 25 |
| 2 | CONDUCTOR | COPPER FOIL(PLATING : TIN or SOLDER 1um min.) | 35 |
| 3 | OVERLAY | POLYIMIDE OR POLYESTER OR EQUIVARENT | — |
| 4 | SUPPORTING TAPE | POLYESTER OR POLYIMIDE OR EQUIVARENT | 188 |

NOTES

1. NO BURR AT EACH PORTION.
2. NO PEELING IN COMMON USE.
3. TOTAL THICKNESS LIMIT OF EACH MATERIAL (INCLUDING ADHESIVE AGENT) IS SPECIFIED.
4. THIS DIMENSION INDICATES THE RANGE FOR 0.3±0.035 CONDUCTOR WIDTH.

| | | | | | | | |
|-------------|----------------|--|------|---------------------------------------|------------|--|--------------|
| mat'l. code | | surface 58 / tolerance ISO 1302 / ISO 406 ISO 1101 | | projection | | product family 58EF | |
| ltr | ecn no | dr | date | tolerances unless otherwise specified | | title | |
| B | | | | angles | linear | RECOMMENDED CABLE (Cat. No. : SFV__R-3/4ST__HLF) | |
| | | | | dr | S.WATANABE | 2019-3-6 | dwg no |
| | | | | enr | S.WATANABE | 2019-3-6 | sheet 8 of 8 |
| | | | | chr | S-H.THIO | 2019-3-7 | size |
| | | | | appd | Y.KAMEDA | 2019-3-7 | A4 |
| | | | | type Product Customer Drawing | | | |
| sheet index | revision sheet | | | | | | |