



RJ45 Integrated Connector

Gigabit, Single Port, Through Hole, LED's, Tab-Up

MODEL NUMBER
TIC-L047-11

- Meets IEEE 802.3 and ANSI X3.263
- Operating temperature: 0°C to +85°C
- Storage Temperature: -40°C to +85°C

Package Information			
Weight		Quantity	
weight/pcs (g)	weight/carton (kg)	quantity/tray (pcs)	quantity/carton (pcs)
TBD	TBD	TBD	TBD

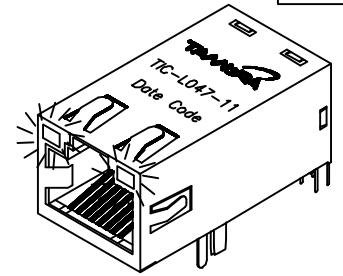

Electrical Specification @ 25°C										
Insertion Loss (dB Max)	Return Loss (dB Min)				CMRR (dB Min)	Crosstalk (dB Min)	OCL (μH Min)	Hipot (Vrms)	Impedance (Ω)	
1-100 MHz	1-30 MHz	60 MHz	80 MHz	100 MHz	1-100 MHz	1-100 MHz	8mA Dc Bias	1 minute		
-1	-18	-16	-12	-10	-30	-25	350	1500	100	

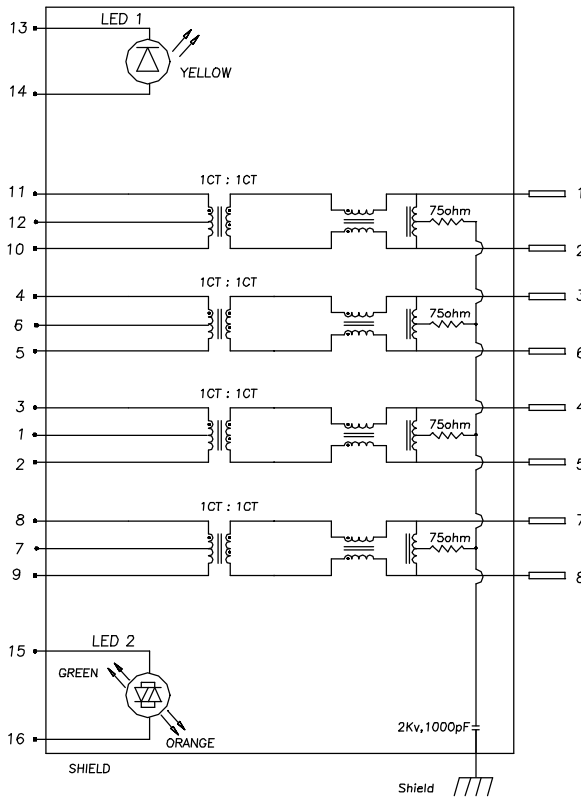

PREPARED BY:

D. Rund

ENGINEER:

L. Le

QUALITY CONTROL:

D. Kelley

APPROVED:

J. Coleman

DWG CONTROL NO.
P-A1-13085
ACAD\TIC\A1130851.DWG

REV
PRE

RJ45
INTEGRATED CONNECTOR

TAMURA CORPORATION OF AMERICA
43352 BUSINESS PARK DRIVE, TEMECULA, CA. 92590-6624
(909) 699-1270 FAX 9096769482

TIC-L047-11
MODEL SPECIFICATION

DIM: mm(in) SCL: NONE SH: 1 OF 2

PROPRIETARY NOTICE: THIS DRAWING PRINT OR DOCUMENT AND SUBJECT MATTER DISCLOSED HEREIN ARE PROPRIETARY ITEMS TO WHICH TAMURA RETAINS THE EXCLUSIVE RIGHT OF DISSEMINATION, REPRODUCTION, MANUFACTURE AND SALE. THIS DRAWING, PRINT OR DOCUMENT IS SUBMITTED IN CONFIDENCE FOR CONSIDERATION BY THE RECIPIENT ALONE UNLESS PERMISSION FOR FURTHER DISCLOSURE IS EXPRESSLY GRANTED IN WRITING.



RJ45 Integrated Connector

Gigabit, Single Port, Through Hole, LED's, Tab-Up

Mechanical Material Specification

Contact											Shell	
Contact Finish												
RJ Contact				Link and Joint Contacts					Housing and Case	Front	Back	
Contact Material	Contact Area	Solder Tail	Under-plating	Link Contact Material	Joint Contact Material	Contact Area	Solder Tail Area	Under-plating				
Phosphor Bronze	Gold	Tin/Lead (9:1)	Nickel	Brass		Brass	Tin/Lead (9:1)	Nickel	Thermal-plastic	Brass Tin/Lead Nickel	Stainless SUS 304	Stainless SUS304 -1/2H
0.30mm thick	30μ" MIN	100μ" MIN	50-100μ" MIN	0.25mm thick	0.35mm thick	120μ" MIN	100μ" MIN	50-100μ" MIN	Black UL 94V-0	0.20mm thick	0.20mm thick	0.25mm thick

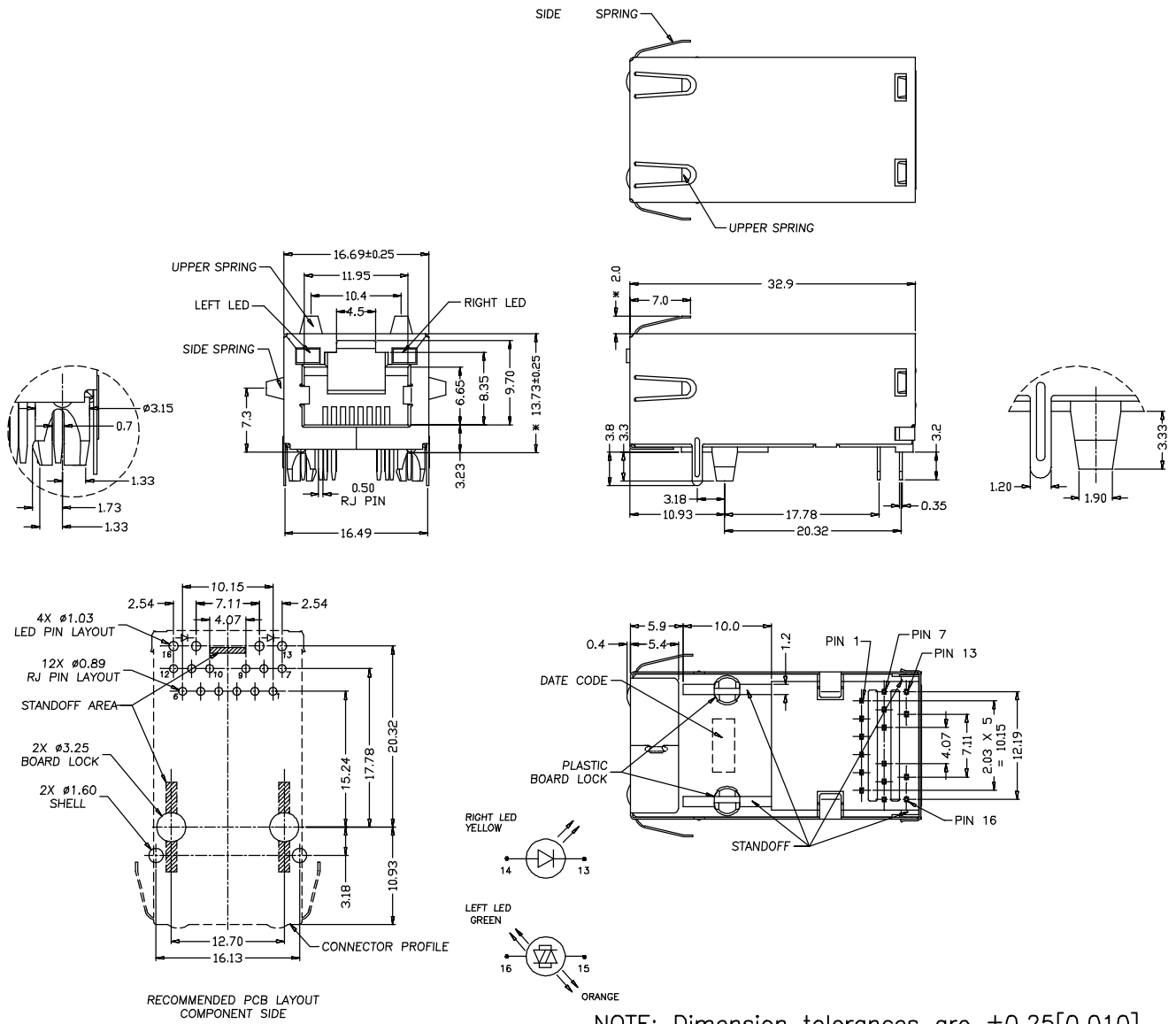

PREPARED BY:

D. Rund

ENGINEER:

L. Le

QUALITY CONTROL:

D. Kelley

APPROVED:

J. Coleman

DWG CONTROL NO. P-A1-13085
ACAD\TIC\A113085.DWG

REV PRE

RJ45 INTEGRATED CONNECTOR
TAMURA CORPORATION OF AMERICA
43352 BUSINESS PARK DRIVE, TEMECULA, CA. 92590-6624
(909) 699-1270 FAX 9096769482

TIC-L047-11
MODEL SPECIFICATION
DIM: MM[IN] SCL: NONE SH: 2 OF 2

NOTE: Dimension tolerances are ±0.25[0.010]

PROPRIETARY NOTICE: THIS DRAWING PRINT OR DOCUMENT AND SUBJECT MATTER DISCLOSED HEREIN ARE PROPRIETARY ITEMS TO WHICH TAMURA RETAINS THE EXCLUSIVE RIGHT OF DISSEMINATION, REPRODUCTION, MANUFACTURE AND SALE. THIS DRAWING, PRINT OR DOCUMENT IS SUBMITTED IN CONFIDENCE FOR CONSIDERATION BY THE RECIPIENT ALONE UNLESS PERMISSION FOR FURTHER DISCLOSURE IS EXPRESSLY GRANTED IN WRITING.