

POL Evaluation Board

ROA 128 3836

User Guide

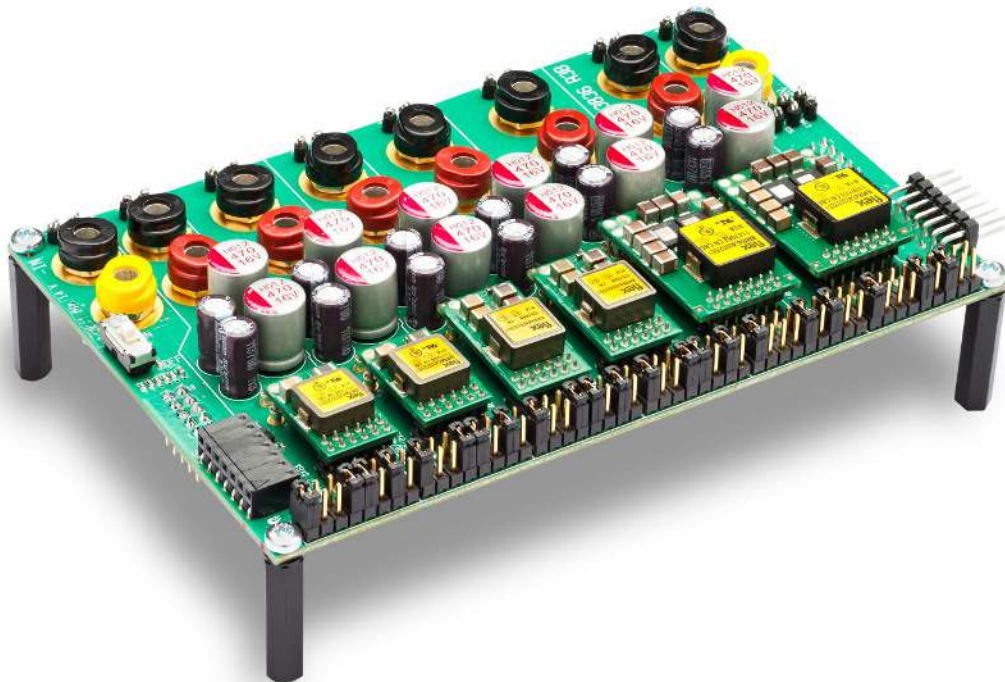

Contents

1	Schematics.....	3
2	Component layout	5
3	User Guide	6
3.1	Power Up/Down Instructions	6
3.1.1	Power Supply Connection	6
3.2	Jumper positions	9
3.2.1	Default settings.....	9
3.2.2	Jumper settings for BMR 450, 462, and 463.....	10
3.2.3	Jumper settings for BMR 451 and BMR 464.....	11
4	Address and vout range resistors	12
4.1	Change of address resistors	13
4.1.1	BMR 462/463 adjustment of address resistors	13
4.1.2	BMR 464 adjustment of address resistors	14
4.2	Change of Vout range resistors	15
4.2.1	BMR 462/463 adjustment of vout range resistors	15
4.2.2	BMR 464 adjustment of vout range resistors	16
5	Dimensions	17

1 Schematics

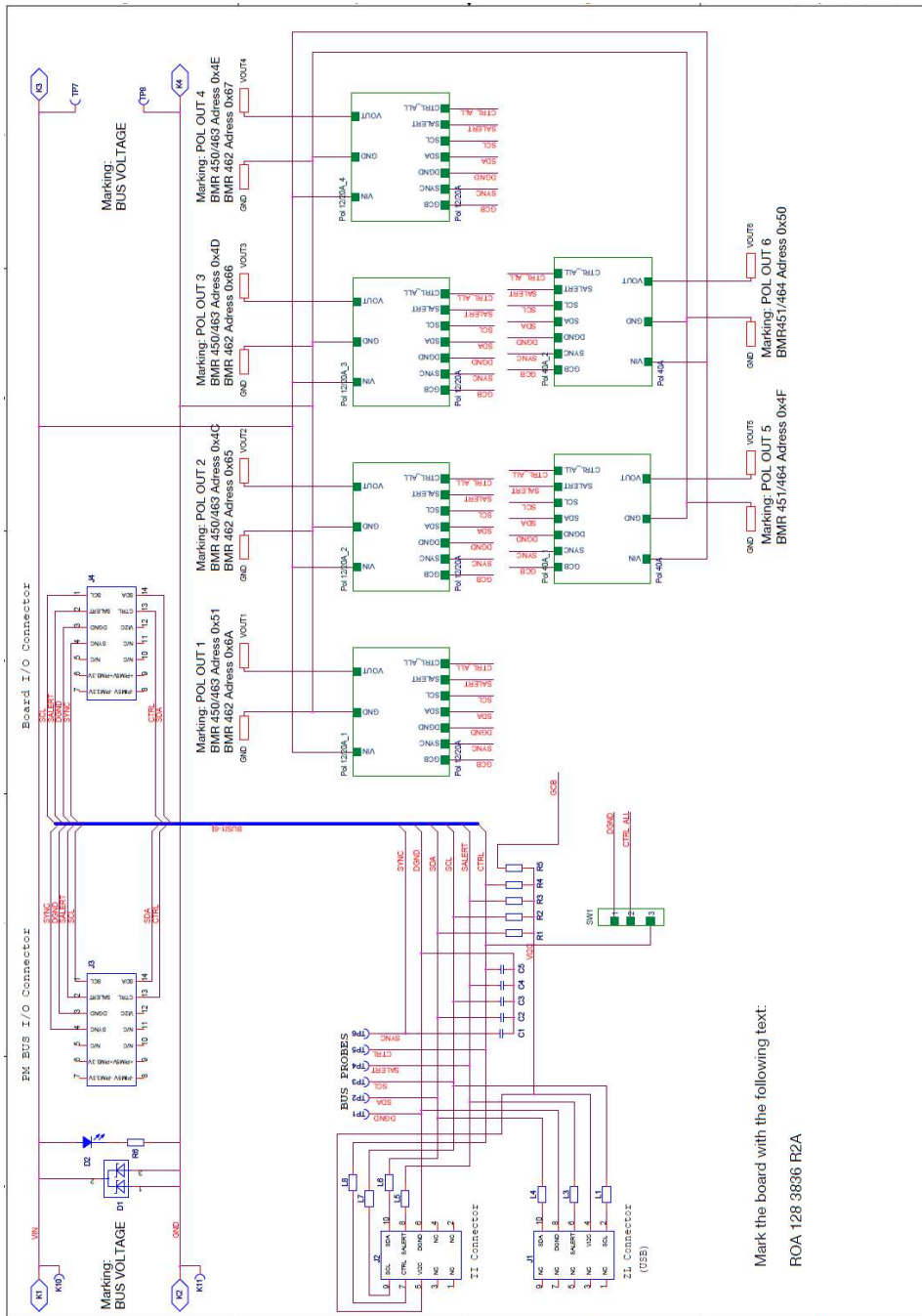

Mark the board with the following text:
ROA 128 3836 R2A

Fig 1.1 Top level schematics of ROA 128 3836

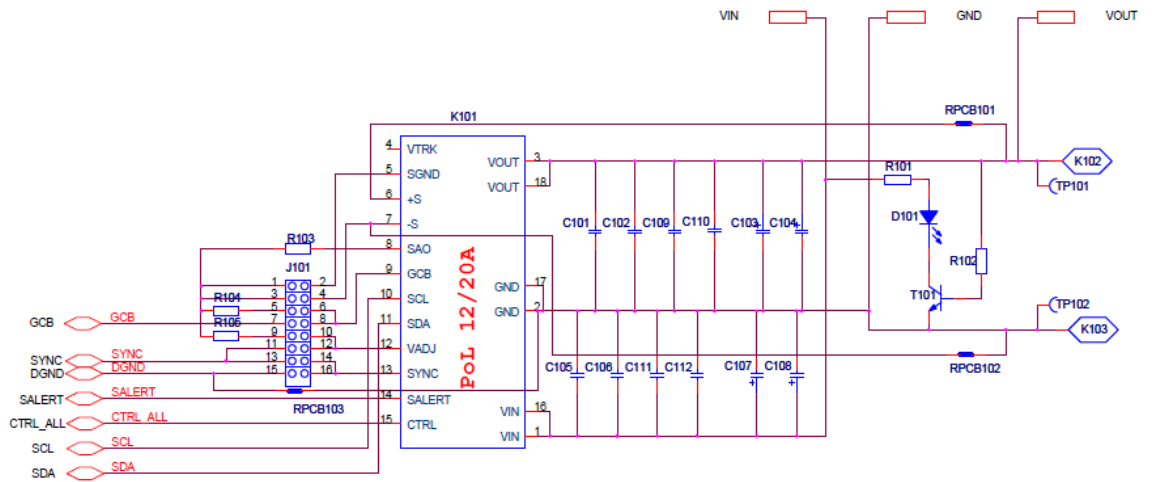

Fig 1.2 12A/20A POL schematics of ROA 128 3836

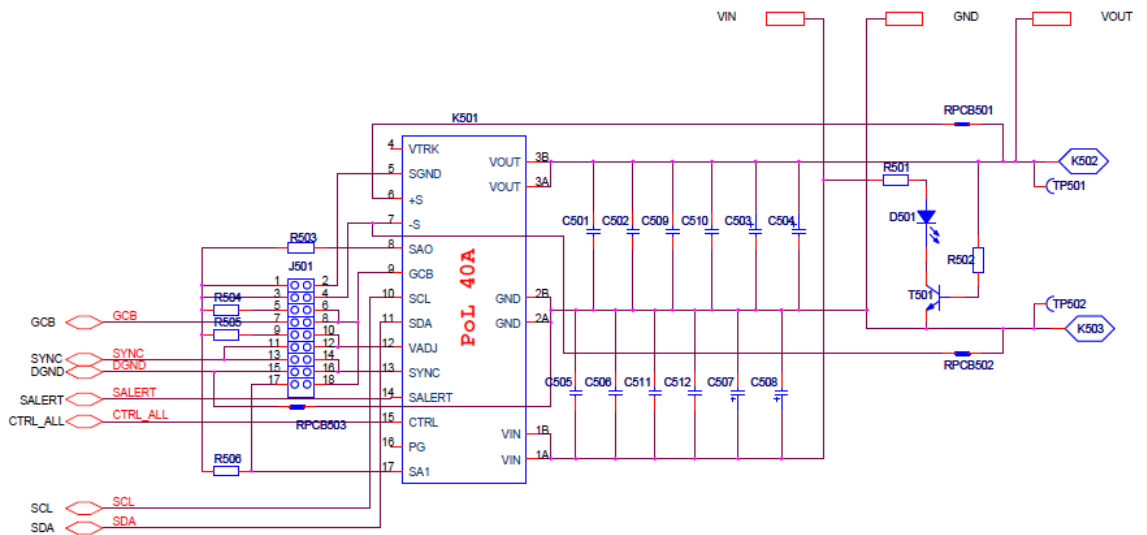

Fig 1.3 40A POL schematics of ROA 128 3836

2 Component layout

In Fig 2.1 and Fig 2.2 the component layout is shown.

Fig 2.1 Top side component layout of ROA 128 3836

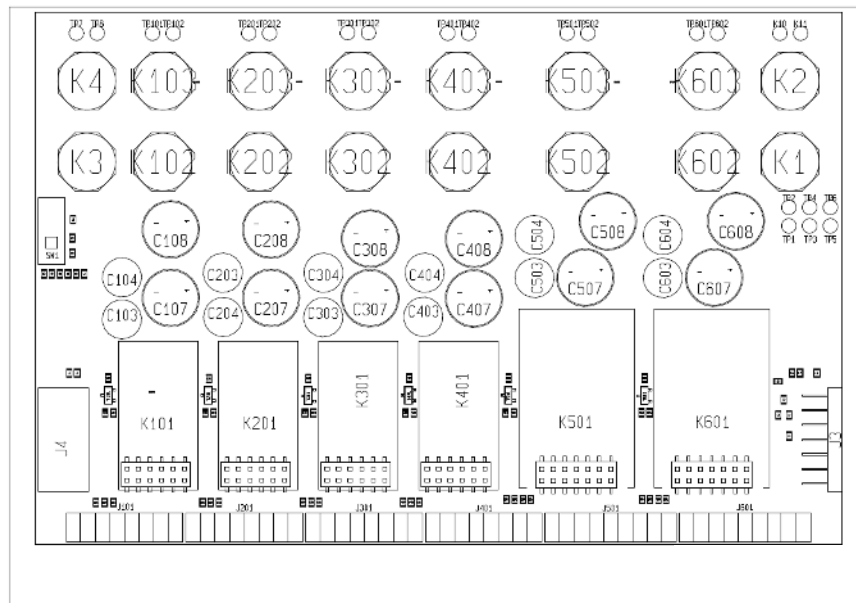
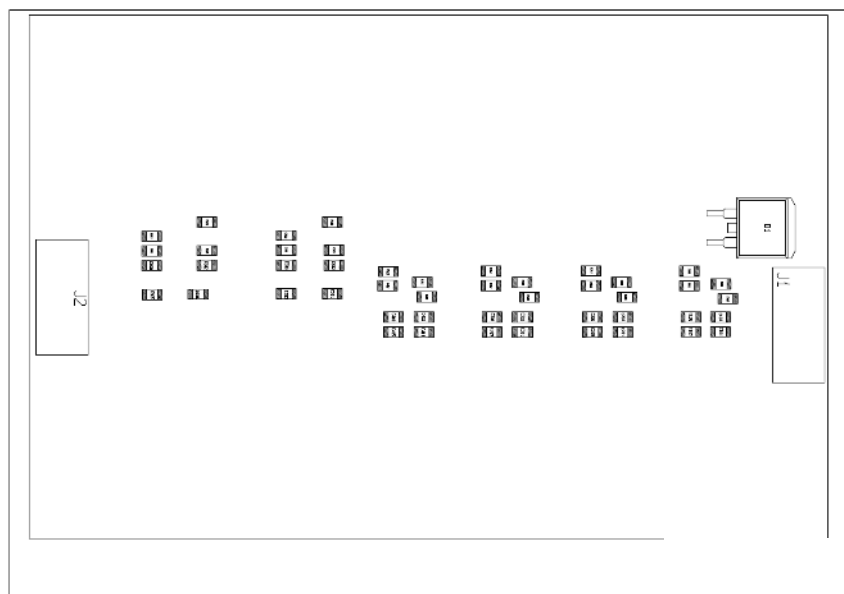

Fig 2.2 Bottom side component layout of ROA 128 3836



3 User Guide

3.1 Power Up/Down Instructions

This section of the document describes how to connect power supply for different cases in order to avoid mistake during measurements.

The jumpers that you need shall be mounted before power-up. See Sec 3.2 for information about jumper positions.

3.1.1 Power Supply Connection

Add the 5-14V DC power to the “**MAX 14V**” connectors (see Fig 3.1).

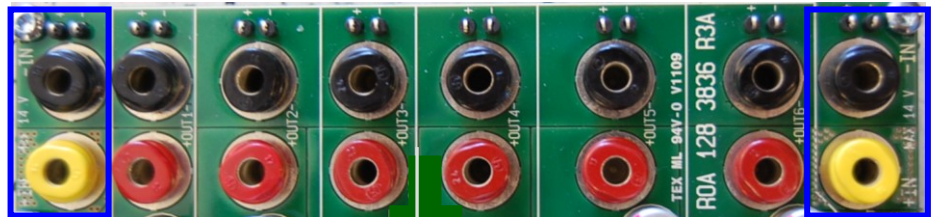

Fig 3.1 Connect 5-14V to either of the “Max 14V” DC power connectors located in both ends of the board (see blue rectangles).

Fig 3.2 shows the RC switch in “On” position.

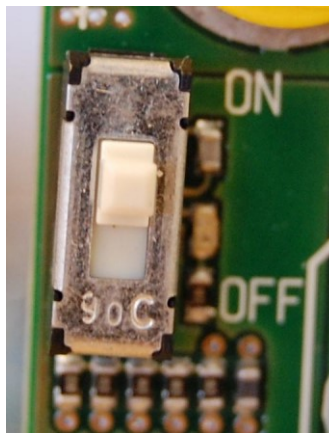

Fig 3.2 the RC switch in “On” position.

Fig 3.3a and Fig 3.3b shows the connection of two types of USB-to-PMBus adapters.

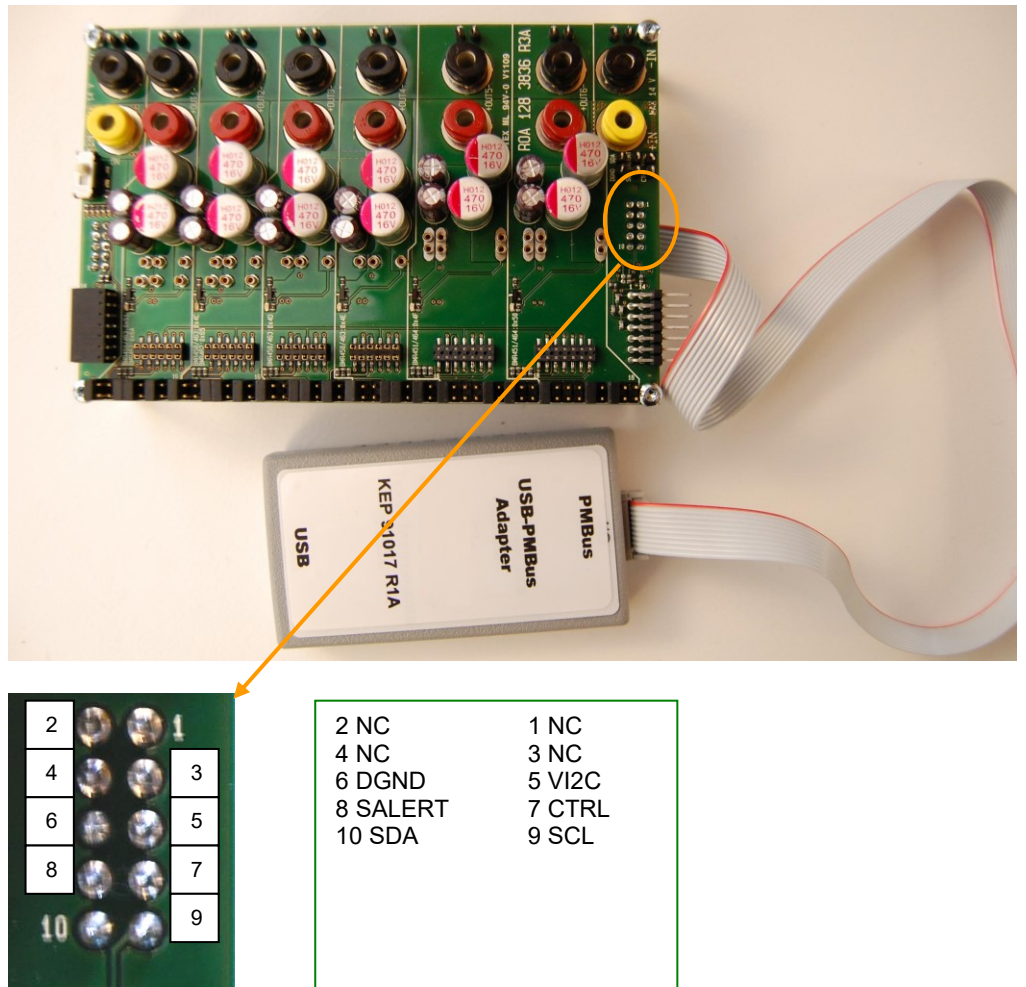

Fig 3.3a Connection of the Flex KEP 910 17 PMBus-to-USB adapter (connector is found on the back side of the ROA 128 3836 board)

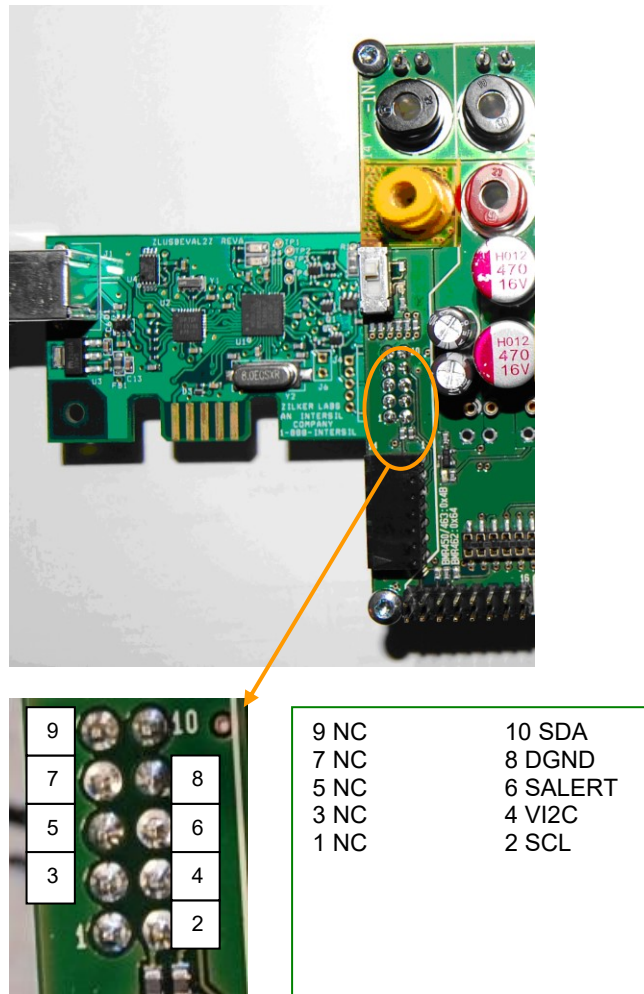

Fig 3.3b Connection of the Intersil ZLUSBREF02 PMBus-to-USB adapter (connector is found on the back side of the ROA 128 3836 board)

A. Power-up instruction:

- **Mount** the **BMRs** in the desired positions
- Connect and turn **On** the **5-14 V** supply
- Turn **RC switch** in **On** position
 - The LEDs should now give green light. (unless the outputs of the BMRs are not configured to be disabled).
- Connect the PMBus Adapter/Cable to the board.
- Start the software program.

B. Power-down instruction:

- Turn **RC switch** in **Off** position **or** turn **Off** the **5-14V** Supply
- Now, the **BMR** modules can be removed/replaced.

3.2 Jumper positions

3.2.1 Default settings

The factory default jumper positions are the shown in Fig 3.4.

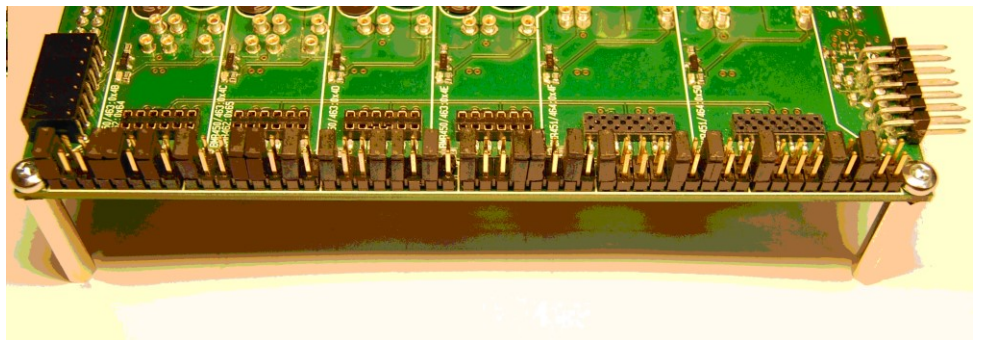

Fig 3.4 Factory default jumper settings of ROA 128 3836

3.2.2 Jumper settings for BMR 450, 462, and 463

In Fig 3.5 the jumper position numbers for BMR 450, 462 and 463 are given. Using Table 3.1, the User can make a custom configuration of the board.

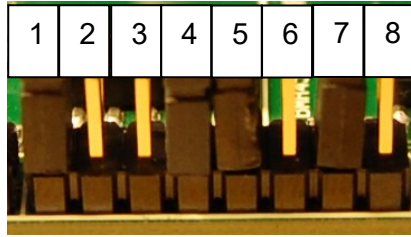

Fig 3.5. Position number of the jumpers for BMR 450, 462 and 463

Jumper Position No.	Description	Shall be used for	Notes
1	Address pin ground reference connection	BMR 462 BMR 463	Only one jumper in pos 1 or 2.
2	Address pin ground reference connection	BMR 450	
3	Connection to second address pin	BMR 450	Only one jumper in pos 3 or 4.
4	Connects module GCB pin to global GCB	BMR 462 BMR 463	
5	Vout_max limitation connection	BMR 450 BMR 462 BMR 463	Only one jumper in pos 5 or 6.
6	Connects module Sync to global Sync	BMR 450	
7	Connection module Sync to global Sync	BMR 462 BMR 463	Only one jumper in pos 7 or 8.
8	Shorts module Sync signal to GND/DGND	BMR 462 BMR 463	

Table 3.1. Description of jumper positions for BMR 450, 462 and 463.

3.2.3 Jumper settings for BMR 451 and BMR 464

In Fig 3.6 the jumper position numbers for BMR 451 and 464 are given. Using Table 3.2, the User can make a custom configuration of the board.

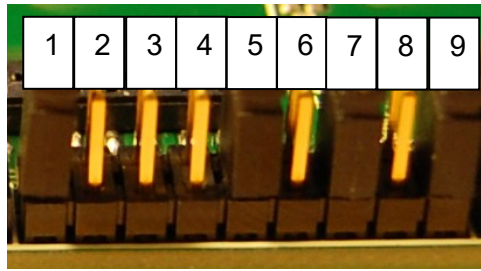

Fig 3.6. Position number of the jumpers for BMR 451 and 464

Jumper Position No.	Description	Shall be used for	Notes
1	Address pin ground reference connection	BMR 464	Only one jumper in pos 1 or 2.
2	Address pin ground reference connection	BMR 451	
3	N/A	-	Only one jumper in pos 3 or 4.
4	Connects module GCB pin to global GCB	BMR 464	
5	Vout_max limitation connection	BMR 451 BMR 464	Only one jumper in pos 5 or 6.
6	Connects module Sync to global Sync	BMR 451	
7	Connection module Sync to global Sync	BMR 464	Only one jumper in pos 7 or 8.
8	Shorts module Sync signal to GND/DGND	BMR 464	
9	Connection to second address pin	BMR 451	-

Table 3.2. Description of jumper positions for BMR 451 and 464

4 Address and vout range resistors

This section describes the locations of the Address and Vout-range pinstrap resistors. To know what resistor value to mount, please look in the actual technical specification of the BMR product.

Fig 4.1 shows the positions of the address and vout range resistors.

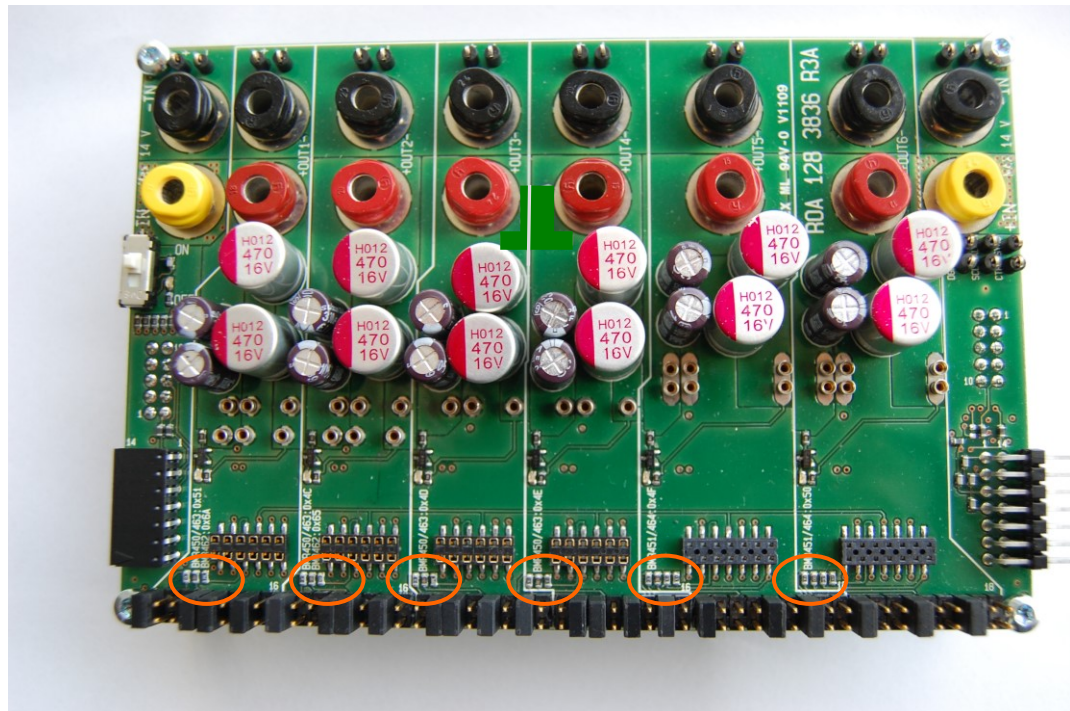

Fig 4.1 Positions of the address and vout range resistors.

4.1 Change of address resistors

4.1.1 BMR 462/463 adjustment of address resistors

To change the address in a position, change the R103, R203, R303 and R403 resistors values as shown in fig. 4.2.

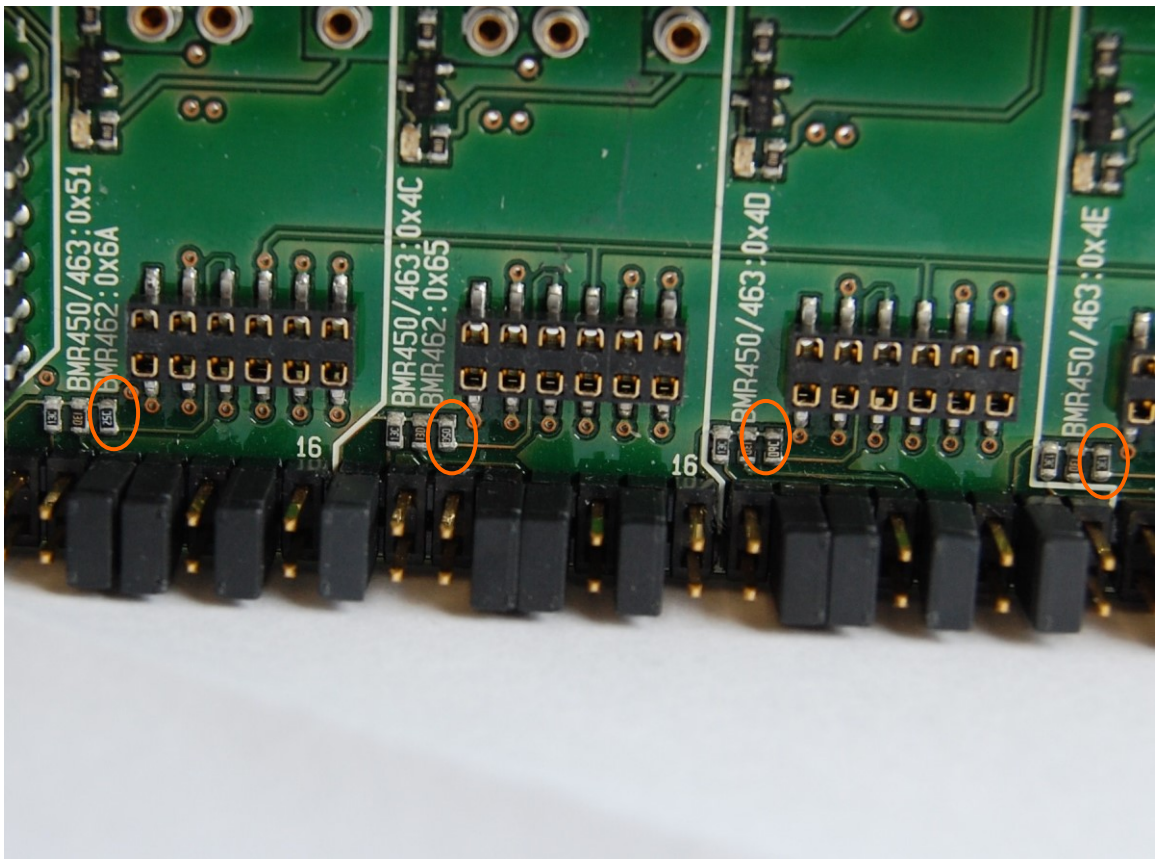

Fig 4.2 Address resistors in positions for BMR 462/463.

4.1.2 BMR 464 adjustment of address resistors

To change the address in a position, change the R503 and R603 resistors values as shown in fig. 4.3.

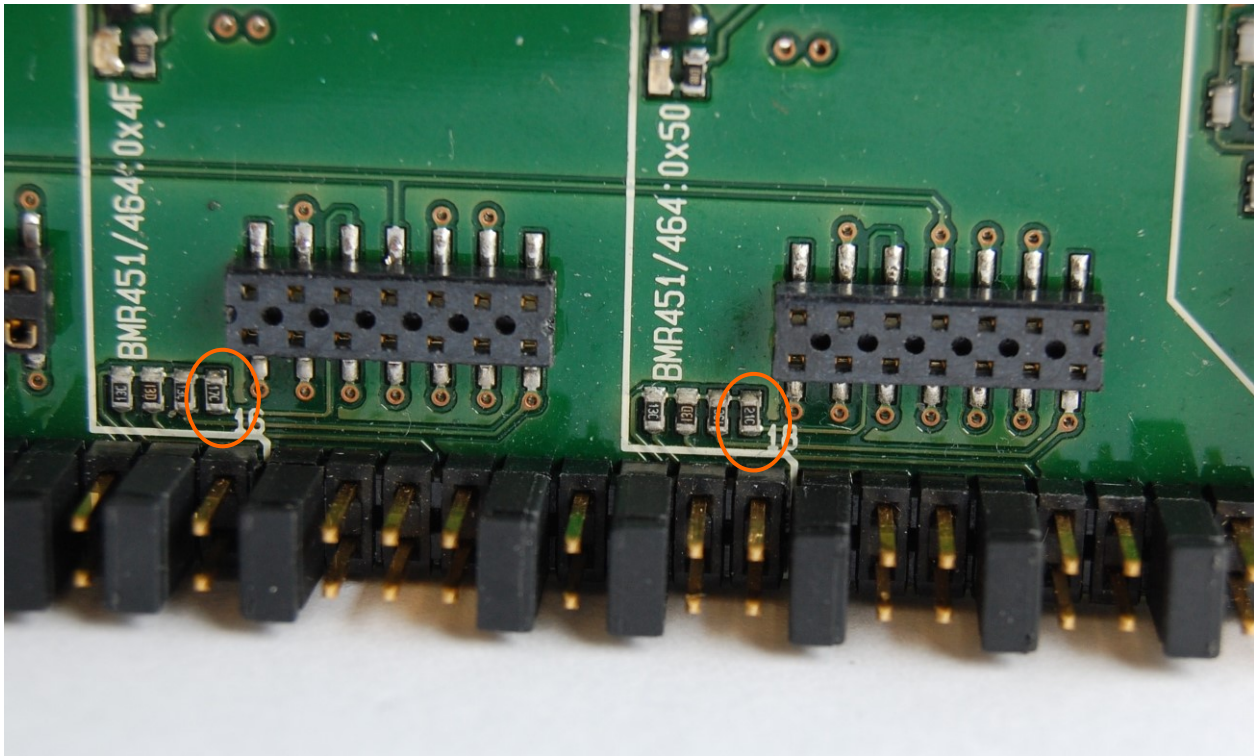

Fig 4.3 Address resistors in positions for BMR 464.

4.2 Change of Vout range resistors

4.2.1 BMR 462/463 adjustment of vout range resistors

To change the address in a position, change the R105, R205, R305 and R405 resistors values as shown in fig. 4.4.

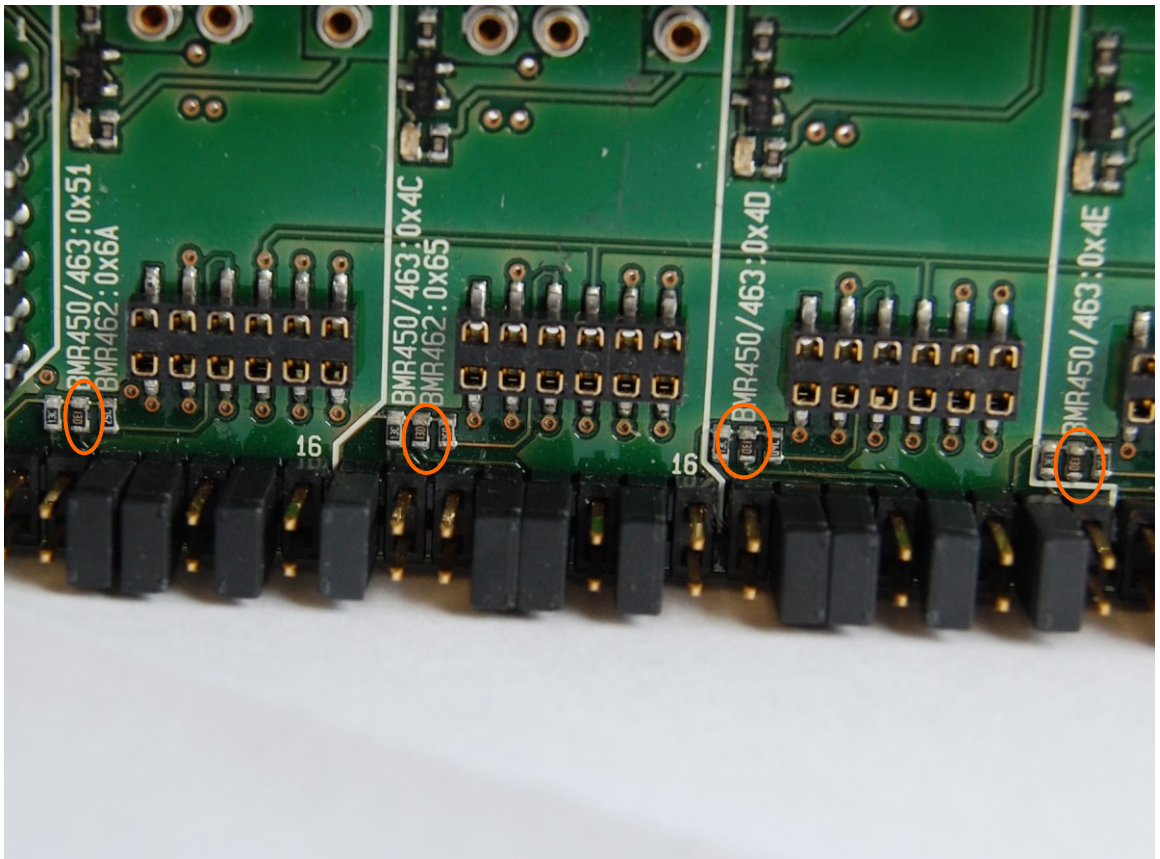

Fig 4.4 Vout range resistors in positions for BMR 462/463.

4.2.2 BMR 464 adjustment of Vout range resistors

To change the address in a position, change the R505 and R605 resistors values as shown in fig. 4.5.

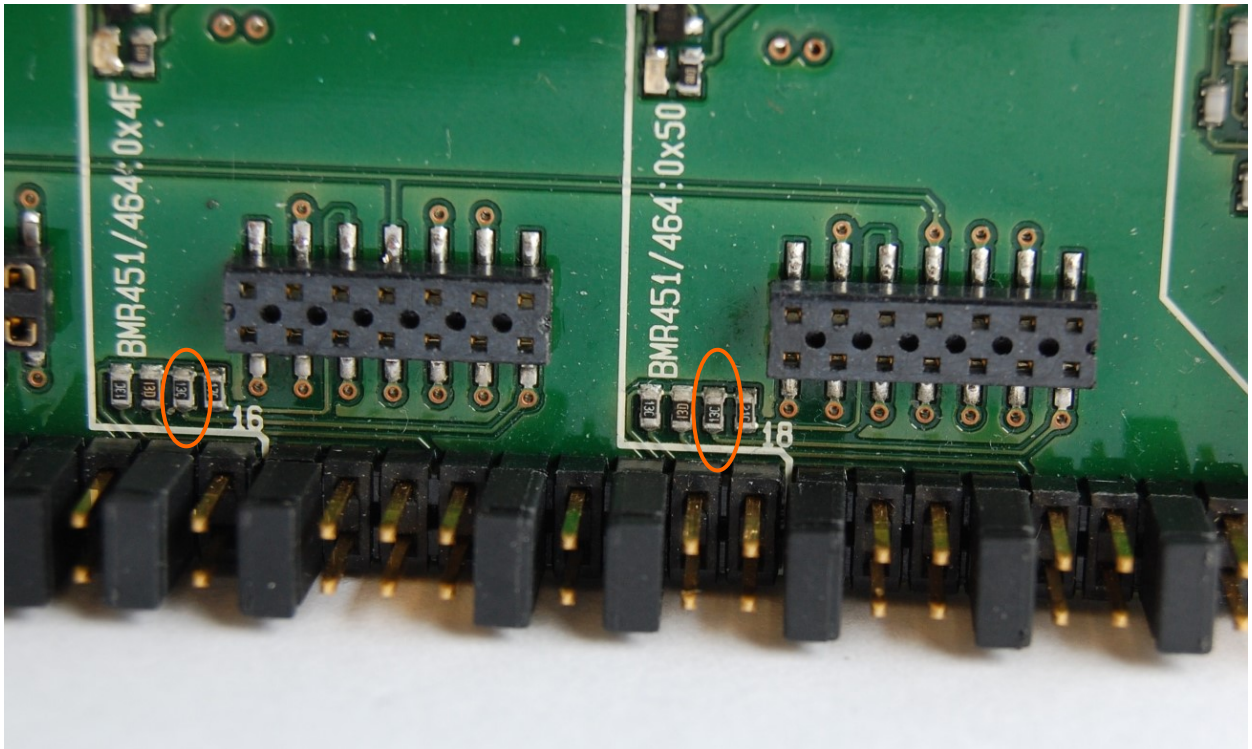

Fig 4.5 Vout range resistors in positions for BMR 464.

5 Dimensions

The outer dimensions (in mm) of the test board are shown in Fig 5.1.

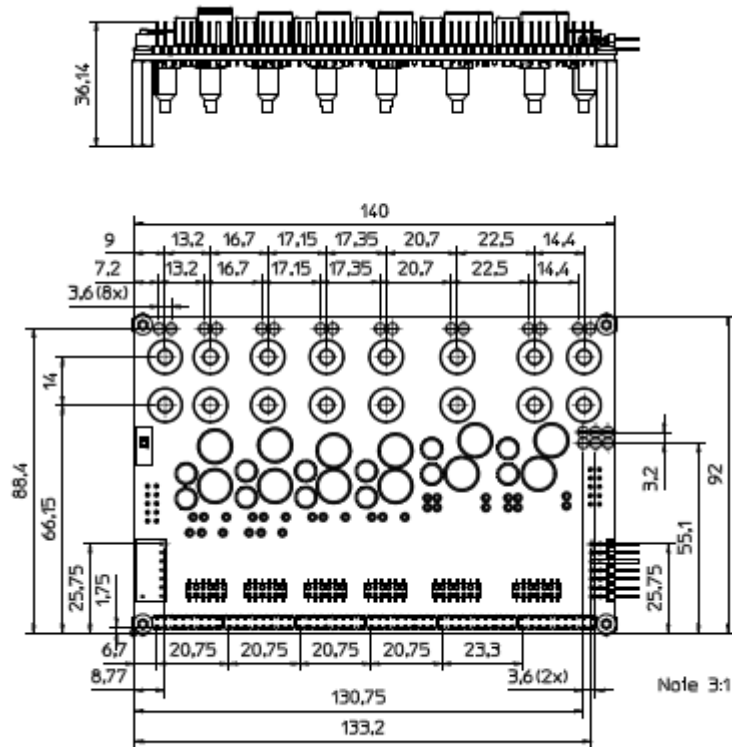

Fig 5.1 The outer dimensions (in mm).

The whole test board has the outer dimensions 133.2 x 92 x 36.14 mm (L x W x H). Weight of the complete test board including 24 jumpers is 193 g.