

DESCRIPTION: **RIGHT ANGLE .590" MALE PLASTIC D-SUB**

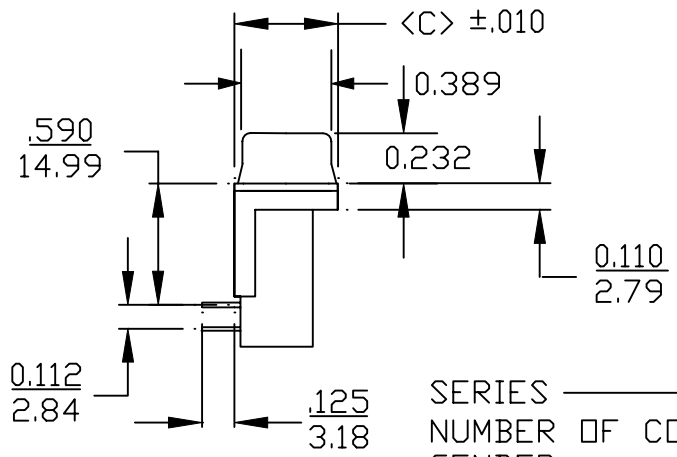
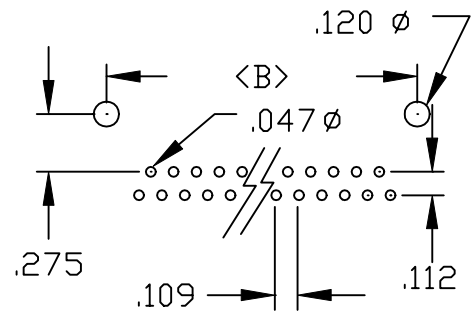
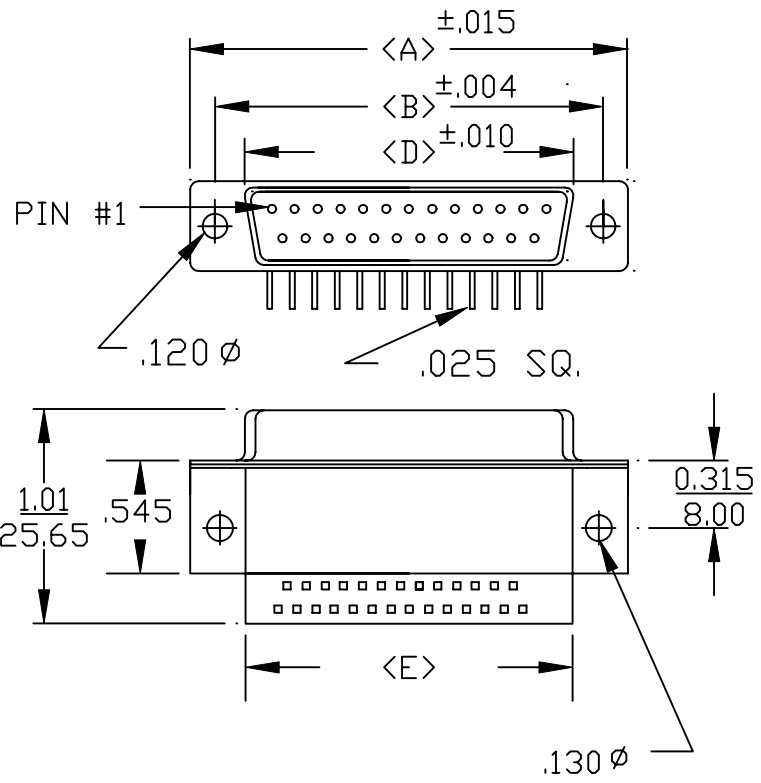

POS.	A	B	C	D	E
09	1.213	0.984	0.496	0.755	0.700
	30.80	24.99	12.60	19.18	17.78
15	1.543	1.312	0.496	1.081	1.402
	39.19	33.32	12.60	27.46	26.47
25	2.087	1.852	0.496	1.635	1.595
	53.00	47.04	12.60	41.53	40.51
37	2.732	2.500	0.496	2.264	2.231
	69.30	63.50	12.60	57.51	56.67

**SPECIFICATIONS:**

**MATERIALS:**

INSULATOR: UL 94V-0 RATED BLACK  
 GLASS FILLED POLYESTER  
 CONTACTS: PHOSPOR BRONZE - GOLD FLASH (STD)

**ELECTRICALS:**

CURRENT RATING: 5 AMPS  
 DIELECTRIC STRENGTH: 1000V AC RMS  
 INSULATION RESISTANCE: 1000 meg OHMS  
 CONTACT RESISTANCE: 10 MILLIOHMS MAX.  
 TEMPERATURE: -55°C TO +105°C

SERIES \_\_\_\_\_  
 NUMBER OF CONTACTS \_\_\_\_\_  
 GENDER: \_\_\_\_\_  
 1 = MALE  
 2 = FEMALE  
 PC MOUNT \_\_\_\_\_  
 SHELL MATERIAL \_\_\_\_\_  
 0 = ALL PLASTIC  
 2 = TIN SHELL  
 HARDWARE OPTIONS: \_\_\_\_\_  
 (SEE PAGE 2)  
 PLATING: \_\_\_\_\_  
 1 = GOLD FLASH  
 2 = 30 MICRO-INCH GOLD

177-XXX-11X-XX1

	THESE DRAWINGS AND SPECIFICATIONS ARE THE PROPERTY OF NorComp AND SHALL NOT BE REPRODUCED, COPIED OR USED AS THE BASIS FOR THE MANUFACTURE OR SALE OF APPARATUS WITHOUT WRITTEN PERMISSION.		DRAWN: <b>PAM JENKINS</b>	DATE: <b>9-23-98</b>
	<h1>NorComp</h1>			CHECKED:
SCALE:				SHEET <b>1</b> OF <b>2</b>
DWG NO.			<b>177-XXX-11X-XX1</b>	

DESCRIPTION: 177 SERIES HARDWARE

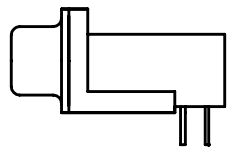
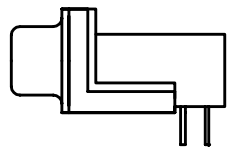
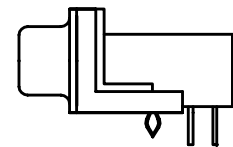
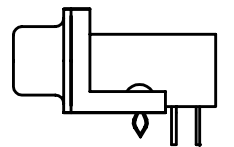
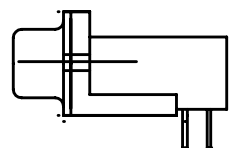
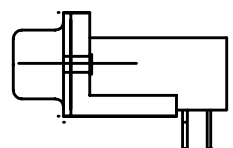
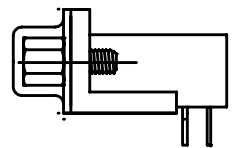
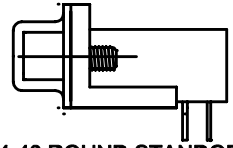
	 PLASTIC SHELL	 METAL SHELL WITH INSIDE GROUND STRAPS	 METAL SHELL WITH RETAINING CLIP GROUND	 PLASTIC SHELL WITH PLASTIC SNAP LOCK
 .120" DIA. HOLE	06	16	36	S6
 4-40 FLUSH INSERT	07	17	37	S7
 4-40 HEX STANDOFF FEMALE SCREWLOCK	08	18	38	S8
 4-40 ROUND STANDOFF FEMALE SCREWLOCK	09	19	39	S9 with washers



THESE DRAWINGS AND SPECIFICATIONS ARE THE PROPERTY OF NorComp AND SHALL NOT BE REPRODUCED, COPIED OR USED AS THE BASIS FOR THE MANUFACTURE OF SALE OF APPARATUS WITHOUT WRITTEN PERMISSION.

DRAWN:  
PAM JENKINS

DATE:  
11-3-98

CHECKED:

DATE:

# NorComp

SCALE: SHEET 2 OF 2 REV 3

DWG NO. 177 SERIES HARDWARE