

## PRODUCT SPECIFICATION

P/N: HMK325 B7225KN-T (X7R)

Type: Medium-High Voltage Multilayer Ceramic Capacitors

Soldering: Reflow only

Issue date: 28.Mar.2011

Applicable products to RoHS restriction

TAIYO YUDEN CO., LTD.

## 1. Scope

This specification covers multilayer chip type ceramic capacitor (Pb-Free) for use (for reflow soldering) in electronic appliances and electric communications equipment.

## 2. Part Numbering System

See page 8.

## 3. Test Conditions

Standard test conditions shall be temperature of 5 to 35°C, relative humidity of 45 to 85% and air pressure of 86 to 106kPa. Test shall be conducted at temperature of  $25 \pm 3^\circ\text{C}$ , relative humidity of 60 to 70% and air pressure of 86 to 106kPa if test result is suspectable.

Unless otherwise specified, all tests shall be conducted under standard test conditions.

## 4. Construction, Dimensions and Performance

Details of construction, dimensions and performance shall be specified in the following sheets.

## 5. Packaging

Packaging shall be made to avoid damages of capacitors during transportation or storage.

Packaging shall be marked with part number, quantity, lot number and manufacturer's name at its appropriate position.

For details, see page 10 to 12.

## 6. Manufacturing site

TAIYO YUDEN CO., LTD. (JAPAN)

KOREA KYONG NAM TAIYO YUDEN CO., LTD. (KOREA)

## 7. Precautions

•Please refer to precautions in our general catalog prior to product being used.

If you need further information, please contact us.

•CAUTION: This specification can't be assured when Sn-Zn lead free solder is used.

## 8. Storage conditions

To maintain the solderability of terminal electrodes and to keep the packaging material in good condition, care must be taken to control temperature and humidity in the storage area. Humidity should especially be kept as low as possible.

- Recommended conditions

Ambient temperature 30°C and below

Humidity 70% RH and below

The ambient temperature must be kept below 40°C. Even under ideal storage conditions capacitor electrode Solderability decreases as time passes, so ceramic chip capacitors should be used within 6 months from the time of delivery. If exceeding the above period, please check solderability before using the capacitors.

- The packaging material should be kept where no chlorine or sulfur exists in the air.

## 9. RoHS compliance

- This product conform to "RoHS compliance."
- "RoHS compliance" means that the product does not contain lead, cadmium, mercury, hexavalent chromium, PBB or PBDE referring to EU Directive 2002/95/EC, except other non-restricted substances or impurities which could not be technically removed at the refining process.

No.	Item	Specified Value	Remarks				
1	Operating Temperature Range	Capable of continuous operation under these conditions.	-55~+125°C				
2	Shape and Dimensions	Per Fig.1					
3	Heat Treatment		Initial value shall be measured after test sample is heat-treated at 150 +0/-10°C for an hour and kept at room temperature for 24±2 hours.				
4	Voltage Treatment		Initial value shall be measured after test sample is voltage-treated for an hour at temperature and voltage which are specified as test conditions, and kept at room temperature for 24±2 hours.				
5	Dielectric Withstanding Voltage (between terminals)	No abnormality.	Conforming to EIA RS-198-D (1991). 250% of DC rated voltage shall be applied for 1 to 5 seconds. Charging and discharging current shall be 50mA or less.				
6	Insulation Resistance	100M Ω · μ F min	Conforming to EIA RS-198-D (1991). Voltage to be measured shall be rated voltage and voltage applying time shall be 1 minute±5 seconds. Charging and discharging current shall be 50mA or less.				
7	Capacitance and Tolerance	2200000 pF ±10% (K) ±20% (M)	Conforming to EIA RS-198-D (1991). Heat treatment specified in No.3 of the specification shall be conducted prior to measurement. Measuring frequency and voltage shall conform to the table shown below. <table border="1" data-bbox="874 1205 1286 1305"> <thead> <tr> <th>Measuring Frequency</th> <th>Measuring Voltage</th> </tr> </thead> <tbody> <tr> <td>1kHz±10%</td> <td>1.0±0.2Vrms</td> </tr> </tbody> </table>	Measuring Frequency	Measuring Voltage	1kHz±10%	1.0±0.2Vrms
Measuring Frequency	Measuring Voltage						
1kHz±10%	1.0±0.2Vrms						
8	Dissipation Factor (tan δ)	3.5% max	Conforming to EIA RS-198-D (1991). Heat treatment specified in No.3 of the specification shall be conducted prior to measurement. Measuring frequency and voltage shall conform to the table shown below. <table border="1" data-bbox="874 1556 1286 1657"> <thead> <tr> <th>Measuring Frequency</th> <th>Measuring Voltage</th> </tr> </thead> <tbody> <tr> <td>1kHz±10%</td> <td>1.0±0.2Vrms</td> </tr> </tbody> </table>	Measuring Frequency	Measuring Voltage	1kHz±10%	1.0±0.2Vrms
Measuring Frequency	Measuring Voltage						
1kHz±10%	1.0±0.2Vrms						

No.	Item	Specified Value	Remarks										
9	Temperature Characteristic	$\pm 15\%$	Conforming to EIA RS-198-D (1991). Heat treatment specified in No.3 of the specification shall be conducted prior to measurement. Maximum capacitance deviation in both (+) and (-) sides in range of lowest temperature to highest temperature for capacitor shall be indicated in ratio of variation in reference to capacitance value at reference temperature.										
10	Adhesive Force of Terminal Electrodes	Terminal electrodes shall be no exfoliation or a sign of exfoliation.	Conforming to EIA RS-198-D (1991). Test sample shall be soldered to test board shown in Fig.2 and a force of 5N{0.51kgf} shall be applied in arrow direction for $30 \pm 5$ seconds.										
11	Vibration	Initial performance shall be satisfied.	Conforming to EIA RS-198-D (1991). Test sample shall be soldered to test board shown in Fig.2. Heat treatment specified in No.3 of the specification shall be conducted prior to test.  Test conditions: Frequency range: 10~55Hz Overall amplitude: 1.5mm Sweeping method: 10~55~10Hz for 1 min. Each two hours in X,Y,Z direction: 6 hours in total										
12	Resistance to Soldering Heat	Appearance	No abnormality	Conforming to EIA RS-198-D (1991). Test sample shall be completely submerged in molten solder of $270 \pm 5^\circ\text{C}$ for $3 \pm 0.5$ seconds. Preheating as shown in the table below shall be continuously conducted before submersion and test sample shall be kept at normal temperature after test. <table border="1" data-bbox="906 1283 1410 1424"> <thead> <tr> <th>Sequence</th> <th>Temperature (<math>^\circ\text{C}</math>)</th> <th>Time (min)</th> </tr> </thead> <tbody> <tr> <td>1</td> <td>80~100</td> <td>2 to 5</td> </tr> <tr> <td>2</td> <td>150~200</td> <td>2 to 5</td> </tr> </tbody> </table> Heat treatment specified in No.3 of the specification shall be conducted prior to test. Measurement shall be conducted after test sample is kept at room temperature for $24 \pm 2$ hours.	Sequence	Temperature ( $^\circ\text{C}$ )	Time (min)	1	80~100	2 to 5	2	150~200	2 to 5
		Sequence	Temperature ( $^\circ\text{C}$ )		Time (min)								
		1	80~100		2 to 5								
		2	150~200		2 to 5								
		Capacitance Change	Within $\pm 15.0\%$										
Dissipation Factor	3.5% max												
Insulation Resistance	Initial value shall be satisfied.												
Dielectric Withstanding Voltage (between terminals)	No abnormality												
13	Solderability	More than 95% of terminal electrode shall be covered with fresh solder.	<p>【Eutectic】 Used solder shall be [JIS Z 3282 H60A or H63A]. Test sample shall be completely submerged in molten solder of <math>230 \pm 5^\circ\text{C}</math> for <math>4 \pm 1</math> seconds.</p> <p>【Pb free】 Used solder shall be [Sn/3.0Ag/0.5Cu]. Test sample shall be completely submerged in molten solder of <math>245 \pm 3^\circ\text{C}</math> for <math>4 \pm 1</math> seconds.</p>										

No.	Item	Specified Value	Remarks																
14	Thermal Shock	Appearance	No abnormality	<p>Conforming to EIA RS-198-D (1991).            Test sample shall be soldered to test board shown in Fig.2.            Heat treatment specified in No.3 of the specification shall be conducted prior to test.            Test sample shall be kept for specified time at each of temperature in steps 1 to 4 shown below in sequence.</p> <table border="1" data-bbox="890 542 1423 801"> <thead> <tr> <th>Step</th> <th>Temperature (°C)</th> <th>Time (min)</th> </tr> </thead> <tbody> <tr> <td>1</td> <td>Lowest Operating temperature</td> <td>30±3</td> </tr> <tr> <td>2</td> <td>Normal temperature</td> <td>2~3</td> </tr> <tr> <td>3</td> <td>Highest operating temperature</td> <td>30±3</td> </tr> <tr> <td>4</td> <td>Normal temperature</td> <td>2~3</td> </tr> </tbody> </table> <p>Temperature cycle shall be repeated five times in this method, and measurement shall be conducted after test sample is kept for 24±2 hours.</p>	Step	Temperature (°C)	Time (min)	1	Lowest Operating temperature	30±3	2	Normal temperature	2~3	3	Highest operating temperature	30±3	4	Normal temperature	2~3
		Step	Temperature (°C)		Time (min)														
		1	Lowest Operating temperature		30±3														
		2	Normal temperature		2~3														
		3	Highest operating temperature		30±3														
4	Normal temperature	2~3																	
Capacitance Change	Within ±15.0%																		
Dissipation Factor	3.5% max																		
Insulation Resistance	Initial value shall be satisfied.																		
Dielectric Withstanding Voltage (between terminals)	No abnormality																		
15	Humidity (Steady State)	Appearance	No abnormality	<p>Conforming to EIA RS-198-D (1991).            Test sample shall be at 40±2°C with relative humidity of 90 to 95% for 500 +24/-0 hours.            Heat treatment specified in No.3 of the specification shall be conducted prior to test.            Measurement shall be conducted after test sample is kept for 24±2 hours.</p>															
		Capacitance Change	Within ±15.0%																
		Dissipation Factor	7.0% max																
		Insulation Resistance	25MΩ · μF min																
16	High Temperature Loading	Appearance	No abnormality	<p>Conforming to EIA RS-198-D (1991).            Test sample shall be put in thermostatic oven with maximum temperature and 200% of DC rated voltage shall be continuously applied for 1000 +48/-0 hours.            Charging and discharging current shall be 50mA or less.            Voltage treatment specified in No.4 of the specification shall be conducted prior to test.            Measurement shall be conducted after test sample is kept for 24±2 hours.</p>															
		Capacitance Change	Within ±15.0%																
		Dissipation Factor	7.0% max																
		Insulation Resistance	50MΩ · μF min																

No.	Item		Specified Value	Remarks
17	Humidity Loading	Appearance	No abnormality	<p>Conforming to EIA RS-198-D (1991).  Test sample shall be put in thermostatic oven with <math>40 \pm 2^\circ\text{C}</math> and relative humidity 90 to 95% and DC rated voltage shall be continuously applied for <math>500 + 24/-0</math> hours.  Charging and discharging current shall be 50mA or less.  Voltage treatment specified in No.4 of the specification shall be conducted prior to test.  Measurement shall be conducted after test sample is kept for <math>24 \pm 2</math> hours.</p>
		Capacitance Change	Within $\pm 15.0\%$	
		Dissipation Factor	7.0% max	
		Insulation Resistance	$10\text{M}\Omega \cdot \mu\text{F min}$	
18	Bending Strength	Appearance	No abnormality	<p>Test sample shall be soldered to test board as shown in Fig.3.  Soldering shall be conducted with care of avoiding an abnormality such as heat shock.  Deflection test is such that force to cause deflection as much as 1.0mm is applied for 10 seconds in method shown in Fig.4.  Measurement shall be conducted with deflection of 1.0mm.</p>
		Capacitance Change	Within $\pm 10\%$	

Part Numbering System

Class II :  $\frac{H}{①}$  MK  $\frac{325}{②}$   $\frac{\quad}{③}$   $\frac{B7}{④}$   $\frac{225}{\text{Capacitance}}$   $\frac{K}{⑤}$   $\frac{N}{⑥}$   $\frac{-T}{⑦}$

① Rated voltage

Code	Voltage
H	100V DC

② Size (mm)

Code	L×W
325	3.2×2.5

③ Control Code

※Per Fig.1

④ Temperature characteristics

Code	Temperature characteristic
B7(X7R)	±15%

Reference temperature 25°C

⑤ Tolerance

Code	Tolerance
K	±10%
M	±20%

⑥ Thickness

Code	Thickness rank [mm]
N	1.90

⑦ Packaging

Code	Packaging
-T	Taping

Fig.1 Shape and Dimensions

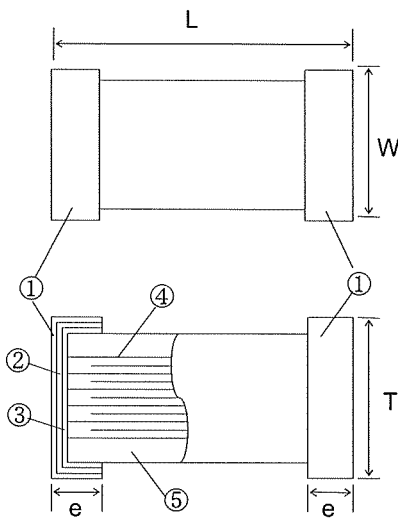

No.	Name	Material
①	Terminal Electrodes (Surface)	Sn Plating
②	Terminal Electrodes	Ni Plating
		Cu Plating
③	External Electrodes	Ni
④	Internal Electrodes	Ni
⑤	Dielectric	Barium titanate

Type	L		W		T		e
	Control Code	Dimensions	Control Code	Dimensions	Control Code	Dimensions	
325	Space	3.2±0.3	Space	2.5±0.2	Space	1.9±0.2	0.6±0.3

[Unit: mm]



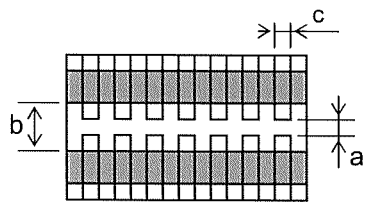

Fig.2 Board / Test Jig of Adhesive force of Terminal Electrodes, Vibration and Thermal Shock



Size(L×W)	a	b	c
3.2×2.5	2.2	5.0	2.9

[Unit: mm]

- Material: Glass epoxy board [JIS C 6484]  
 Copper foil (thickness: 0.035mm)  
 Solder resist

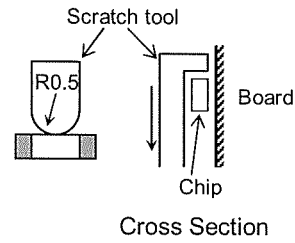

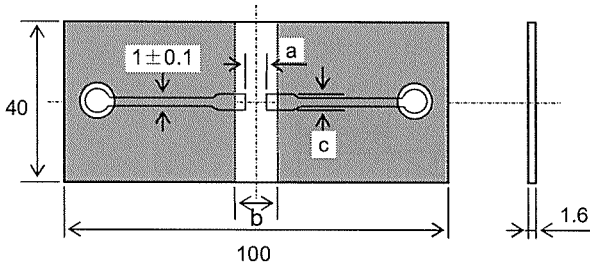

Remarks: Uniform soldering shall be conducted with solder (H60A or H63A in JIS Z 3282) by using an iron or soldering oven.  
 Soldering shall be conducted with care of avoiding an abnormality such as heat shock.

Fig.3 Test Board



Material: Glass epoxy board [JIS C 6484]

-  Copper foil (thickness: 0.035mm)  
 Solder resist

Size(L×W)	a	b	c
3.2×2.5	2.2	5.0	2.9

[Unit: mm]

Fig.4

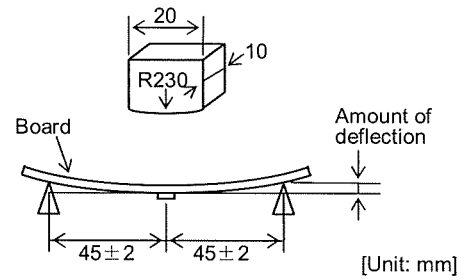

Apply pressure at the rate of 0.5mm/sec. until amount of deflection reaches to 1.0mm.

# Tape Packaging 325 Type

◎In case of taping packaging, plastic tapes shall be used.

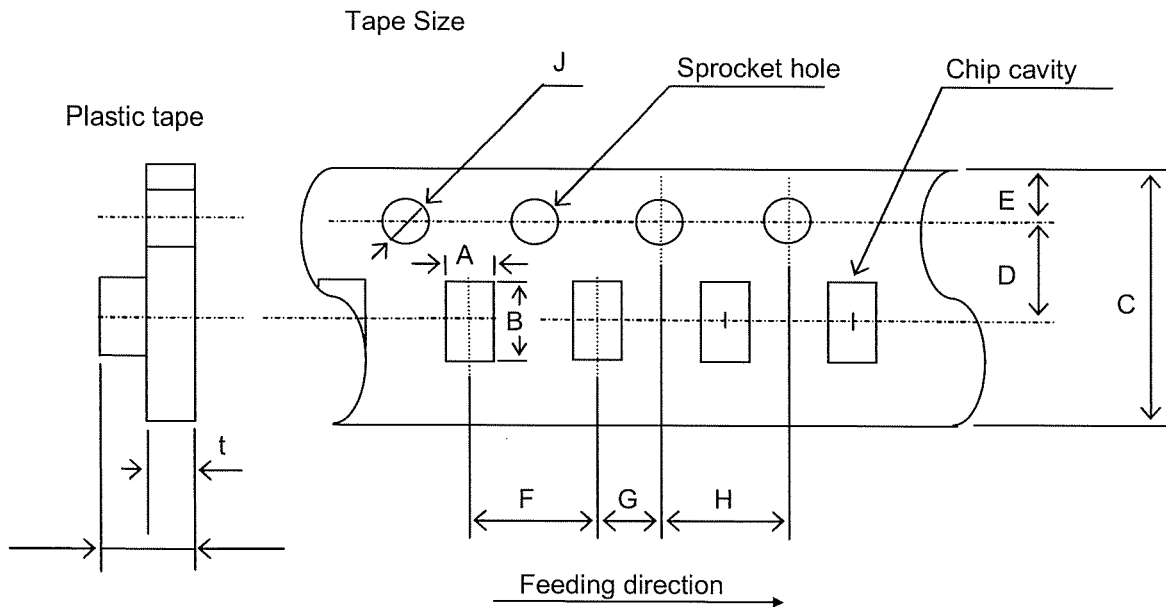

### Dimensions

Type	A※	B※
325	$2.8 \pm 0.2$	$3.6 \pm 0.2$

[Unit: mm]

### Dimensions

C	D	E	F	G	H	J	K	t※
$8.0 \pm 0.3$	$3.5 \pm 0.05$	$1.75 \pm 0.1$	$4.0 \pm 0.1$	$2.0 \pm 0.05$	$4.0 \pm 0.1$	$\phi 1.5^{+0.1}_{-0}$	3.4max.	0.6max.

※A, B, t : Sufficient clearance.

[Unit : mm]

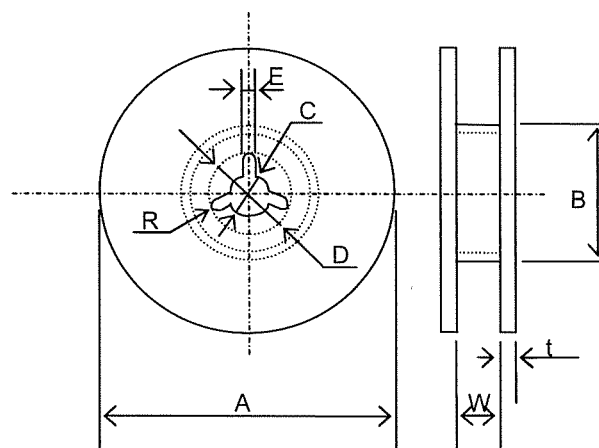

### Dimensions of Reel

A	B	C	D	E	W	t	R
$\phi 178 \pm 2.0$	$\phi 50$ min	$\phi 13.0 \pm 0.2$	$\phi 21.0 \pm 0.8$	$2.0 \pm 0.5$	$10.0 \pm 1.5$	2.5max.	1.0

[Unit: mm]

## Tape Packaging

1. Taping shall be right-sided wound. When the end is pulled out, sprocket hole will be at the right-hand side.

2. For packaging chips by taping, blank spaces are provided on taping as shown in the figure.

- Leader part 400mm min.
- Leader part (Blank part) 100mm min.
- Trailer (Blank part) 160mm min.

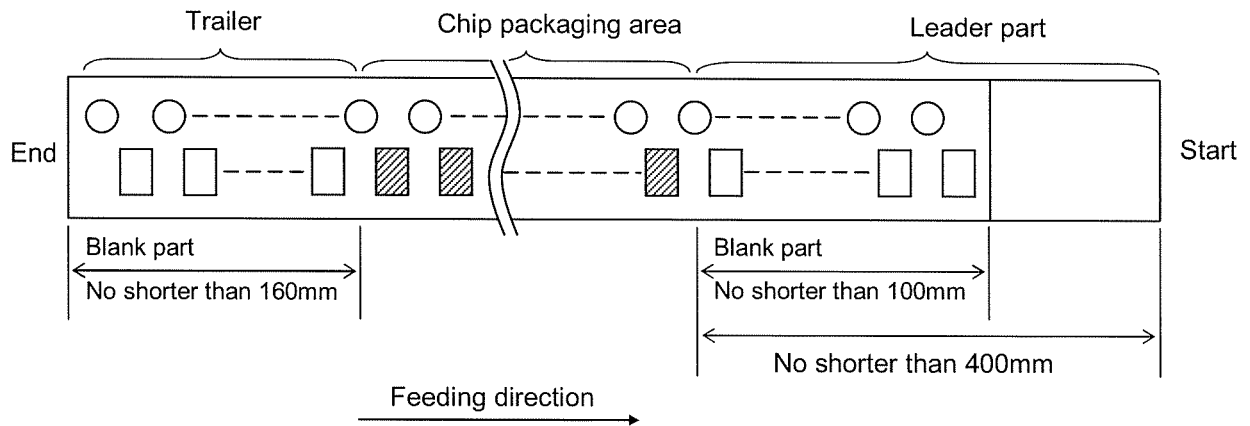

3. Seal tape of plastic taping shall not be crossed over sprocket holes.

4. Plastic tape shall not be seamed.

5. Tensile strength of the tape is 5N (0.51kgf) or over.

6. Number of chips missed from tape reel shall be 1 piece maximum per reel.

7. Standard number of chips contained in a reel shall be 2,000 pieces.

8. Label indicating part No., quantity and control No. shall be attached to the outside of reel.

9. Peeling strength of seal tape shall be 0.1~0.7N (10.2~71.4gf) when seal tape is peeled from carrier tape at an angle of  $0^{\circ} \sim 20^{\circ}$ .

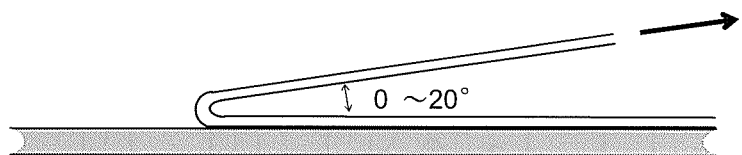

# Tape Packaging 325 Type

[Packaging Mode]

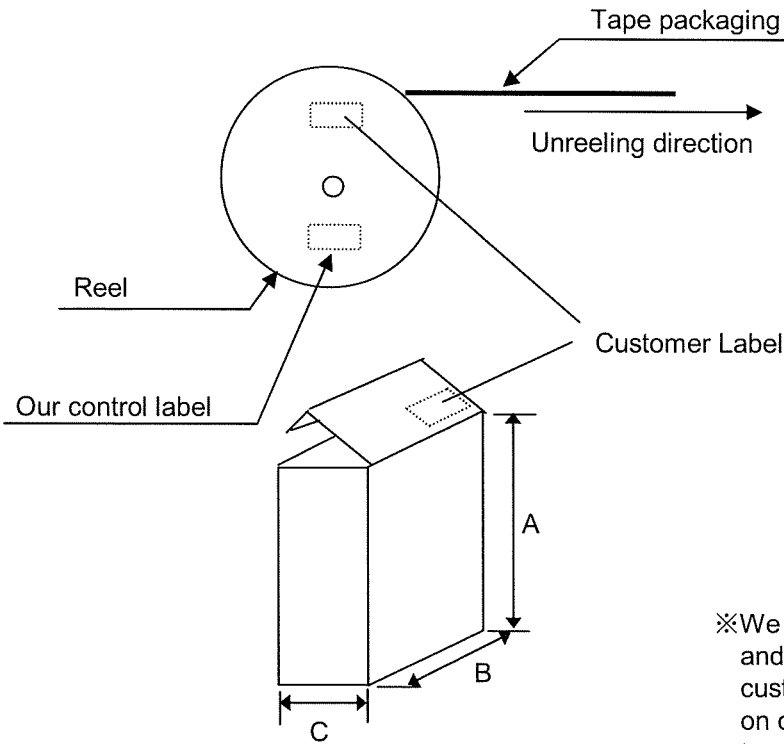

Customer Label contents

1. Manufacture Name
2. Customer Parts No.
3. Our parts no.
4. Quantity
5. Control No.  
(Shipping lot number) ※
6. Manufacturing site  
MADE IN ○○○

※We control our products by control number, and shipping lot numbering is not marked on customer label. Shipping lot number is marked on our control label. Shipping lot number is traceable from our control number marked on customer label

Code	A	B	C	reel
Size	190	185	70	5reel max
			140	10reel max

Material : Paper

[Unit : mm]

(The size is only for reference.)

Packaging unit : Maximum 5reel or 10reels in a box.

• To attach labels means that all products are passed.

## Composition of the shipping lot number

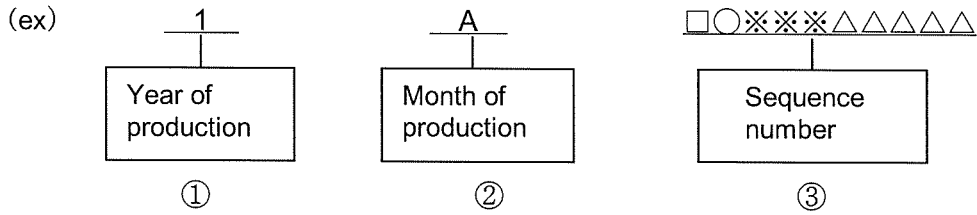

- ① Year of production (The last numeral of the Christian era. 2011<sup>year</sup> → 1)
- ② Month of production (It is due to the table below.)
- ③ Sequence number is alphanumeric including space.

Month	1	2	3	4	5	6	7	8	9	10	11	12
Code	A	B	C	D	E	F	G	H	J	K	L	M

## Recommended Soldering Profiles for Lead-free Solder Paste

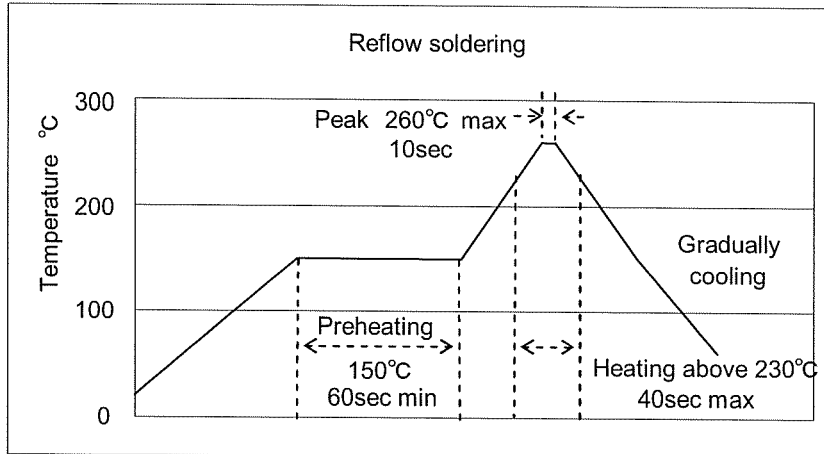

※Ceramic chip components should be preheated to within **100 to 130°C** from the soldering temperature.

※Assured to be reflow soldering for **2 times**.

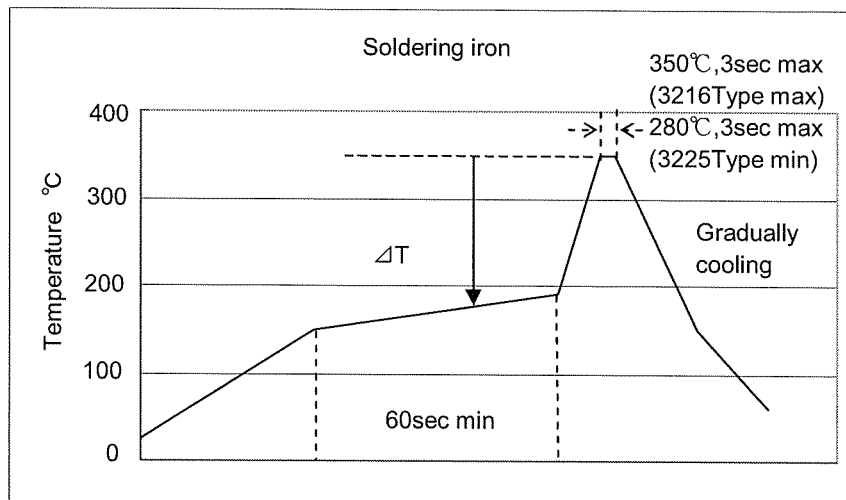

※  $\Delta T \leq 150^\circ\text{C}$  (3216 Type max),  $\Delta T \leq 130^\circ\text{C}$  (3225 Type min)

※Preheating control: Boards and components should be preheated sufficiently with temperature over 150°C, and soldering should be conducted by soldering iron while temperature of boards and components keep sufficient temperature.

※The soldering iron should not directly touch the components.

※Assured to be soldering iron for **1 time**.

※It is recommended to use 20W soldering iron and the tip is 1  $\phi$  or less.

Temperature in usage of Pb-free solder (Sn-3Ag-0.5Cu)

Case size	Soldering iron tip temp.	Preheating temp.
3216 type max.	$\leq 350^\circ\text{C}$	$\geq 150^\circ\text{C}$
3225 type min.	$\leq 280^\circ\text{C}$	$\geq 150^\circ\text{C}$

Note: The above profiles are the maximum allowable soldering condition, therefore these profiles are not always recommended.

Operating conditions for guarantee of this product are as shown in the specification.

Please note that Taiyo Yuden Co., Ltd. shall not be responsible for a failure and/or abnormality which are caused by use under the conditions other than aforesaid operating conditions.

- All electronic components listed in this specification are developed, designed and intended for use in general electronics equipment.(for AV, office automation, household, office supply, information service, telecommunications, (such as mobile phone or PC) etc.). Before incorporating the components or devices into any equipment in the field such as transportation, (automotive control, train control, ship control), transportation signal, disaster prevention, medical, public information network(telephone exchange, base station) etc. which may have direct influence to harm or injure a human body, please contact Taiyo Yuden Co., Ltd. for more detail in advance.

Do not incorporate the products into any equipment in fields such as aerospace, aviation, nuclear control, submarine system, military, etc. where higher safety and reliability are especially required. In addition, even electronic components or functional modules that are used for the general electronic equipment, if the equipment or the electric circuit require high safety or reliability function or performances, a sufficient reliability evaluation check for safety shall be performed before commercial shipment and moreover, due consideration to install a protective circuit is strongly recommended at customer's design stage.

- Please conduct validation and verification of products in actual condition of mounting and operating environment before commercial shipment of the equipment.
- The contents of this specification are applicable to the products which are purchased from our sales offices or distributors (so called TAIYO YUDEN's official sales channel ).  
It is only applicable to the products purchased from any of TAIYO YUDEN's official sales channel.
- Please note that Taiyo Yuden Co., Ltd. shall have no responsibility for any controversies or disputes that may occur in connection with a third party's intellectual property rights and other related rights arising from your usage of products in this specification. Taiyo Yuden Co., Ltd. grants no license for such rights.

- Caution for export

Certain items in this specification may require specific procedures for export according to Foreign Exchange and Foreign Trade Control Law of Japan, U.S. Export Administration Regulations, and other applicable regulations. Should you have any question or inquiry on this matter, please contact our sales staff.