

THIS DRAWING IS UNPUBLISHED. RELEASED FOR PUBLICATION
 © COPYRIGHT - By - ALL RIGHTS RESERVED.

LOC		DIST		REVISIONS			
P	LTR	DESCRIPTION	DATE	DWN	APVD		
	C	ECO-13-005473	4-17-13	CT	DE		

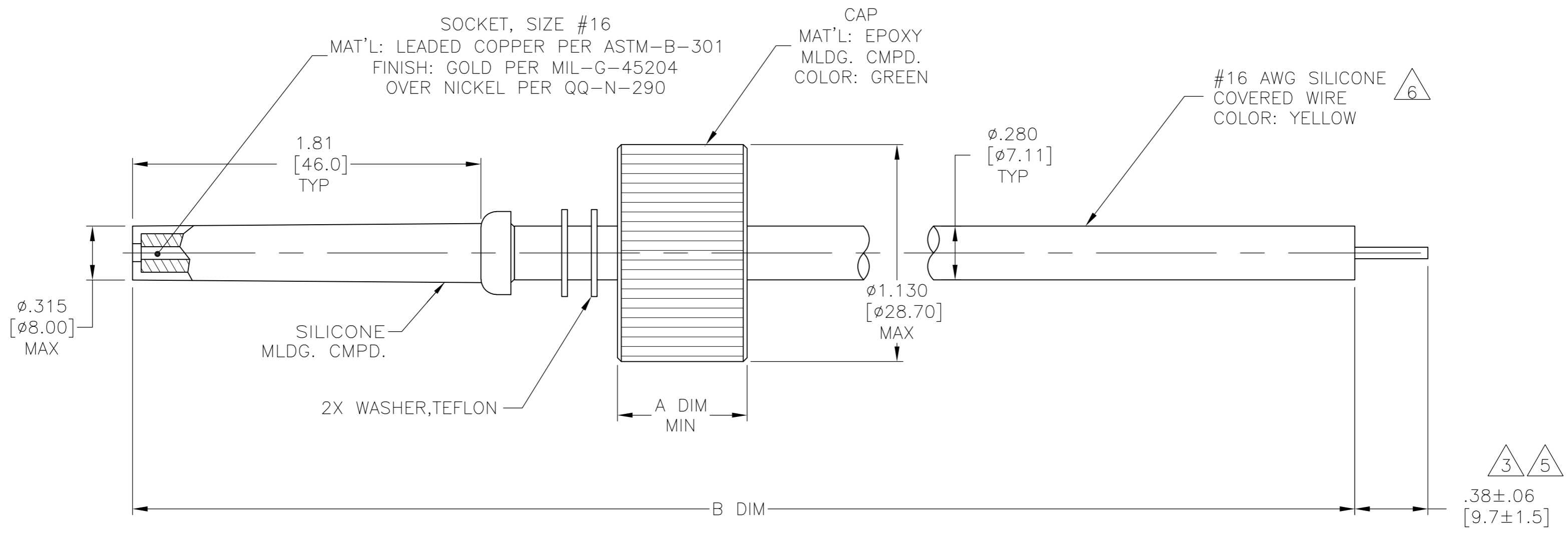

1. MARKED PER MIL-STD-130.
 2. LEADS WILL MATE WITH AMP LGH-3 RECEPTACLE WITH 1.81 [46.0] BARREL DEPTH.
 3. PIGTAIL IS SOLDER DIPPED.
 4. OPERATING VOLTAGE: 40 KVDC AT 0 TO 70,000 FEET, -55° C TO 125° C.
5. INSULATION CUT, BUT NOT REMOVED
6. YELLOW WIRE DOES NOT HAVE A SOLID YELLOW INSULATION BUT IS A WHITE WIRE WITH A YELLOW STRIPE.

REMARKS	DIM B	DIM A MIN	PART NUMBER
5	60.00±1.00 [1524.0±25.4]	.67 [17.0]	5-868353-2
3	60.00±1.00 [1524.0±25.4]	.67 [17.0]	868353-2
3	18.00±.12 [457.2±3.0]	.55 [13.8]	868353-1

THIS DRAWING IS A CONTROLLED DOCUMENT.		DWN C.C.THOMAS 12-15-97		
		CHK D.EABY 12/15/97		
DIMENSIONS: INCHES [mm]		TOLERANCES UNLESS OTHERWISE SPECIFIED:		NAME LEAD ASSY,SGL END,LGH-3 WIRE COLOR: WHITE AND YELLOW STRIPED
		0 PLC ± - 1 PLC ± - 2 PLC ± .02 [0.5] 3 PLC ± - 4 PLC ± - ANGLES ± -		
MATERIAL SEE CALLOUTS		FINISH SEE CALLOUTS		SIZE A2
		WEIGHT -		CAGE CODE 00779
		CUSTOMER DRAWING		DRAWING NO 868353
		SCALE 2:1		SHEET 1 of 1
				REV C

868353