

Low Voltage Dual SP3T Analog Switch 3:1 Mux/DeMux Bus Switch

Features

- CMOS Technology for Bus and Analog Applications
- Low On-Resistance: 0.5Ω (typ) on channels 0 and 1
1.65Ω (typ) on channel 2
- Wide V_{CC} Range: 1.65V to 5.5V
- Rail-to-Rail Signal Range
- Control Input Overvoltage Tolerance: 5.5V min.
- High Off Isolation: -42dB
- Crosstalk Rejection Reduces Signal Distortion: -72dB
- Break-Before-Make Switching
- Low THD (0.02% typ @ V_{CC} = 2.7V for channels 0 and 1)
- Extended Industrial Temperature Range: -40°C to 85°C
- Packaging: (Pb-free & Green)
- 12-ball CSP

Applications

- Cell Phones
- PDAs
- MP3 players
- Portable Instrumentation
- Computer Peripherals
- Speaker Headset Switching
- Power Routing
- Relay Replacement
- Audio and Video Signal Routing
- PCMCIA Cards
- Modems

Pin Description

Pin #	Name	Description
A3, C3	_y A	Common Output/Data Port
A1, A2, A4	₁ B _x	Data Port
C1, C2, C4	₂ B _x	Data Port
B2, B3	S ₀ , S ₁	Logic Input Control
B1	GND	Ground
B4	V _{CC}	Positive Power Supply

Note:

1. x = 0, 1, or 2
2. y = 1 or 2

Description

Pericom Semiconductor's PI5A4213 is a dual high-bandwidth, fast single-pole triple throw (SP3T) CMOS switch. It can be used as an analog switch or as a low-delay bus switch. The PI5A4213 is specified over a wide operating power supply voltage, 1.65V to 5.5V.

Break-before-make switching prevents both switches being enabled simultaneously. This eliminates signal disruption during switching.

The control input, S, tolerates input drive signals up to 6.0V, independent of supply voltage.

Pin Configuration / Block Diagram (top view)

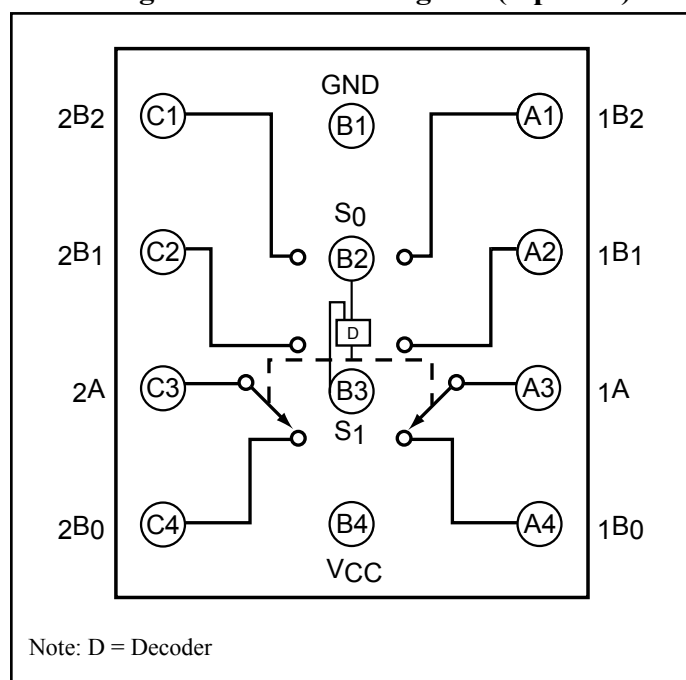

Logic Function Table

Logic Input		Function
S ₁	S ₀	
0	0	_x B ₀ Connected to _x A
0	1	_x B ₁ Connected to _x A
1	0	_x B ₂ Connected to _x A
1	1	No Connection

Note:

1. x = 1 or 2

Absolute Maximum Ratings⁽¹⁾

Supply Voltage V_{CC}	-0.5V to +7V
DC Switch Voltage (V_S) ⁽²⁾	-0.5V to $V_{CC} + 0.5V$
DC Input Voltage (V_{IN}) ⁽²⁾	-0.5V to +7.0V
DC Output Current (V_{OUT})	128mA
DC V_{CC} or Ground Current (I_{CC}/I_{GND})	$\pm 100mA$
Storage Temperature Range (T_{STG})	-65°C to +150°C
Junction Temperature under Bias (T_J)	150°C
Junction Lead Temperature (T_L)	
(Soldering, 10 seconds)	260°C
Power Dissipation (P_D) @ +85°C	180mW

Recommended Operating Conditions⁽³⁾

Supply Voltage Operating (V_{CC})	1.65V to 5.5V
Control Input Voltage (V_{IN})	0V to V_{CC}
Switch Input Voltage (V_{IN})	0V to V_{CC}
Output Voltage (V_{OUT})	0V to V_{CC}
Operating Temperature (T_A)	-40°C to +85°C
Input Rise and Fall Time (t_r, t_f)	
Control Input $V_{CC} = 2.3V - 3.6V$	0ns/V to 10ns/V
Control Input $V_{CC} = 4.5V - 5.5V$	0ns/V to 5ns/V
Thermal Resistance (θ_{JA})	350°C/W

Notes:

1. Absolute Maximum Ratings may cause permanent damage to the device. This is a stress only rating and operation of the device at these or any other conditions beyond those indicated in the operational sections of this specification is not implied.
2. The input and output negative voltage ratings may be exceeded if the input and output diode current ratings are observed.
3. Control input must be held HIGH or LOW; it must not float.

DC Electrical Characteristics +3V Supply

($V_{CC} = 2.7V$ to $3.3V$, $T_A = T_{MIN}$ to T_{MAX} , unless otherwise noted. Typical values are at $3V$ and $+25^{\circ}C$.)

Parameter	Symbol	Test Conditions	Min.	Typ.	Max.	Units
Analog Switch						
Analog Signal Range	V_A, V_B		0		V_{CC}	V
On-Resistance	R_{ON}	$V_{CC} = 2.7V, I_A = 100mA, V_B = 0$ to V_{CC}	ch. 2	1.6	2.0	Ω
			ch.0 + 1	0.5		
On-Resistance Match Between Channels	ΔR_{ON}	$V_{CC} = 2.7V, I_A = 100mA, V_B = 1.5V$			0.1	
On-Resistance Flatness	R_{ONF}	$V_{CC} = 2.7V, I_A = 100mA, V_B = 0$ to V_{CC}			0.5	
Off Leakage Current	$I_{B(OFF)}$	$V_{CC} = 3.3V, V_B = 3V, 0.3V, V_A = 0.3V, 3V$	-80		80	nA
On Leakage Current	$I_{A(ON)}$	$V_{CC} = 3.3V, V_B = 3V, 0.3V, V_A = 0.3V, 3V$, or floating	-160		160	
Digital I/O						
Input Logic High	V_{IH}		1.8			V
Input Logic Low	V_{IL}				0.6	
S_X Input Leakage Current	I_{IN}	$V_{IN} = 0$ or V_{CC}	-1		1	μA
Power Supply						
Power-Supply Range	V_{CC}		1.65		5.5	V
Supply Current	I_{CC}	$V_{CC} = 5.5V, V_{IN} = 0$ or V_{CC}		100	1000	nA

Switch and AC Characteristics

Parameter	Symbol	Test Conditions	Min.	Typ.	Max.	Units
Turn-On Time	t_{ON}	$V_{CC} = 2.7V, V_B = 1.5V,$ $R_L = 50\Omega, C_L = 35pF, \text{ See Test Circuit Fig. 1 \& 2}$		13	15	ns
Turn-Off Time	t_{OFF}	$V_{CC} = 2.7V, V_B = 1.5V,$ $R_L = 50\Omega, C_L = 35pF, \text{ See Test Circuit Fig. 1 \& 2}$		10.0	12	
Break-Before-Make Delay	t_{BBM}	$V_{CC} = 2.7V, V_B = 1.5V,$ $R_L = 50\Omega, C_L = 35pF, \text{ See Test Circuit Fig. 3}$	2	15.0		
Charge Injection	Q	$V_{GEN} = 0V, C_L = 1nF, R_{GEN} = 0\Omega,$ <i>See Test Circuit Fig. 4</i>		35		pC
Off-Isolation	O_{IRR}	$C_L = 5pF, R_L = 50\Omega, f = 100kHz,$ $V_A = 1 V_{RMS}, \text{ See Test Circuit Fig. 5}$		-42		dB
Crosstalk	X_{TALK}	$C_L = 5pF, R_L = 50\Omega, f = 100kHz,$ $V_A = 1 V_{RMS}, \text{ See Test Circuit Fig. 6}$		-72		
3dB Bandwidth	f_{3dB}	<i>See Test Circuit Figure 9.</i>		30		MHz
Total Harmonic Distortion	THD for ch. 0 and ch. 1	$R_L = 32\Omega, V_{IN} = 3.5V, V_{CC} = 4.5V$ $f=20Hz \text{ to } 20kHz$		0.03		%
		$R_L = 32\Omega, V_{IN} = 2.0V, V_{CC} = 3.4V$ $f=20Hz \text{ to } 20kHz$		0.025		
		$R_L = 32\Omega, V_{IN} = 1.5V, V_{CC} = 2.7V$ $f=20Hz \text{ to } 20kHz$		0.02		
	THD for ch. 2	$R_L = 32\Omega, V_{IN} = 3.5V, V_{CC} = 4.5V$ $f=20Hz \text{ to } 20kHz$		0.30		
		$R_L = 32\Omega, V_{IN} = 2.0V, V_{CC} = 3.4V$ $f=20Hz \text{ to } 20kHz$		0.26		
		$R_L = 32\Omega, V_{IN} = 1.5V, V_{CC} = 2.7V$ $f=20Hz \text{ to } 20kHz$		0.26		

Capacitance

Parameter	Symbol	Test Conditions	Min.	Typ.	Max.	Units
Off Capacitance	$C_{A(OFF)}$	$f = 1 \text{ MHz}, \text{ See Test Circuit Figure 7}$		50		pF
Off Capacitance	$C_{B(OFF)}$	$f = 1 \text{ MHz}, \text{ See Test Circuit Figure 7}$		50		
On Capacitance	C_{ON}	$f = 1 \text{ MHz}, \text{ See Test Circuit Figure 8}$		200		

Test Circuits and Timing Diagrams

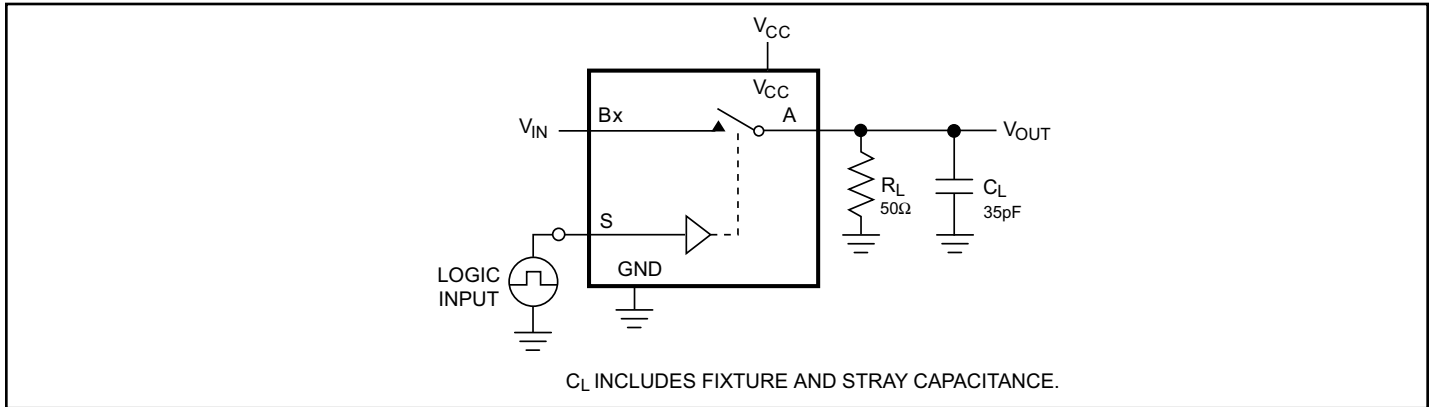

Figure 1. AC Test Circuit

Notes:

1. Unused Bx inputs must be grounded.

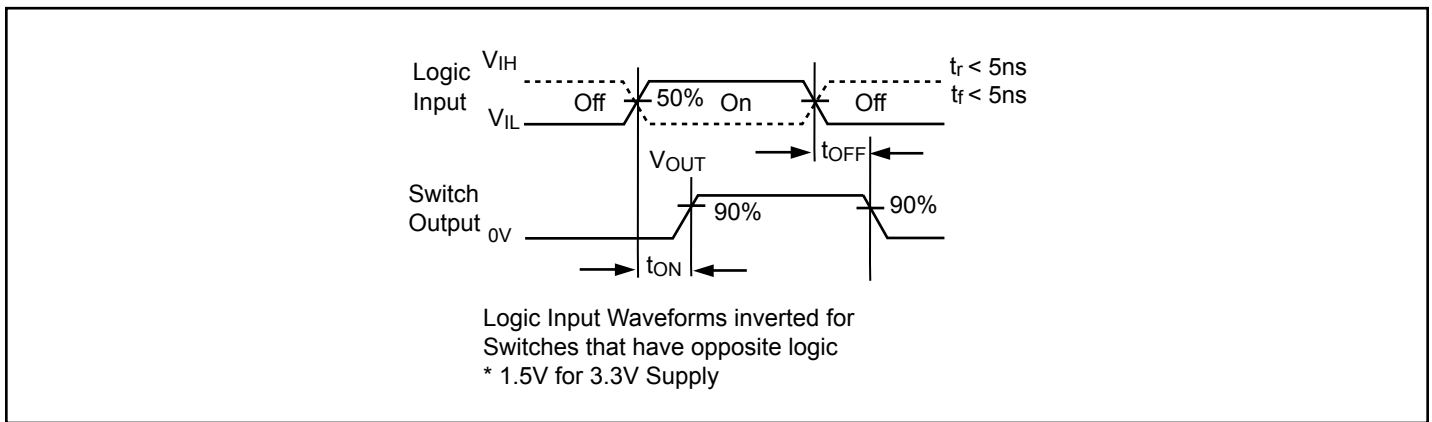

Figure 2. AC Waveforms

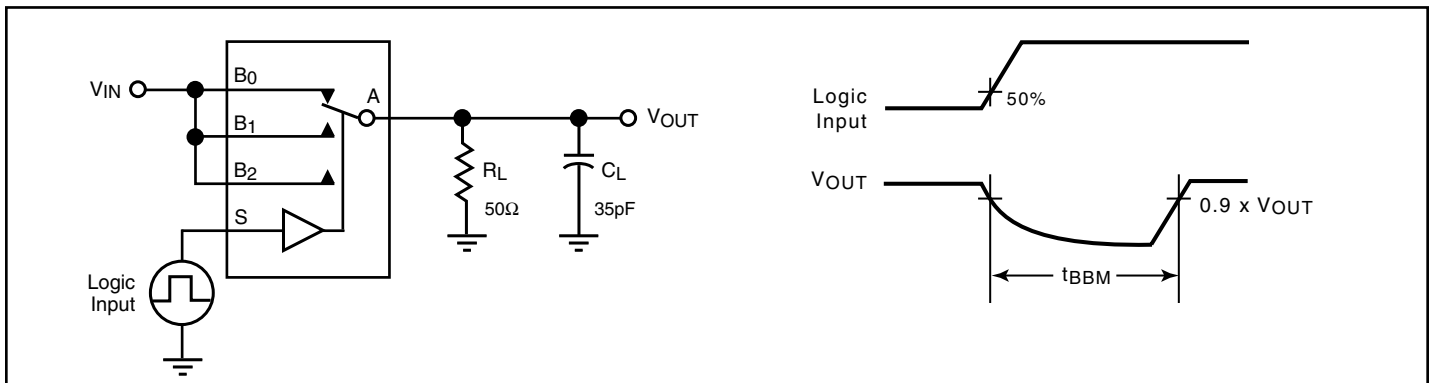

Figure 3. Break Before Make Interval Timing

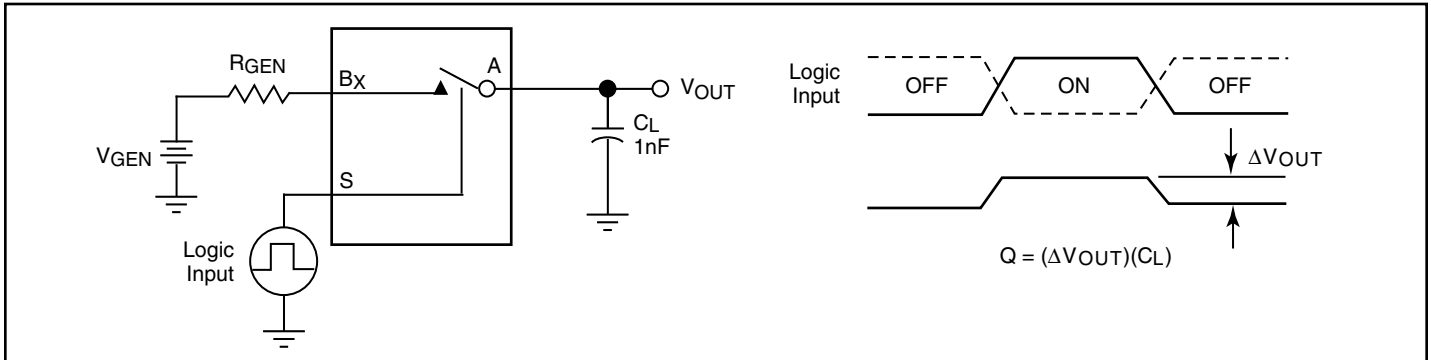

Figure 4. Charge Injection Test

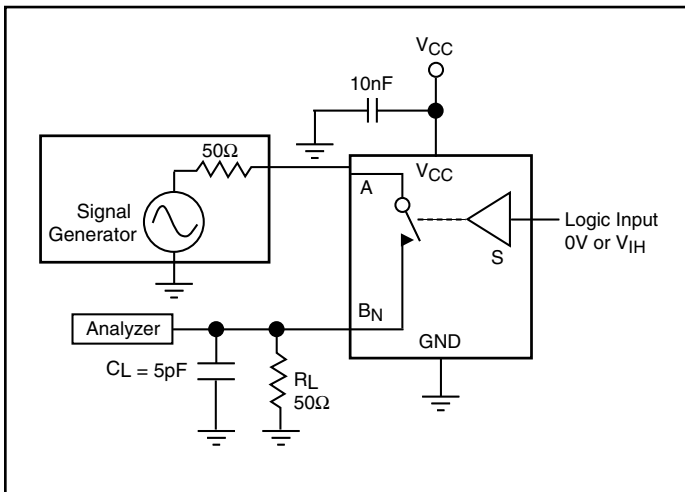

Figure 5. Off Isolation

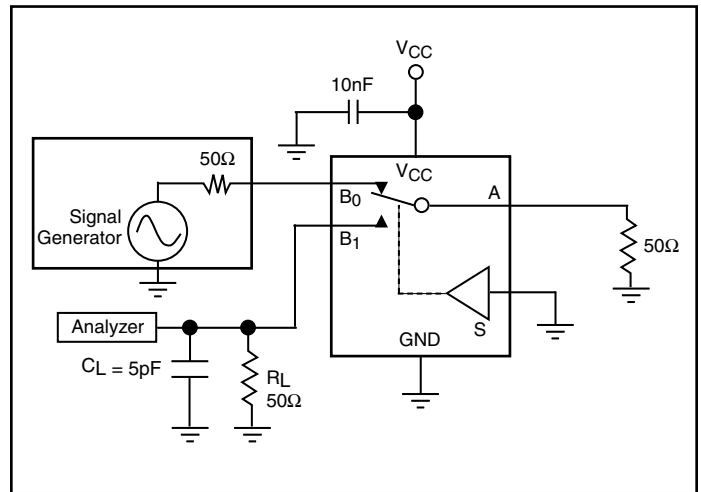

Figure 6. Crosstalk

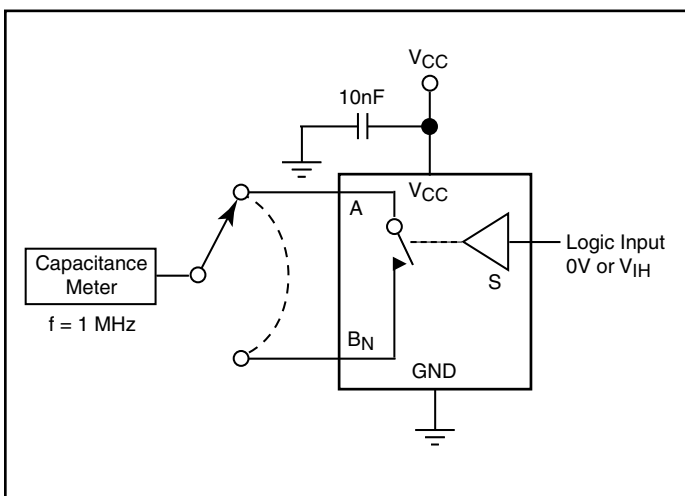

Figure 7. Channel Off Capacitance

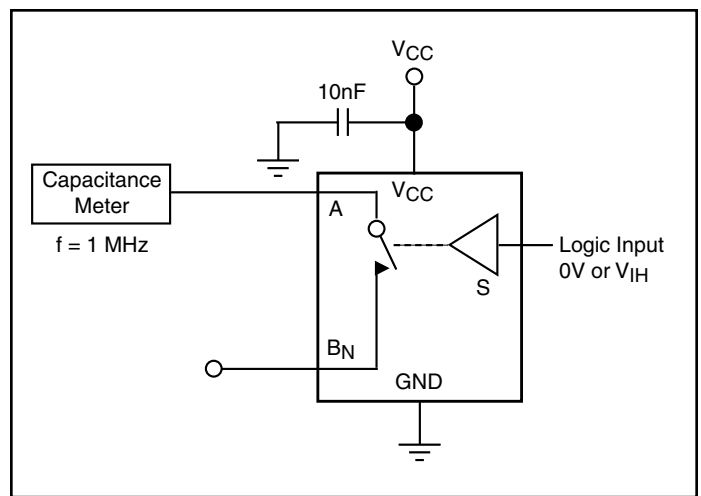

Figure 8. Channel On Capacitance

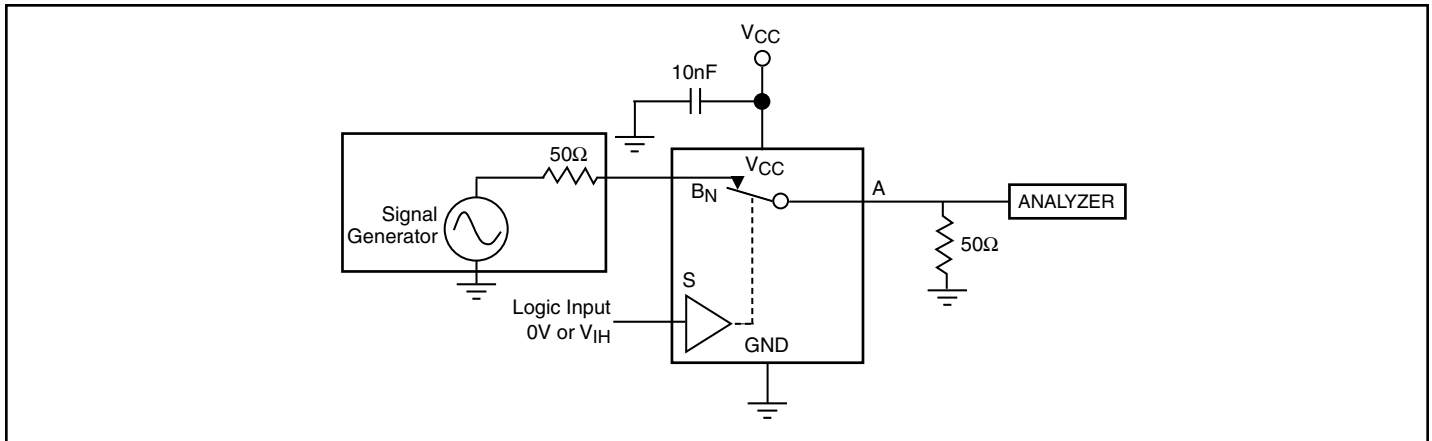
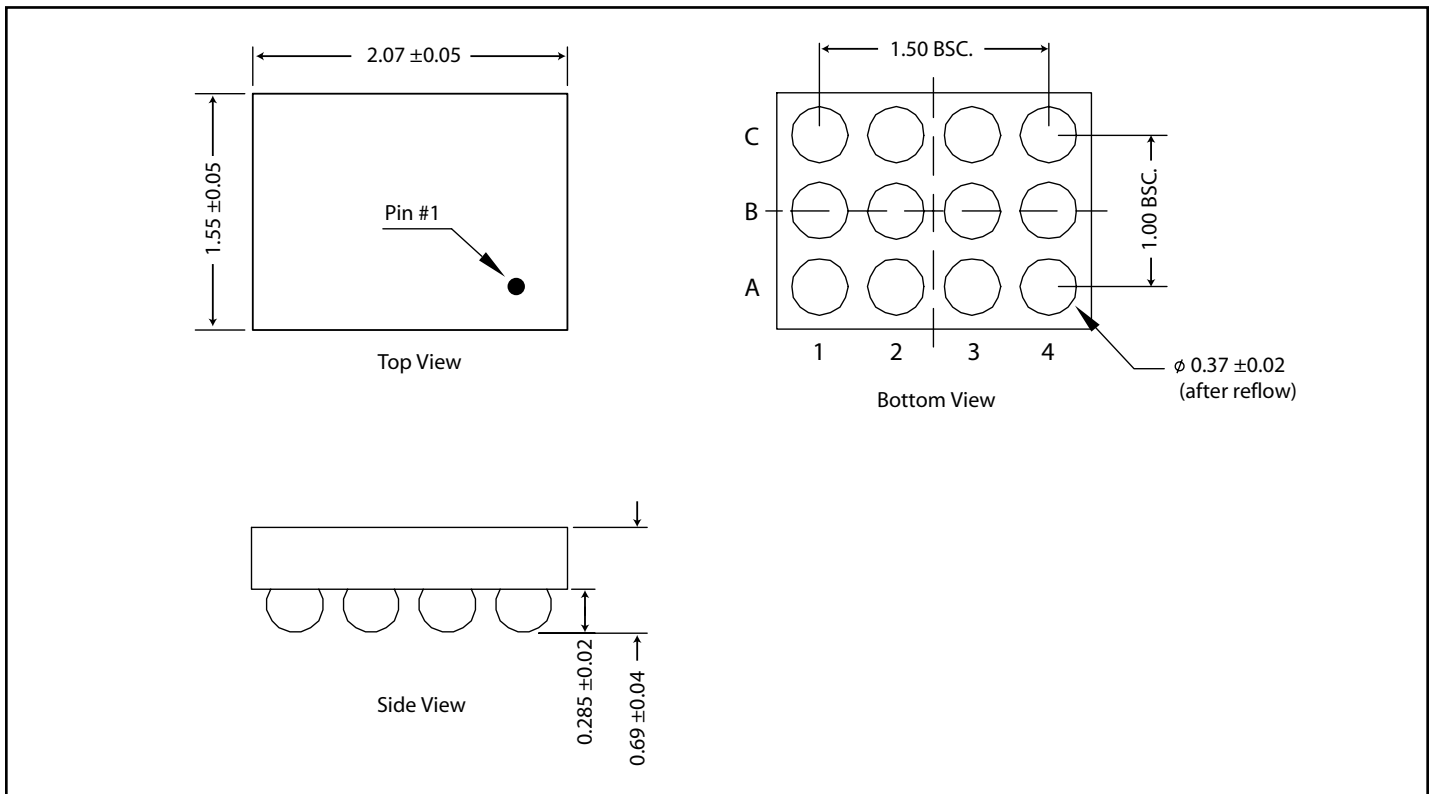

Figure 9. Bandwidth

Packaging Mechanical : 2x1.5 mm CSP



Ordering Information

Ordering Code	Packaging Code	Package Type
PI5A4213GAE	GA	Pb-free & Green, 12-ball CSP

Note:

- Thermal characteristics can be found on the company web site at www.pericom.com/packaging/
- X suffix = Tape & Reel
- E = Pb-free & Green