

DO NOT
SCALE FROM
THIS PRINT

No OF POSITIONS
(PER ROW)
-10, -20, -30, *-40

COMPRESSION
-2: DOUBLE

HEIGHT
-1.27

TAPE & REEL OPTION (SEE NOTE 7 & 8)
BLANK: TAPE & REEL
-FR: FULL REEL QTY TAPE & REEL

ROWS SPECIFICATION
-10: 10 ROWS

PLATING SPECIFICATION
-G: 10µm GOLD IN CONTACT AREA

(* = NOT TOOLED)

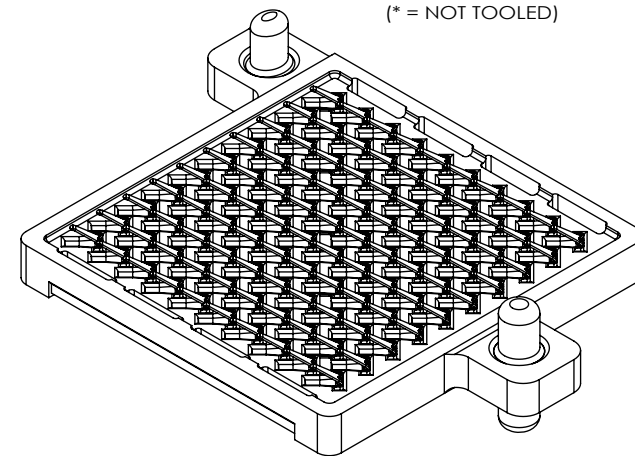
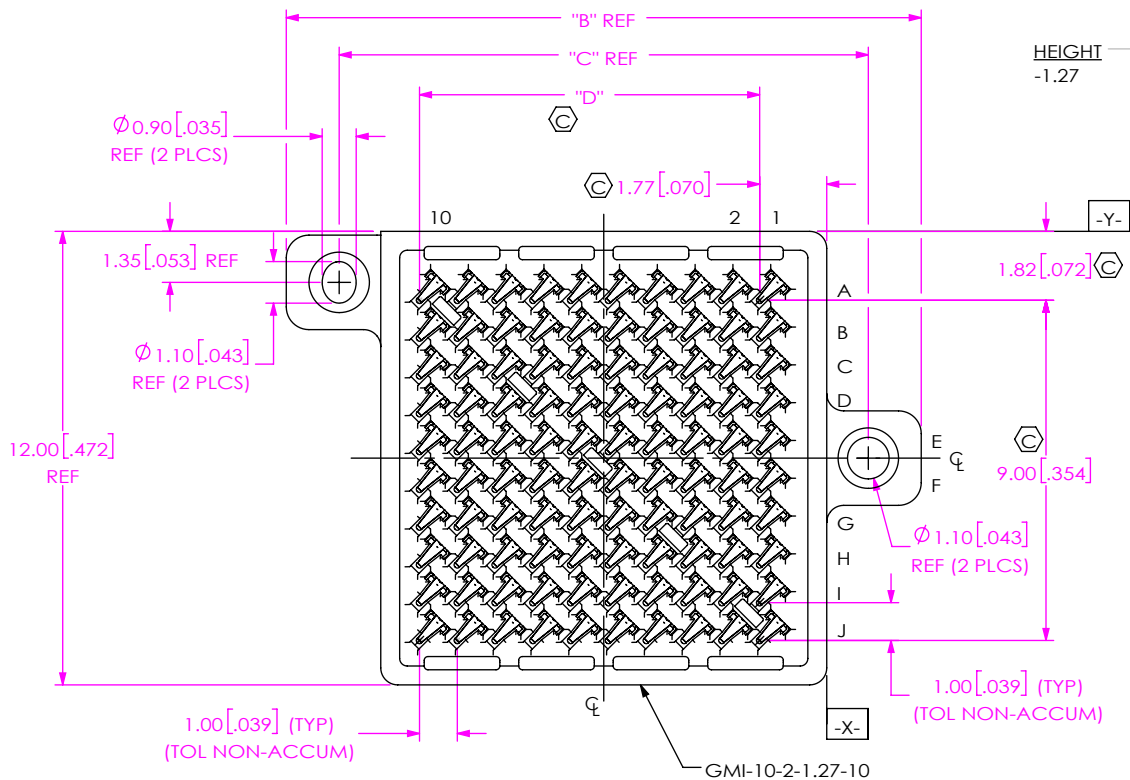

TABLE 3

No OF POS	
-10	0.05 [0.002]
-20	0.10 [0.004]
-30	0.15 [0.006]
-40	0.15 [0.006]

TABLE 2

No OF POS	"B"	"C"	"D"
-10	16.80 [0.661]	14.00 [0.551]	9.00 [0.354]
-20	26.80 [1.055]	24.00 [0.945]	19.00 [0.748]
-30	36.80 [1.449]	34.00 [1.339]	29.00 [1.142]
-40	46.80 [1.843]	44.00 [1.732]	39.00 [1.535]

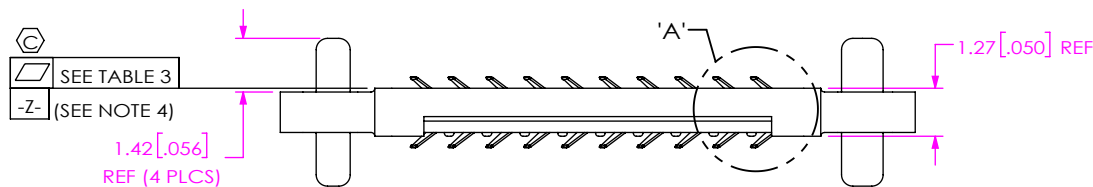

FIG 1
GMI-10-2-1.27-X-10 SHOWN

NOTES:

1. Ⓢ REPRESENTS A CRITICAL DIMENSION.
2. CONTACT POINTS ARE MEASURED IN UNCOMPRESSED STATE.
3. INSPECT ALL PINS IN THE FIRST & LAST COLUMN TO ALL POSITIONS.
4. SEE FIGURE 5, SHT 3 FOR DATUM TARGET LOCATIONS.
5. PARTS TO BE PACKAGED IN TAPE & REEL.
6. DELETED NOTE.
7. ORDERS WILL BE PACKAGED ACCORDING TO THE SAMTEC PACKAGING EFFICIENCY STANDARDS (SPES) FOUND ON WWW.SAMTEC.COM
8. ATTACH LABEL TO EACH REEL.

UNLESS OTHERWISE SPECIFIED,
DIMENSIONS ARE IN MILLIMETERS.
TOLERANCES ARE:
DECIMALS ANGLES
X.X: ±0.3 [0.1] 2°
X.XX: ±0.13 [0.05]
X.XXX: ±0.051 [0.020]

PROPRIETARY NOTE

THIS DOCUMENT CONTAINS CONFIDENTIAL AND PROPRIETARY INFORMATION AND ALL DESIGN, MANUFACTURING, REPRODUCTION, USE, PATENT RIGHTS AND SALES RIGHTS ARE EXPRESSLY RESERVED BY SAMTEC, INC. THIS DOCUMENT SHALL NOT BE DISCLOSED, IN WHOLE OR PART, TO ANY UNAUTHORIZED PERSON OR ENTITY NOR REPRODUCED, TRANSFERRED OR INCORPORATED IN ANY OTHER PROJECT IN ANY MANNER WITHOUT THE EXPRESS WRITTEN CONSENT OF SAMTEC, INC.

MATERIAL: DO NOT SCALE DRAWING
INSULATOR: LCP, COLOR: BLACK
CONTACT: COPPER ALLOY

SHEET SCALE: 5:1



520 PARK EAST BLVD, NEW ALBANY, IN 47150
PHONE: 812-944-6733 FAX: 812-948-5047
e-Mail: info@SAMTEC.com code 55322

DESCRIPTION: GMI ASSEMBLY

DWG. NO. GMI-XX-X-X.XX-X-XX-XX

BY: VICKY Z 02/07/2014 SHEET 1 OF 3

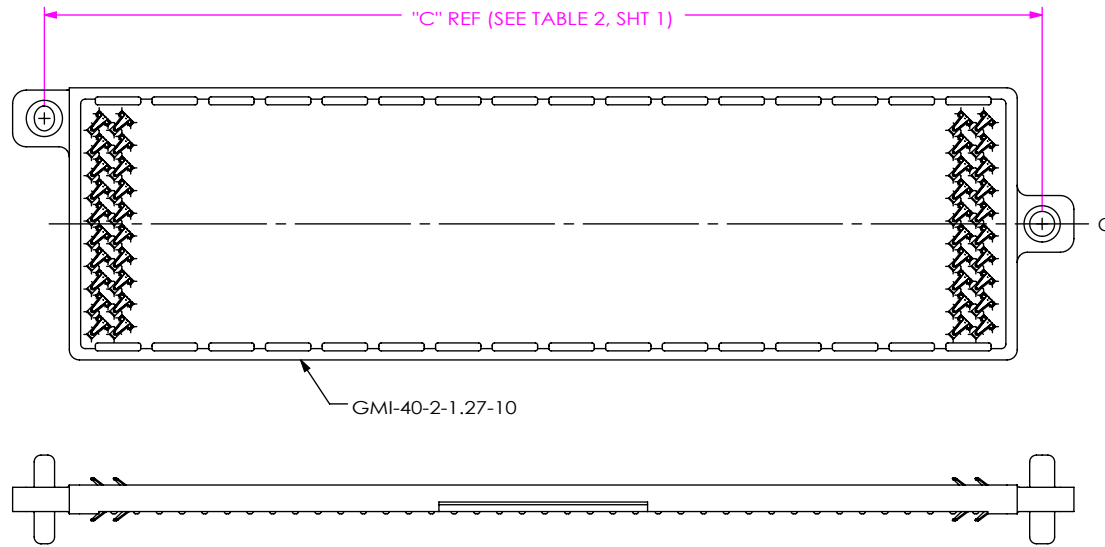
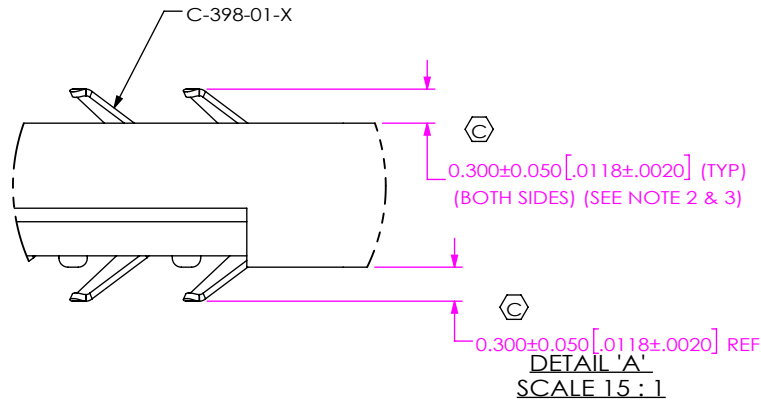

FIG 2
 GMI-40-2-1.27-X-10 SHOWN
 (CENTER FEATURES REMOVED FOR CLARITY)
 (DIFFERENT AS SHOWN, OTHERWISE SAME AS FIG 1)
 (NOT TOOLED)

PROPRIETARY NOTE
 THIS DOCUMENT CONTAINS CONFIDENTIAL AND PROPRIETARY INFORMATION AND ALL DESIGN, MANUFACTURING, REPRODUCTION, USE, PATENT RIGHTS AND SALES RIGHTS ARE EXPRESSLY RESERVED BY SAMTEC, INC. THIS DOCUMENT SHALL NOT BE DISCLOSED, IN WHOLE OR PART, TO ANY UNAUTHORIZED PERSON OR ENTITY NOR REPRODUCED, TRANSFERRED OR INCORPORATED IN ANY OTHER PROJECT IN ANY MANNER WITHOUT THE EXPRESS WRITTEN CONSENT OF SAMTEC, INC.

DO NOT SCALE DRAWING

SHEET SCALE: 30:1



520 PARK EAST BLVD, NEW ALBANY, IN 47150
 PHONE: 812-944-6733 FAX: 812-948-5047
 e-Mail info@SAMTEC.com code 55322

DESCRIPTION: GMI ASSEMBLY

DWG. NO. GMI-XX-X-X.XX-X-XX-XX

BY: VICKY Z 02/07/2014 SHEET 2 OF 3

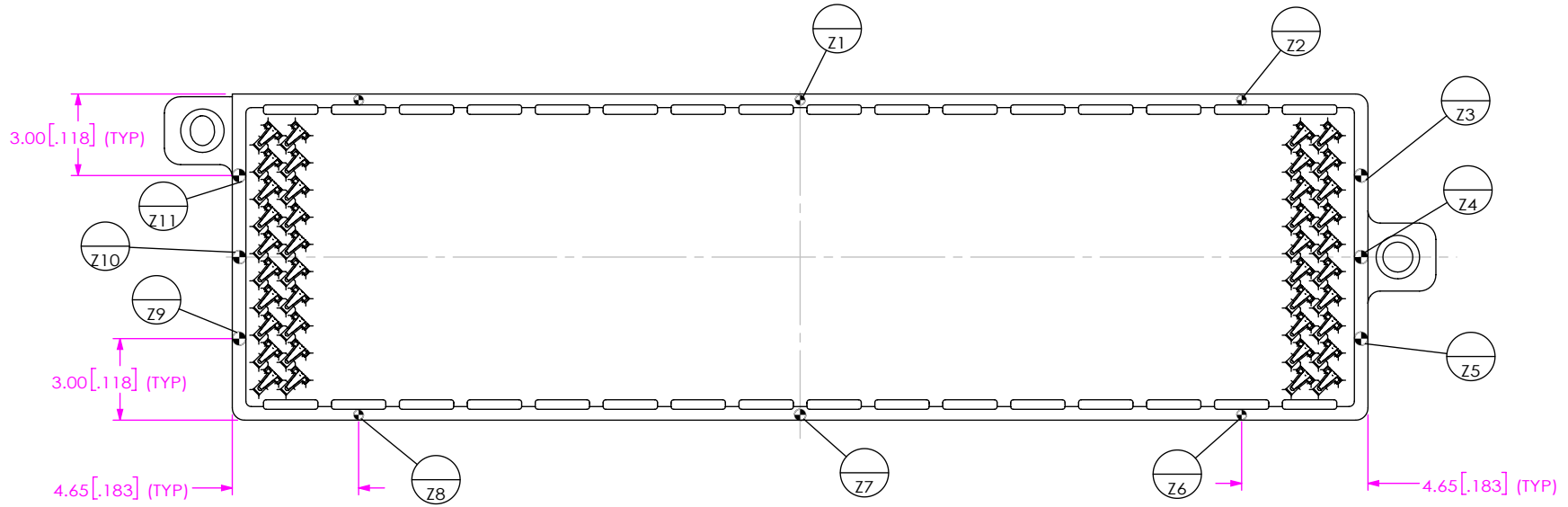

FIG 5
(Z-DATUM MEASUREMENT POINTS)
(APPLIES TO ALL POSITIONS)

PROPRIETARY NOTE
 * THIS DOCUMENT CONTAINS CONFIDENTIAL AND PROPRIETARY INFORMATION AND ALL DESIGN, MANUFACTURING, REPRODUCTION, USE, PATENT RIGHTS AND SALES RIGHTS ARE EXPRESSLY RESERVED BY SAMTEC, INC. THIS DOCUMENT SHALL NOT BE DISCLOSED, IN WHOLE OR PART, TO ANY UNAUTHORIZED PERSON OR ENTITY NOR REPRODUCED, TRANSFERRED OR INCORPORATED IN ANY OTHER PROJECT IN ANY MANNER WITHOUT THE EXPRESS WRITTEN CONSENT OF SAMTEC, INC.

DO NOT SCALE DRAWING

SHEET SCALE: 2:1



520 PARK EAST BLVD, NEW ALBANY, IN 47150
 PHONE: 812-944-6733 FAX: 812-948-5047
 e-Mail info@SAMTEC.com code 55322

DESCRIPTION: GMI ASSEMBLY

DWG. NO. GMI-XX-X-X.XX-X-XX-XX

BY: VICKY Z 02/07/2014 SHEET 3 OF 3