

PART NUMBER	REV	FIRST USED
1852120-1	A	122500-1
1852120-2	A	565435-5

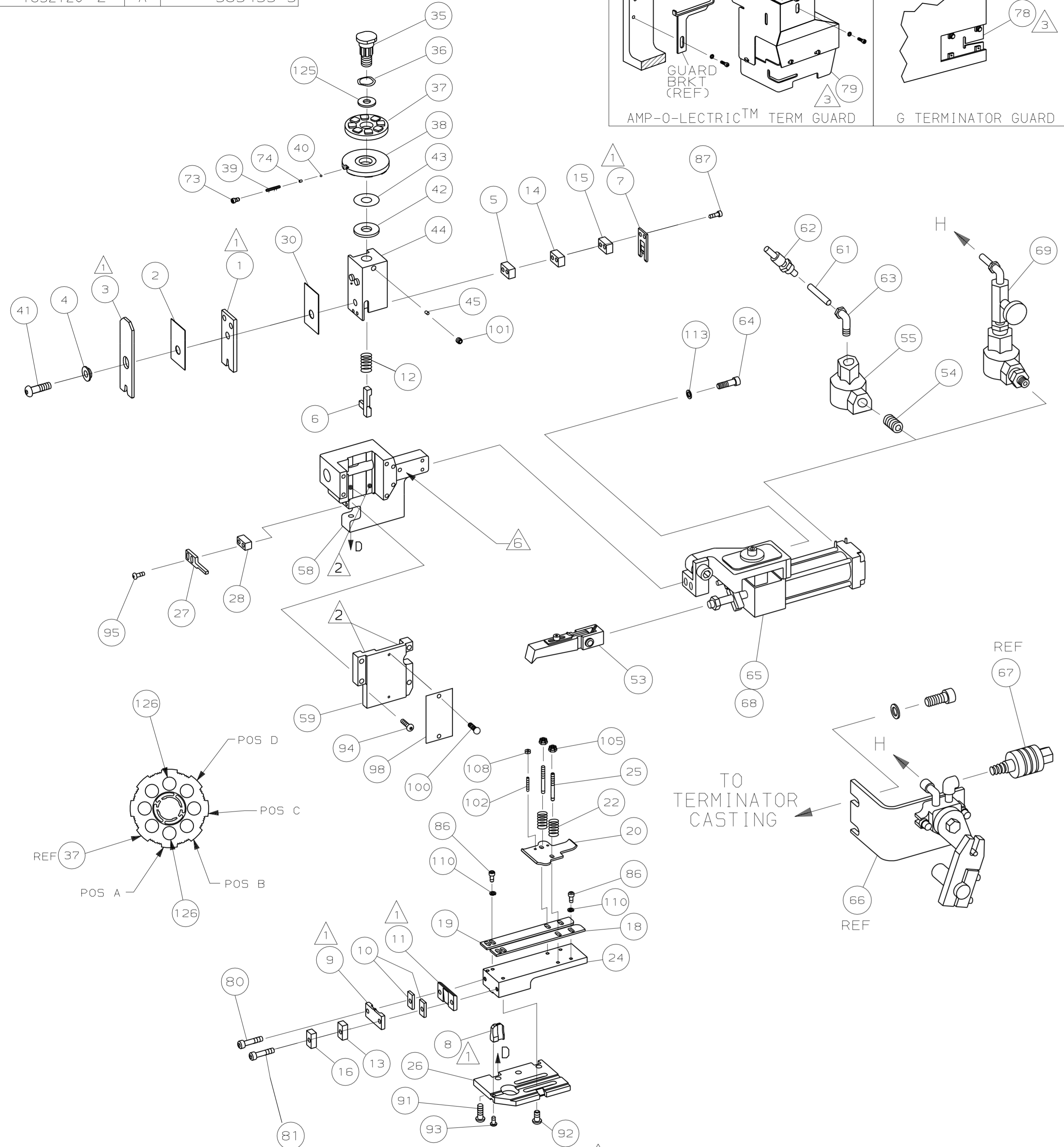
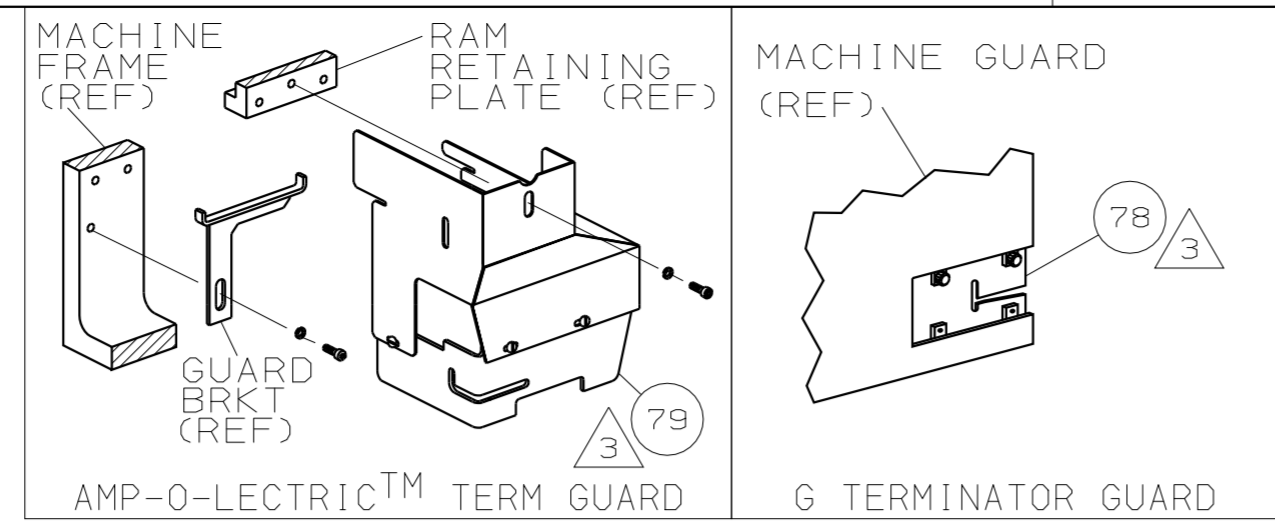

- ① RECOMMENDED SPARE PARTS.
- ② GREASE LIGHTLY.
- ③ GUARD MUST BE IN PLACE WHEN OPERATING APPLICATOR IN A BENCH MACHINE.
- ④ SEE DRAWING FOR COMPONENTS
- ⑤ ITEM 78 USED WITH G TERMINATOR ONLY.
- ⑥ REMOVE PIN AT ASSEMBLY

TERMINAL NAME: RING		AMETEK TERMINAL		CUST CRIMP SPECS		
AMP	TERM PN	MFR	TERM PN	PAD LTR	CRIMP HEIGHT	WIRE SIZE
1572787	20-5124			A	.061 ±.002 [1.55 ±0.05mm]	18
				B	NOT	USED
				C	NOT	USED
				D	NOT	USED
		CRIMP	SIZE	TYPE	RANGE	
		WIRE	.100 [2.54mm]	F	18	
		INSUL	.160 [4.06mm]	F	.110 MAX	
WIRE STRIP LENGTH	TERM APPL	SPEC	FEED	APPL INSTRUCTION	SET UP GAGE	LAYOUT
.170-.200	NONE		1.380	408-8039	458638-1	L1852120

QTY	REV	U/M	DWG SIZE	PART NO	DESCRIPTION	ITEM NO
						129
						128
						127
						126
2	2	-	C	1-354779-6	PIN, WIRE DISC (.3070)A	126
1	1	-	A	986950-1	WASHER, FLAT PRECISION	125
1	1	-	A	217238-1	GENERAL INSTRUCTION PACKAGE	124
1	1	-	-	4088039	EF APPL INST 408-8039	123
						122
						121
						120
						119
						118
						117
						116
						115
						114
2	2	-	A	21024-5	WASHER, LOCK (#10) AIR ASSY	113
						112
						111
4	4	-	A	21024-4	WASHER, LOCK (NO.8) SHEAR BL	110
						109
2	2	-	A	21018-4	NUT, HEX (4-40) DRAG	108
						107
						106
2	2	-	A	21022-2	NUT, HEX SL (8-32) DRAG STUD	105
						104
						103
2	2	-	A	2-21006-6	SCR, SKT SET (4-40x.62) DRAG	102
1	1	-	A	21009-2	SCR, SKT SET (1/4-20x.25 )RAM	101
2	2	-	A	21017-2	SCR, DRIVE (#2x.19) ID PLATE	100
						99
1	1	-	B	461264-1	PLATE, IDENTIFICATION	98
						97
						96
2	2	-	A	2-21002-2	SCR, BHC (8-32x.50) STRIPPER	95
4	4	-	A	2-21002-9	SCR, BHC (10-32x.75) CAP	94
1	1	-	A	22733-8	SCR, BHC (8-32x.38 LW) ANVIL	93
4	4	-	A	3-21002-3	SCR, BHC (1/4-20x.50) ST GD PL	92
3	3	-	A	2-22733-8	SCR, BHC (1/4-20x.62) H5G	91
						90
						89
						88
						87
						86
						85
						84
						83
						82
1	1	-	A	4-21000-1	SCR, SHC (10-32x1.50) SHEAR PL	81
1	1	-	A	3-21000-8	SCR, SHC (10-32x.88) SHEAR PL	80
1	-	-	A	455750-8	GUARD ASSY	79
-	REF	-	A	679532-1	INSERT, GUARD	78
						77
						76
						75
1	1	-	A	690603-1	SPRING, ASSIST	74
1	1	-	A	23030-1	SCR, SKT CAP (6-32x.25) CP DSC	73
						72
						71

QTY	REV	U/M	DWG SIZE	PART NO	DESCRIPTION	ITEM NO
-2	-1					

QTY	REV	U/M	DWG SIZE	PART NO	DESCRIPTION	ITEM NO	
						70	
						69	
						68	
						67	
						66	
						65	
						64	
						63	
						62	
						61	
						60	
1	1	-	C	454220-1	CAP, RAM	59	
1	1	-	D	453736-1	HOUSING	58	
						57	
						56	
						55	
						54	
						53	
						52	
						51	
						50	
						49	
						48	
						47	
						46	
1	1	-	A	690191-1	PLUG, NYLON	45	
1	1	-	C	455674-1	RAM	44	
1	1	-	A	690125-1	WASHER, LAMINATED	43	
1	1	-	A	690124-1	WASHER, RAM	42	
1	1	-	A	7-21002-9	BOLT, CRIMPER (5/16-24x1.00)	41	
1	1	-	A	23241-6	BALL, STEEL	40	
1	1	-	A	690170-1	SPRING, COMPRESSION	39	
1	1	-	C	690142-1	DISC, INSULATION	38	
1	1	-	D	354777-1	DISC, WIRE	37	
1	1	-	A	22480-5	WASHER, SPRING	36	
1	1	-	B	690212-1	POST, RAM	35	
						34	
						33	
						32	
						31	
1	1	-	B	455888-1	SPACER, CRIMPER	30	
						29	
1	1	-	B	3-690451-2	SPACER, STRIPPER	28	
1	1	-	A	240639-1	STRIPPER	27	
1	1	-	D	455676-2	PLATE, BASE	26	
2	2	-	A	22354-8	DRAG, STUD	25	
1	1	-	B	1-455678-8	PLATE, STRIP GUIDE	24	
						23	
2	2	-	A	4-22281-1	SPRING, DRAG	22	
						21	
1	1	-	A	454177-3	DRAG, STOCK	20	
1	1	-	B	5-458030-9	GUIDE, STRIP (REAR)	19	
1	1	-	C	6-458031-0	GUIDE, STRIP (FRONT)	18	
						17	
1	1	-	C	1-690481-2	SPACER, HOLD DOWN	16	
1	1	-	C	4-240641-7	SPACER, SLUG BLADE	15	
1	1	-	C	6-240641-5	SPACER, SLUG BLADE	14	
1	1	-	C	3-690481-1	SPACER, HOLD DOWN	13	
1	1	-	A	23846-1	SPRING, HOLD DOWN	12	
④	1	1	-	B	240644-1	PLATE, REAR SHEAR	11
④	2	2	-	C	1-240645-2	SPACER, SHEAR PLATE	10
④	1	1	-	B	240642-5	PLATE, FRONT SHEAR	9
④	1	1	-	D	8-356038-3	ANVIL	8
④	1	1	-	B	1-240651-1	BLADE, SLUG	7
						6	
						5	
						4	
						3	
						2	
④	1	1	-	C	2-456407-0	CRIMPER, WIRE	1

QTY	REV	U/M	DWG SIZE	PART NO	DESCRIPTION	ITEM NO
-2	-1					

REVISION OF EACH ASSY NO (WHEN BLANK, USE DWG REVISION)

DR C. REICHELDERFER  
CHK -  
1 95SEP05  
2 PLC DEC ±.25  
3 PLC DEC ±  
4 PLC DEC ±

REL -  
1 T. ELBIN  
2

AMP Tyco Electronics  
Harrisburg, PA 17105-3608

NAME: END FEED HDM APPLICATOR  
SCALE: -  
DWG NO: 1852120

MACHINE REF: MINI APPL  
SHEET: 1 OF 1  
REV: A

REMOVE BURRS, BREAK SHARP EDGES R.015 MAX

CAGE CODE: 00779

CUSTOMER AND ASSEMBLY DRAWING

THIS DRAWING IS A CONTROLLED DOCUMENT.

THIS DRAWING IS UNPUBLISHED.  
RELEASED FOR PUBLICATION  
BY AMP INCORPORATED. ALL RIGHTS RESERVED.  
LOC A  
DIST 66  
AMP 1756 REV 3-92