

PART NUMBER	REV	FIRST USED
680723-1	B	122500-1
680723-2	B	565435-5
680723-3	B	354500-1

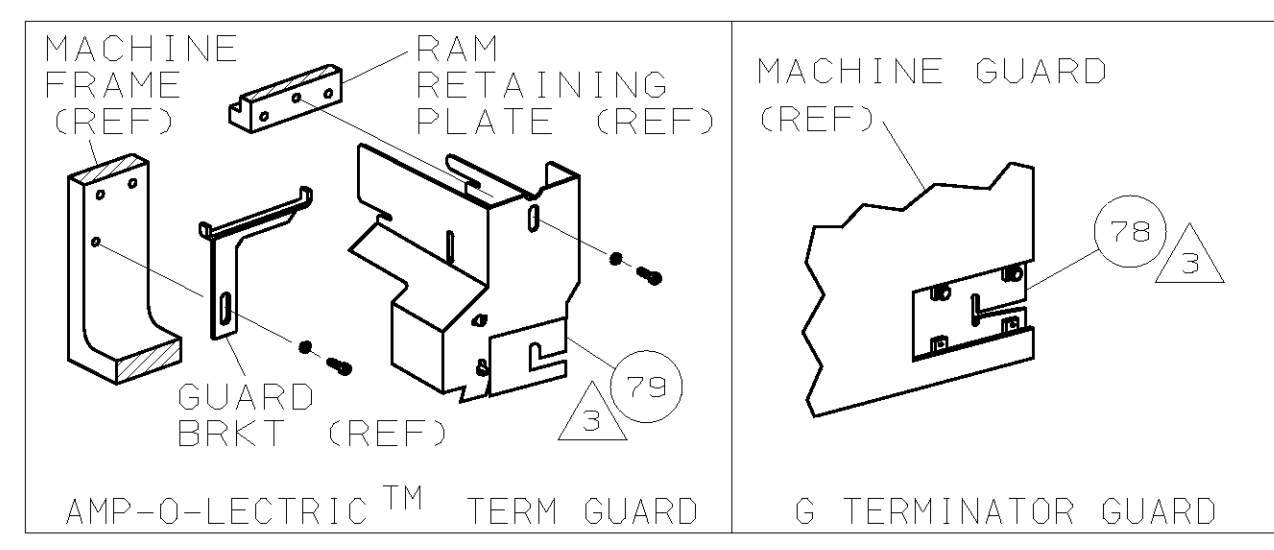
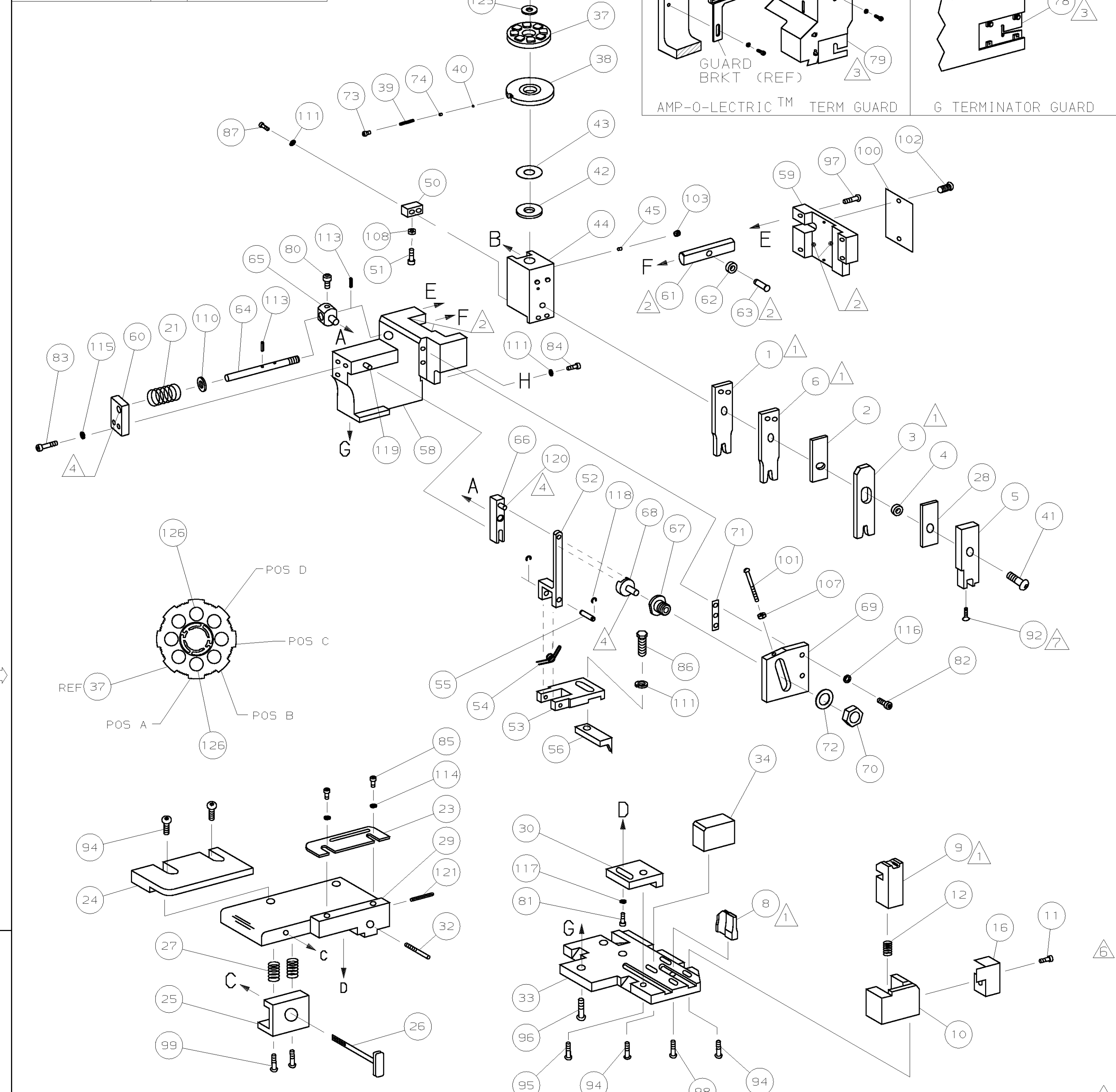

SEAL	TERMINAL	CRIMP DATA (NON-AMP TERMINAL-MFR SPEC)
286653	286761	PAD LTR CRIMP HEIGHT WIRE SIZE
AMP	MFG	A .049 ±.002 [1.24 ±0.05mm] 18
286761	12066638	B NOT USED
		C NOT USED
		D NOT USED
SEAL	TERMINAL	CRIMP SIZE TYPE RANGE
286653	12015359	WIRE .094 [2.39mm] F 18
		INSUL .170 [4.32mm] 0 Ø.110-.137

WIRE STRIP LENGTH	TERM APPL SPEC	FEED	APPL INSTRUCTION	SET UP GAGE	LAYOUT	ITEM NO
.203-.234	NONE	.790	408-8040	458637-1	L2145	129
						128
						127
2	2	2	-	C	3-354779-8	PIN, WIRE DISC (.3180)A 126
1	1	1	-	A	986950-1	WASHER, FLAT PRECISION 125
1	1	1	-	A	217238-1	GENERAL INSTRUCTION PACKAGE 124
1	1	1	-	-	4088040	SF APPL INST 408-8040 123
						122
1	1	1	-	A	4-21028-0	PIN, SLT SPR (Ø.093x.75) ST GDE PL 121
REF	REF	REF	-	A	1-21030-1	PIN, DOWEL (Ø.187x.50) LEVER 120
REF	REF	REF	-	A	1-21030-6	PIN, DOWEL (Ø.187x1.25) HOUSING 119
REF	REF	REF	-	A	21045-3	RING, RET "C" (Ø.187) FD FING PIN 118
1	1	1	-	A	21024-5	WASHER, LOCK (#10) ADJ BLK 117
REF	REF	REF	-	A	21024-5	WASHER, LOCK (#10) ADJ PLATE 116
REF	REF	REF	-	A	21024-5	WASHER, LOCK (#10) FEED GDE ROD 115
2	2	2	-	A	21024-2	WASHER, LOCK (#4) FRONT STP GUIDE 114
REF	REF	REF	-	A	5-21028-1	PIN, SLT SPR (Ø.125x.50) ADJ ROD 113
						112
4	4	4	-	A	21024-4	WASHER, LOCK (#8) STRIPPER 111
REF	REF	REF	-	A	21899-4	WASHER, FLAT (Ø5/16) SCREW ADJ 110
						109
1	1	1	-	A	21018-5	NUT, HEX (NO. 6) HOLDDOWN 108
REF	REF	REF	-	A	21068-5	NUT, HEX (6-32) FEED ADJ 107
						106
						105
1	1	-	-	A	992031-1	PIN, CLEVIS 104
1	1	1	-	A	21009-2	SCR, SKT 5ET (1/4-20x.25 LW) RAM 103
2	2	2	-	A	21017-2	SCR, DRIVE (#2x.19) ID PLATE 102
REF	REF	REF	-	A	6-23715-5	SCR, PAN HD (6-32x1.50) FEED ADJ 101
1	1	1	-	B	461264-1	PLATE, IDENTIFICATION 100
2	2	2	-	A	3-21002-0	SCR, BHC (10-32x.88) DRAG 99
1	1	1	-	A	22733-8	SCR, BHC (8-32x.38 LW) ANVIL 98
REF	REF	REF	-	A	2-21002-9	SCR, BHC (10-32x.75) CAP 97
REF	REF	REF	-	A	2-22733-8	SCR, BHC (1/4-20x.62) HOUSING 96
REF	REF	REF	-	A	2-21002-7	SCR, BHC (10-32x.50) 56 ADJ BLOCK 95
6	6	6	-	A	2-21002-2	SCR, BHC (8-32x.50) TERM H DWN 94
						93
1	1	1	-	A	1-21003-9	SCR, FHC (6-32x.38) DEP 92
1	1	1	-	A	1-21002-7	SCR, BHC (6-32x.38) CAM 91
						90
1	1	-	-	A	7-21000-9	SCR, SHC (4-40x.19) STRIPPER 89
						88
2	2	2	-	A	2-21000-7	SCR, SHC (8-32x.48) DEP-HOLD 87
1	1	1	-	A	2-22603-0	SCR, HEX HD (8-32x.31) FEED FINGER 86
2	2	2	-	A	1-21000-3	SCR, SHC (4-40x.25) F ST GUIDE 85
1	1	1	-	A	2-21000-7	SCR, SHC (8-32x.50) STRIPPER 84
REF	REF	REF	-	A	3-21000-7	SCR, SHC (10-32x.75) FEED ROD GD 83
REF	REF	REF	-	A	3-21000-6	SCR, SHC (10-32x.62) FD ADJ BLK 82
1	1	1	-	A	3-21000-4	SCR, SHC (10-32x.38) 56 ADJ BL 81
REF	REF	REF	-	A	3-21000-4	SCR, SHC (10-32x.38) PIVOT BLK 80
-	REF	-	-	B	455749-1	GUARD, WINDOW 79
REF	-	-	-	B	679532-1	INSERT, GUARD 78
						77
						76
						75
1	1	1	-	A	690603-1	SPRING, ASSIST 74
1	1	1	-	A	23030-1	SCR, SHC (6-32x.25 SL) INS DISC 73
REF	REF	REF	-	A	458109-1	WASHER, SPECIAL 72
REF	REF	REF	-	A	690517-1	SPACER 71
						70
						69
						68
						67
						66
						65
						64
						63
						62
						61
						60
						59
						58
						57
						56
1	1	1	-	B	1-694433-1	PAWL, FEED 55
REF	REF	REF	-	B	240624-1	PIN, FEED FINGER 54
REF	REF	REF	-	B	691499-1	SPRING, FEED FINGER 53
REF	REF	REF	-	B	690541-1	HOLDER, FEED FINGER 52
REF	REF	REF	-	A	455679-2	LEVER, TERMINAL FEED ARM 51
1	1	1	-	A	811242-2	BUMPER, HOLDDOWN 50
1	1	1	-	A	690753-1	SPACER, TONKER 49
1	-	-	-	B	690602-6	CAM, PRE-FEED 1 5/8 ST 48
-	1	-	-	B	690602-5	CAM, PRE-FEED 1 1/8 ST 47
-	-	1	-	B	690501-4	CAM, POST-FEED 1 5/8 ST 46
1	1	1	-	B	459456-2	APPLICATOR, BASIC (SUBASSY) 45
1	1	1	-	A	690191-1	PLUG, NYLON 44
1	1	1	-	C	455673-5	RAM 43
1	1	1	-	A	690125-1	WASHER, LAMINATED 42
1	1	1	-	A	690124-1	WASHER, RAM 41
1	1	1	-	A	7-21002-9	BOLT, CRIMPER (5/16x1.00) 40
1	1	1	-	A	23241-6	BALL, STEEL 39
1	1	1	-	A	690170-1	SPRING, COMPRESSION 38
1	1	1	-	C	690142-1	DISC, INSULATION 37
1	1	1	-	D	354777-1	WIRE DISC, PLASTIC 36
1	1	1	-	A	22480-5	WASHER, SPRING 35
1	1	1	-	B	690212-1	POST, RAM 34
1	1	1	-	B	690786-1	SUPPORT, TERMINAL 33
REF	REF	REF	-	D	455675-1	PLATE, BASE 32
1	1	1	-	A	690432-3	SCREW, ADJUSTMENT 31
						30
REF	REF	REF	-	B	455689-1	BLOCK, STRIP GUIDE ADJ 29
1	1	1	-	C	455671-1	PLATE, STRIP GUIDE 28
1	1	1	-	C	1-455888-7	SPACER, FRONT SHEAR DEP 27
2	2	2	-	A	1-22284-0	SPRING, DRAG 26
1	1	1	-	B	690546-1	LEVER, DRAG RELEASE 25
1	1	1	-	B	240792-1	DRAG, TERMINAL 24
1	1	1	-	D	1-90765-2	GUIDE, STRIP (REAR) 23
1	1	1	-	A	690438-1	GUIDE, STRIP (FRONT) 22
-	-	1	-	B	690472-2	STRIPPER 21
REF	REF	REF	-	A	4-22284-9	SPRING, FEED RETURN 20
1	1	-	-	A	679218-1	STRIPPER WIRE STOP ASSY 19
1	1	-	-	B	458949-1	STRIPPER 18
						17
						16
1	1	1	-	B	318563-1	GUARD, CHIP, FRONT 15
						14
						13
1	1	1	-	A	5-22280-0	SPRING, SHEAR 12
1	1	1	-	B	690461-2	STOP, SHEAR 11
1	1	1	-	C	1-690459-0	HOLDER, SHEAR (FRONT) 10
1	1	1	-	C	318707-2	SHEAR, FLOAT (FRONT) 9
1	1	1	-	C	2-662520-6	ANVIL 8
						7
						6
1	1	1	-	C	3-568176-2	CRIMPER, WIRE 5
1	1	1	-	C	318701-1	DEPRESSOR, SHEAR (FRONT) 4
1	1	1	-	B	238011-8	SPACER, BLOCK CRIMPER 3
1	1	1	-	C	7-683454-7	CRIMPER, INSULATION 2
1	1	1	-	C	1-455888-7	SPACER, CRIMPER 1
1	1	1	-	C	3-568176-1	CRIMPER, WIRE

QTY	RECD	PER	ASSY	PARTS LIST	ITEM NO	
					129	
					128	
					127	
2	2	2	-	C	3-354779-8	PIN, WIRE DISC (.3180)A 126
1	1	1	-	A	986950-1	WASHER, FLAT PRECISION 125
1	1	1	-	A	217238-1	GENERAL INSTRUCTION PACKAGE 124
1	1	1	-	-	4088040	SF APPL INST 408-8040 123
					122	
1	1	1	-	A	4-21028-0	PIN, SLT SPR (Ø.093x.75) ST GDE PL 121
REF	REF	REF	-	A	1-21030-1	PIN, DOWEL (Ø.187x.50) LEVER 120
REF	REF	REF	-	A	1-21030-6	PIN, DOWEL (Ø.187x1.25) HOUSING 119
REF	REF	REF	-	A	21045-3	RING, RET "C" (Ø.187) FD FING PIN 118
1	1	1	-	A	21024-5	WASHER, LOCK (#10) ADJ BLK 117
REF	REF	REF	-	A	21024-5	WASHER, LOCK (#10) ADJ PLATE 116
REF	REF	REF	-	A	21024-5	WASHER, LOCK (#10) FEED GDE ROD 115
2	2	2	-	A	21024-2	WASHER, LOCK (#4) FRONT STP GUIDE 114
REF	REF	REF	-	A	5-21028-1	PIN, SLT SPR (Ø.125x.50) ADJ ROD 113
					112	
4	4	4	-	A	21024-4	WASHER, LOCK (#8) STRIPPER 111
REF	REF	REF	-	A	21899-4	WASHER, FLAT (Ø5/16) SCREW ADJ 110
					109	
1	1	1	-	A	21018-5	NUT, HEX (NO. 6) HOLDDOWN 108
REF	REF	REF	-	A	21068-5	NUT, HEX (6-32) FEED ADJ 107
					106	
					105	
1	1	-	-	A	992031-1	PIN, CLEVIS 104
1	1	1	-	A	21009-2	SCR, SKT 5ET (1/4-20x.25 LW) RAM 103
2	2	2	-	A	21017-2	SCR, DRIVE (#2x.19) ID PLATE 102
REF	REF	REF	-	A	6-23715-5	SCR, PAN HD (6-32x1.50) FEED ADJ 101
1	1	1	-	B	461264-1	PLATE, IDENTIFICATION 100
2	2	2	-	A	3-21002-0	SCR, BHC (10-32x.88) DRAG 99
1	1	1	-	A	22733-8	SCR, BHC (8-32x.38 LW) ANVIL 98
REF	REF	REF	-	A	2-21002-9	SCR, BHC (10-32x.75) CAP 97
REF	REF	REF	-	A	2-22733-8	SCR, BHC (1/4-20x.62) HOUSING 96
REF	REF	REF	-	A	2-21002-7	SCR, BHC (10-32x.50) 56 ADJ BLOCK 95
6	6	6	-	A	2-21002-2	SCR, BHC (8-32x.50) TERM H DWN 94
					93	
1	1	1	-	A		