

SEZIONE C-C

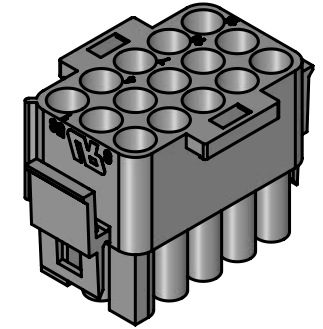

DETTAGLIO G
SCALA 5:1

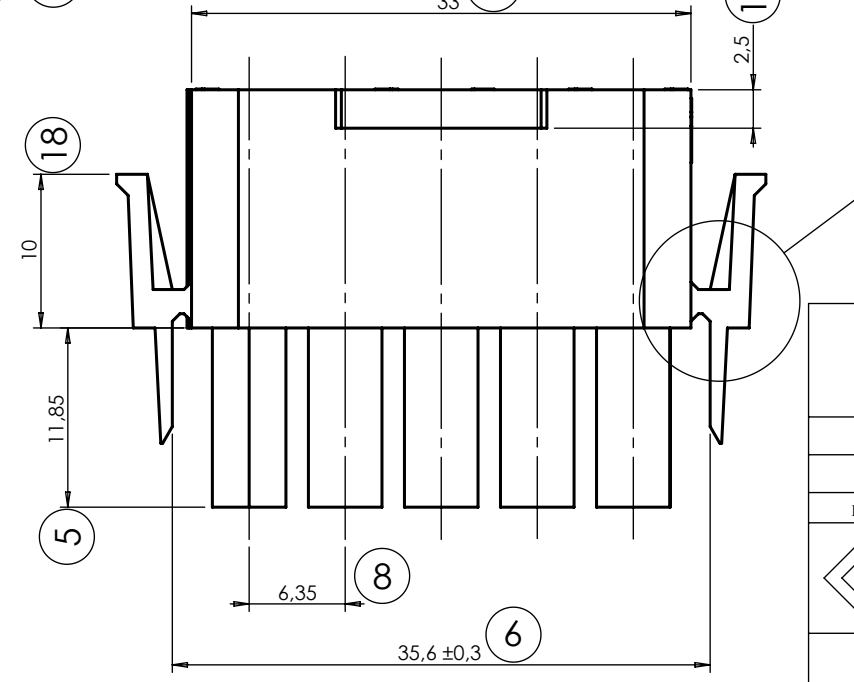
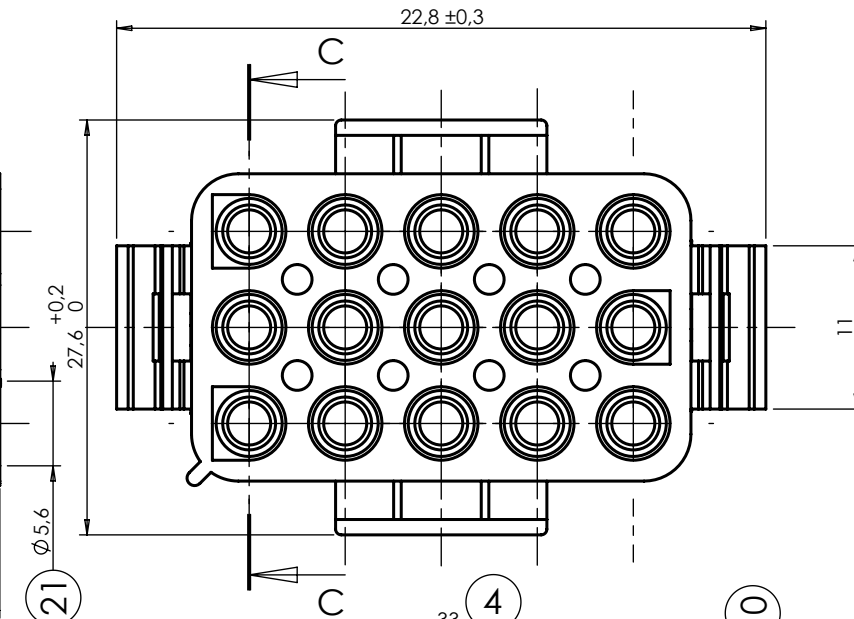
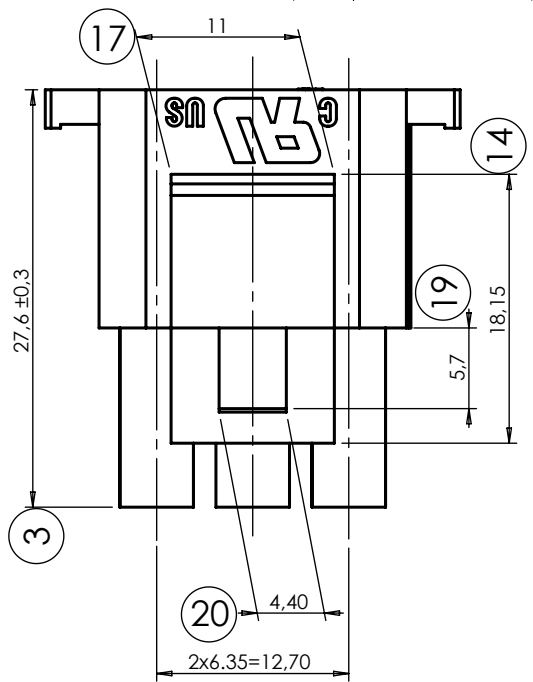
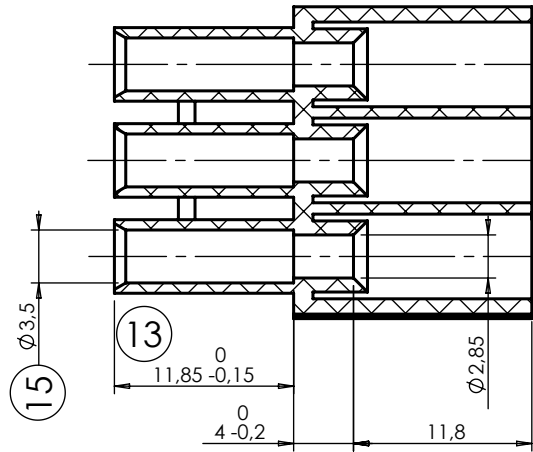
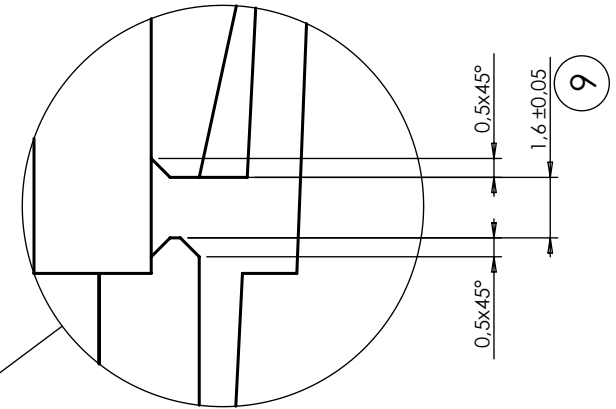
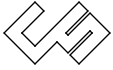
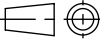

3	Modified diameters from $\varnothing 3.75$ to $\varnothing 3.50$ mm (See section C-C)	14-06-2017
	Improved thickness latching hook to 1.60 mm (See detail "G")	
	Added chamfer 0.5x45° (Detail "G")	
2	Aggiornata lista materiali termoplastici	05-05-2009
1	Modificate tolleranze generali	06-06-2001
INDEX	MODIFICATION	DATE
 CS S.r.l. 20063 CERNUSCO S/N - VIA COMO, 11 TEL +39.02.9210.7404 - FAX +39.02.9210.0217 http://www.csconnectors.com - e-mail: info@csconnectors.com		 DESIGN UNITS METRIC
CHECKED BY Stefano Galimberti		DATE DESIGN UNITS METRIC
DRAWN BY Luca Viscardi		DATE WEIGHT (g) 5.70
CAD REFER Y:\dis\cs\lk\15vie\m\		SIZE A4
SCALE 2:1		INDEX 0 10-11-1998
BASE CODE	DESCRIPTION	
CS-LK15M	Giunto 15 vie per terminale maschio $\varnothing 2.12$ mm	

DIMENSIONS WITHOUT TOLERANCES		CS-LK15M	PA66 UL94 V-2	
A ±2°	0 - 6	±0.1	CS-LK15MV0	PA68 UL94 V-0
	6 - 30	±0.2	CS-LK15MV0750NF	PA66 UL94 V-0 GWIT 775
	> 30	±0.3	CS-LK15M-G	PA6 UL94 V-2 GWIT 775
		PART NUMBER	MATERIAL	