

PART NAME: HANDLE SCALE: 1:1 DATE: 9/12/85 DR. BY HD

THIS DRAWING IS THE PROPERTY OF DAVIES MOLDING COMPANY, IS SUBMITTED SOLELY AS A DESIGN OR ENGINEERING PROJECT. WE ACCEPT NO RESPONSIBILITY WHATSOEVER FOR THE PRACTICAL APPLICATION OF THE PIECES MADE TO THIS DESIGN.



DESIGNERS & MANUFACTURERS OF KNOBS, HANDLES, CASES & CUSTOM PLASTIC COMPONENTS

P/N 3094-G

MNO. FRAME # 27

CAVITY	3094
CORE	3094
EJECTOR PIN	3094
© CORE PLUG	3094
Ⓔ INSERT	I0468

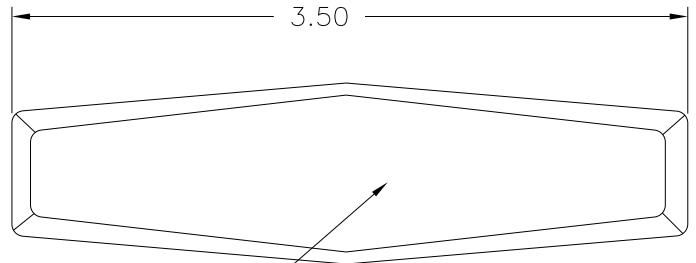

TEXTURED AREA-TOP SURFACE OF KNOB & OUTER SURFACES UPTO PARTING LINE (RE-6320)

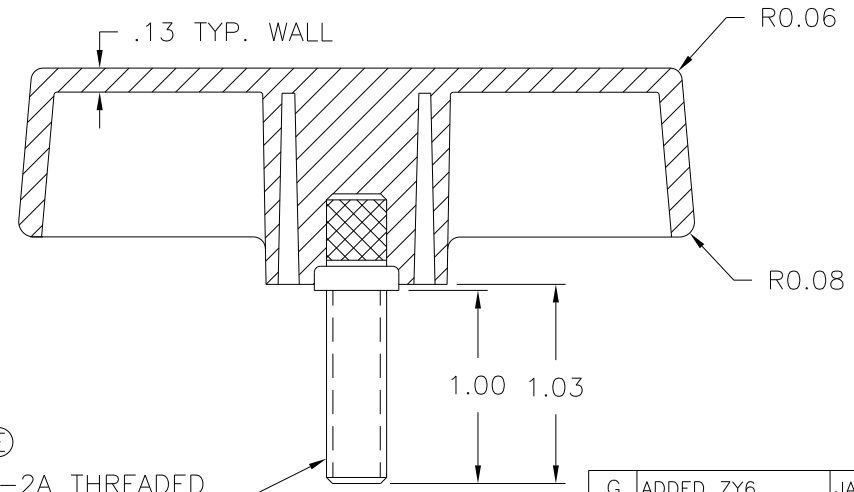
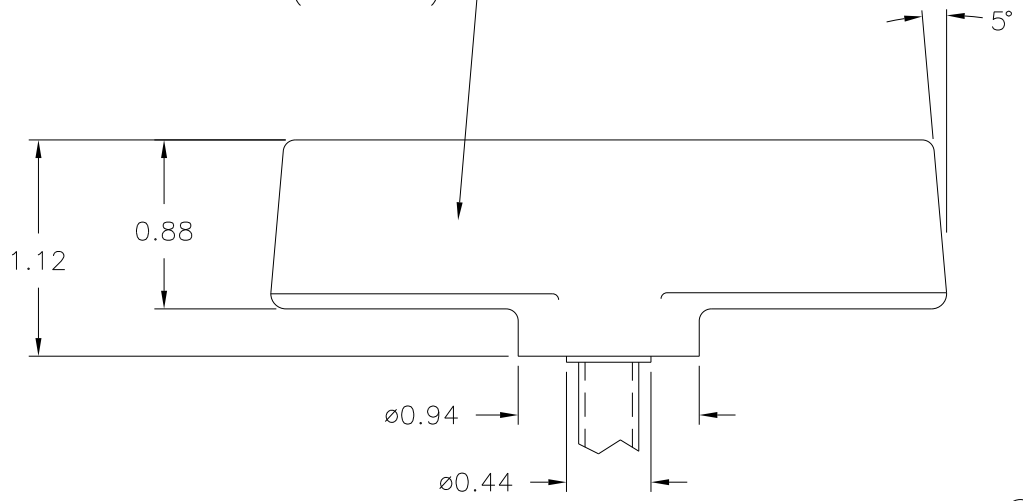

NOTE : TUBE (T0135) TO BE INSTALLED ON ALL MOLDED PARTS

Ⓔ 5/16-18 UNC-2A THREADED I0468, STEEL, ZINC PLATED

Ⓒ MATERIAL: NYLON 6/6 (ZY2), (ZY6) OR ENGINEERING APPROVED EQUIVALENT
 COLOR: BLACK

G	ADDED ZY6	JAM	7/13/12
F	ADDED MAT. CODE	DS	1/9/07
E	WAS I1510	TL	8/9/99
D	WAS POLYPRO.	HD	2/21/97
-	CAD/REDRAWN	HD	1/30/96
C	CORE PLUG WAS 3094-N	HD	1/11/91
B	CORING DETAIL ADDED	HD	1/28/89
A	WAS I0441	HD	4/14/88

TOLERANCES: UNLESS OTHERWISE SPECIFIED	DO NOT SCALE DRAWING
DECIMALS: X.XXX ± .005 X.XX ± .015	MM: X.XX ± 0.15MM X.X ± 0.4MM
FRACTIONS ± 1/64	ANG. ± 1°

CHANGES