

MATERIALS & SPECIFICATIONS

PART NO.	A28100-025	REV	ECO	DATE	01-30-10	APP	TLM
			G	96463			

HOUSING:
ALUMINUM 6061-T6, NICKEL
PLATE PER AMS-C-26074

INSULATOR:
LIQUID CRYSTAL POLYMER (LCP)
PER ASTM D5138

CONTACT:
BERYLLIUM COPPER PER ASTM
B194, C17200, GOLD PLATED
PER ASTM B488, (HARD GOLD)
TYPE II CODE C, CLASS 1.27

TERMINATION:
SOLDER COATED WITH SN63A PER
J-STD-006 OR AMS-P-81728

CURRENT RATING:
1 AMP MAX PER MIL-DTL-32139

CONTACT RESISTANCE:
71 MILLIOHM MAX (71mV DROP
MAX) @ 1.0 AMPS PER MIL-
DTL-32139

PERFORMANCE:
PRODUCT FAMILY TESTED TO AND
PASSED THE PERFORMANCE
SPECIFICATIONS OF TABLE VIII OF
MIL-DTL-32139

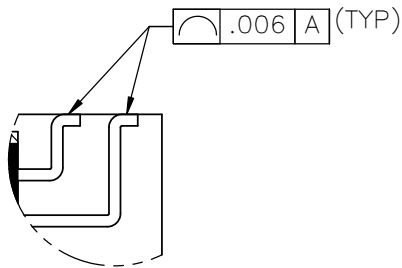
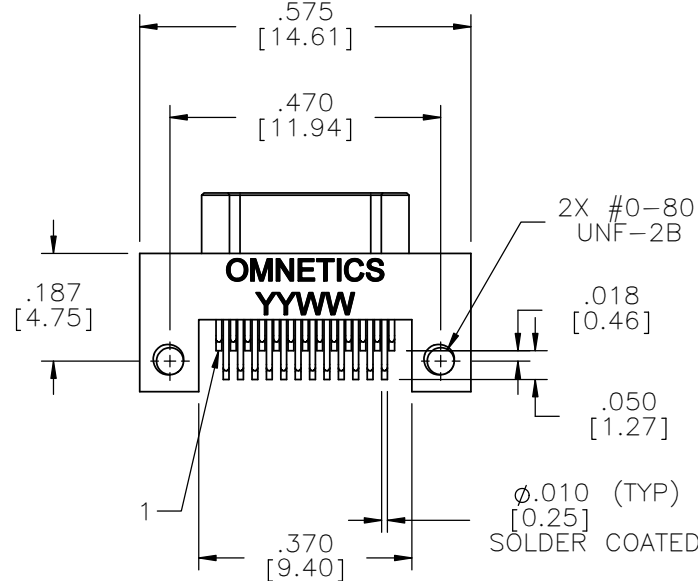
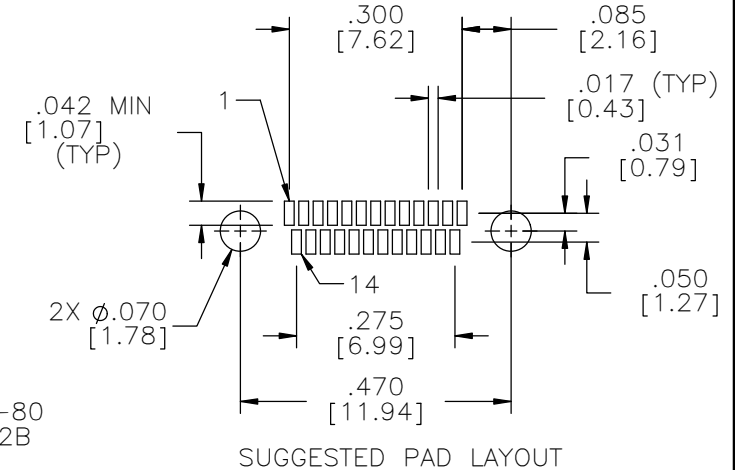
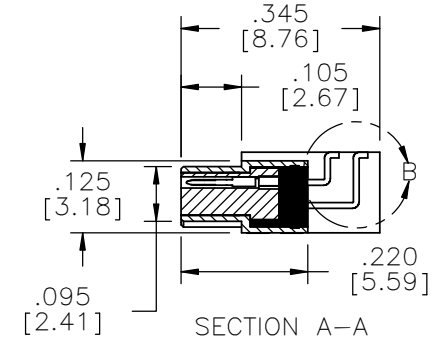
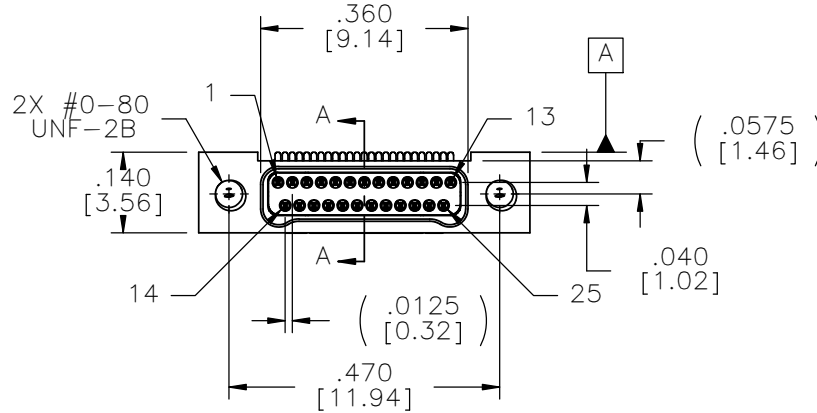

DETAIL B
SCALE 6 : 1

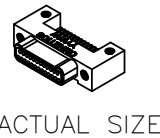

ACTUAL SIZE

MNP/SLDW	THIRD ANGLE	THIS DRAWING CONTAINS CONFIDENTIAL AND PROPRIETARY INFORMATION WHICH IS THE PROPERTY OF OMNETICS CONNECTOR CORP. THIS DOCUMENT MAY NOT, IN WHOLE OR IN PART, BE DUPLICATED, OR DISCLOSED FOR ANY PURPOSE, WITHOUT WRITTEN PERMISSION FROM OMNETICS CONNECTOR CORP.
	-TOLERANCES-	
	UNLESS OTHERWISE NOTED	
	DIMENSIONS IN INCHES	
	2 PL DEC ± .01	DFTM. AAS
	3 PL DEC ± .005	DATE 05-05-04
	4 PL DEC ± .0005	CHK'D.
	ANGLES ± 1°	DATE
		APP'D.
		DATE

TITLE:	(25) PIN MALE Bi-Lobe® CONNECTOR
--------	-------------------------------------

OMNETICS
CONNECTOR CORPORATION
7260 COMMERCE CIRCLE EAST
MINNEAPOLIS, MN 55432
WWW.OMNETICS.COM

CAGE CODE	61873
DWG NO.	A28100-025
SHEET 1 OF 1	REV G
SCALE:	3:1