

1

2

3

4

5

6

7

A

B

C

D

E

F

G

H

A

B

C

D

E

F

G

H

P1

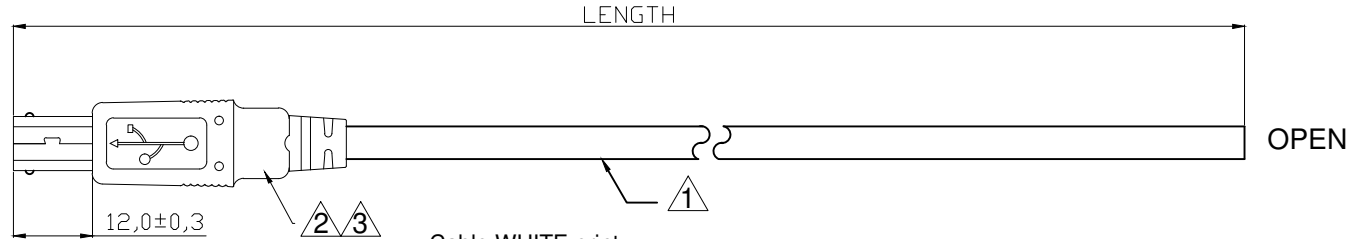
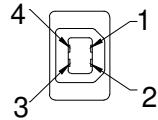

12,0±0,3

Cable WHITE print
 AWM STYLE 2725 80°C 30V VW-1 28AWG/1P 28AWG/2C
 ---c AWM I/II A 80°C 30V FT1 USB CABLE

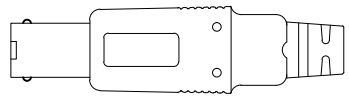

PE Bag Packing

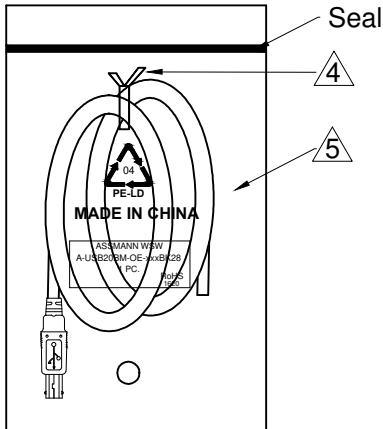

1PC/PE Bag

PIN ASSIGNMENT

P1		OPEN
1	Red	OPEN
2	White	OPEN
3	Green	OPEN
4	Black	OPEN
Shell	Drain+Braid	OPEN

TEST CONDITION:

- 1.100% OPEN, SHORT, MISWIRE TEST
- 2.CONDUCT RESISTANCE : 2 Ω Max
- 3.INSULATION RESISTANCE: 5M Ω Min
- 4.Dielectric test:300V DC

WSW P/N	Length(mm)	PE BAG SIZE
A-USB20BM-OE-050BK28	500±30	100*200*0.05mm
A-USB20BM-OE-100BK28	1000±30	100*200*0.05mm
A-USB20BM-OE-200BK28	2000±50	130*230*0.05mm
A-USB20BM-OE-300BK28	3000±50	130*230*0.05mm
A-USB20BM-OE-500BK28	5000±50	150*280*0.05mm

NO.	NAME.	Q'TY	SPECIFICATION
5	PE Bag	1	CLEAR PRINT BLACK"MADE IN CHINA"+"1PC."
4	TIE	1	white L=120mm
3	Over Molding	NA	PVC 45P Black
2	CONN	1	USB B MALE SHELL: Nickel PIN:G/F Insulator color:White
1	Cable	1	USB2.0 UL2725 28#/1P+28#/2C+AEB OD:3.8mm,PVC Jacket Black

RoHS compliant
Unit: mm

Scale	Free					Date	Name	Customer-No.
TOLERANCE						Drawn	09.10.2018	Xavier
						Approved	09.10.2018	Winnie
DIM	TOL							ASSMANN WSW-No. A-USB20BM-OE-xxxBK28
		①	Drawn	09.10.2018	Xavier			Drawing-No. ASS 8367 CA
Angle	TOL	Id.	Modification	Date	Name			Replace

1

2

3

4

5

6

7

Cable Wrapping Spec.

Cable Length(L)	Wrapping Dimension
L≤1M	W:80*L:100mm(MAX)
1M<L≤2M	W:85*L:105mm(MAX)
2M<L≤3M	W:120*L:150mm(MAX)
3M<L≤5M	W:150*L:180mm(MAX)

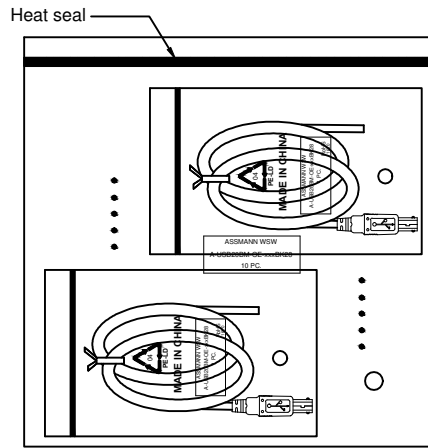
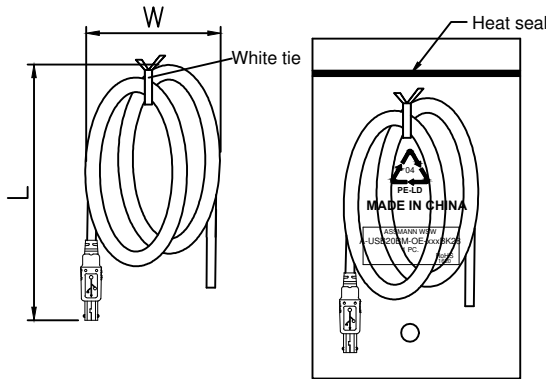

10PCS/Middle PE bag
Post 1PCS label on middle PE bag

Content of the label on middle PE bag:

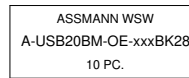

Packing information:

- 1).Wrapping 1pcs cable, then tying.
- 2).Packing 1pcs finished goods into 1pcs samll PE bag.
- 3).Packing 10pcs small PE bag into 1pcs middle PE bag.
- 4).Place 1pcs water-proof PE bag into carton and 1pcs paperboard in bottom and top of carton respectively.
- 5).Carton spec.: 40*30*25CM

Code label posted onto carton side

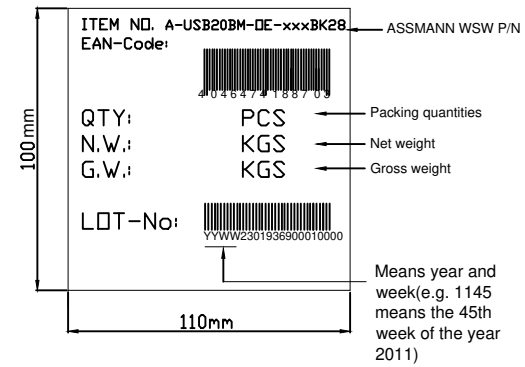

Code label posted onto left front corner of carton side x2 (on both side)

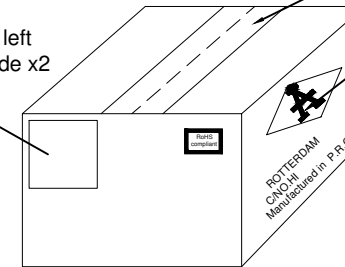

Sealing adhesive tapes

REQUIREMENT FOR FRONT SIDE OF CARTON
PORT.NAME:
(by sea) ROTTERDAM
(by air) COLOGNE
(by Fedex or UPS) Ludenscheid

Content of the label on small PE bag:

ASSMANN WSW	Consistent
A-USB20BM-OE-xxxBK28	ASSMANN WSW P/N
1 PC.	Consistent
RoHS 1620	Consistent

NOTES: e.g. 1620-16 means Year 2016 , 20 means the 20th week of the year 2016

RoHS compliant
Unit: mm

Scale	Free				Date	Name	Customer-No.
TOLERANCE					Drawn	09.10.2018	Xavier
					Approved	09.10.2018	Winnie
DIM	TOL						ASSMANN WSW-No. A-USB20BM-OE-xxxBK28
		ⓐ	Drawn	09.10.2018	Xavier	Drawing-No. ASS 8367 CA rev00	
Angle	TOL	Id.	Modification	Date	Name	Replace	Sheet 2/2

