

Lxx08xx & Qxx08xx & Qxx08xHx Series

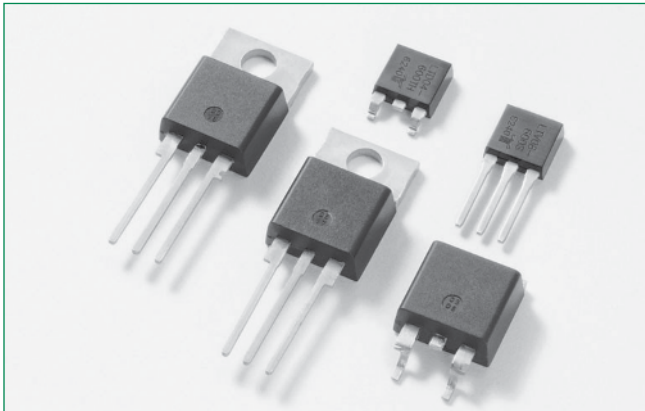

Description

This 8 Amp bidirectional solid state switch series is designed for AC switching and phase control applications such as motor speed and temperature modulation controls, lighting controls, and static switching relays.

Sensitive type components guarantee gate control in Quadrants I & IV as needed for digital control circuitry.

Standard type components normally operate in Quadrants I & III triggered from AC line.

Alternistor type components only operate in quadrants I, II, & III and are used in circuits requiring high dv/dt capability.

Agency Approval

Agency	Agency File Number
	E71639*

* - L Package Only

Main Features

Symbol	Value	Unit
$I_{T(RMS)}$	8	A
V_{DRM}/V_{RRM}	400, 600, 800 or 1000	V
$I_{GT (Q1)}$	5 to 50	mA

Features & Benefits

- RoHS-compliant
- Glass – passivated junctions
- Voltage capability up to 1000 V
- Surge capability up to 100 A
- The L-package has an isolation rating of 2500V_{RMS}
- Solid-state switching eliminates arcing or contact bounce that create voltage transients
- No contacts to wear out from reaction of switching events
- Restricted (or limited) RFI generation, depending on activation point of sine wave
- Requires a short gate activation pulse during each half-cycle

Schematic Symbol

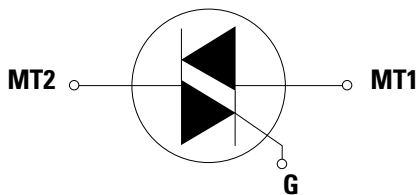

Applications

Excellent for AC switching and phase control applications such as heating, lighting, and motor speed controls.

Typical applications are AC solid-state switches, light dimmers, power tools, home/brown goods and white goods appliances.

Alternistor Triacs (no snubber required) are used in applications with extremely inductive loads requiring highest commutation performance.

Internally constructed isolated packages are offered for ease of heat sinking with highest isolation voltage.

Additional Information



Datasheet



Resources



Samples

Absolute Maximum Ratings — Sensitive Triac (4 Quadrants)

Symbol	Parameter		Value	Unit
$I_{T(RMS)}$	RMS on-state current (full sine wave)	Lxx08Ly Lxx08Ry / Lxx08Vy / Lxx08Dy	$T_c = 80^\circ\text{C}$ $T_c = 85^\circ\text{C}$	8 A
I_{TSM}	Non repetitive surge peak on-state current (full cycle, T_j initial = 25°C)	f = 50 Hz f = 60 Hz	t = 20 ms t = 16.7 ms	65 85 A
I^2t	I^2t Value for fusing	$t_p = 8.3$ ms		26.5 A^2s
di/dt	Critical rate of rise of on-state current $I_G = 50\text{mA}$ with $0.1\mu\text{s}$ rise time	f = 120 Hz	$T_j = 110^\circ\text{C}$	70 $\text{A}/\mu\text{s}$
I_{GTM}	Peak gate trigger current	$t_p = 20\mu\text{s}$	$T_j = 110^\circ\text{C}$	4 A
$P_{G(AV)}$	Average gate power dissipation		$T_j = 110^\circ\text{C}$	0.4 W
T_{stg}	Storage temperature range			-40 to 150 $^\circ\text{C}$
T_j	Operating junction temperature range			-40 to 110 $^\circ\text{C}$

Note: xx = voltage/10, y = sensitivity

Absolute Maximum Ratings — Standard Triac

Symbol	Parameter		Value	Unit
$I_{T(RMS)}$	RMS on-state current (full sine wave)	Qxx08Ry / Qxx08Ny Qxx08Ly	$T_c = 95^\circ\text{C}$ $T_c = 90^\circ\text{C}$	8 A
I_{TSM}	Non repetitive surge peak on-state current (full cycle, T_j initial = 25°C)	f = 50 Hz f = 60 Hz	t = 20 ms t = 16.7 ms	83 100 A
I^2t	I^2t Value for fusing	$t_p = 8.3$ ms		41 A^2s
di/dt	Critical rate of rise of on-state current $I_G = 200\text{mA}$ with $\leq 0.1\mu\text{s}$ rise time	f = 120 Hz	$T_j = 125^\circ\text{C}$	70 $\text{A}/\mu\text{s}$
I_{GTM}	Peak gate trigger current	$t_p = 20\mu\text{s}$	$T_j = 125^\circ\text{C}$	4 A
$P_{G(AV)}$	Average gate power dissipation	-	$T_j = 125^\circ\text{C}$	0.5 W
T_{stg}	Storage temperature range	-	-	-40 to 150 $^\circ\text{C}$
T_j	Operating junction temperature range	-	-	-40 to 125 $^\circ\text{C}$

Note: xx = voltage/10, y = sensitivity

Absolute Maximum Ratings — Alternistor (3 Quadrants)

Symbol	Parameter	Value	Unit																
$I_{T(RMS)}$	RMS on-state current (full sine wave)	Qxx08LHy Qxx08RH _y / Qxx08NH _y Qxx08VH _y / Qxx08DH _y $T_C = 90^\circ\text{C}$ $T_C = 95^\circ\text{C}$	8 A																
I_{TSM}	Non repetitive surge peak on-state current (full cycle, T_J initial = 25°C)	<table border="1"> <tr> <td>f = 50 Hz</td> <td>t = 20 ms</td> <td>Qxx08VH_y / Qxx08DH_y</td> <td>80</td> </tr> <tr> <td></td> <td></td> <td>Qxx08LH_y / Qxx08RH_y / Qxx08NH_y</td> <td>83</td> </tr> <tr> <td></td> <td></td> <td>Qxx08VH_y / Qxx08DH_y</td> <td>85</td> </tr> <tr> <td>f = 60 Hz</td> <td>t = 16.7 ms</td> <td>Qxx08LH_y / Qxx08RH_y / Qxx08NH_y</td> <td>100</td> </tr> </table>	f = 50 Hz	t = 20 ms	Qxx08VH _y / Qxx08DH _y	80			Qxx08LH _y / Qxx08RH _y / Qxx08NH _y	83			Qxx08VH _y / Qxx08DH _y	85	f = 60 Hz	t = 16.7 ms	Qxx08LH _y / Qxx08RH _y / Qxx08NH _y	100	A
f = 50 Hz	t = 20 ms	Qxx08VH _y / Qxx08DH _y	80																
		Qxx08LH _y / Qxx08RH _y / Qxx08NH _y	83																
		Qxx08VH _y / Qxx08DH _y	85																
f = 60 Hz	t = 16.7 ms	Qxx08LH _y / Qxx08RH _y / Qxx08NH _y	100																
I^2t	I^2t Value for fusing	$t_p = 8.3$ ms	<table border="1"> <tr> <td>Qxx08VH_y / Qxx08DH_y</td> <td>30</td> </tr> <tr> <td>Qxx08LH_y / Qxx08RH_y / Qxx08NH_y</td> <td>41</td> </tr> </table>	Qxx08VH _y / Qxx08DH _y	30	Qxx08LH _y / Qxx08RH _y / Qxx08NH _y	41	A ² s											
Qxx08VH _y / Qxx08DH _y	30																		
Qxx08LH _y / Qxx08RH _y / Qxx08NH _y	41																		
di/dt	Critical rate of rise of on-state current	f = 120 Hz	$T_J = 125^\circ\text{C}$	70 A/μs															
I_{GTM}	Peak gate trigger current	$t_p = 20\mu\text{s}$	$T_J = 125^\circ\text{C}$	<table border="1"> <tr> <td>Qxx08VH_y / Qxx08DH_y</td> <td>4</td> </tr> <tr> <td>Qxx08LH_y / Qxx08RH_y / Qxx08NH_y</td> <td>4</td> </tr> </table>	Qxx08VH _y / Qxx08DH _y	4	Qxx08LH _y / Qxx08RH _y / Qxx08NH _y	4	A										
Qxx08VH _y / Qxx08DH _y	4																		
Qxx08LH _y / Qxx08RH _y / Qxx08NH _y	4																		
$P_{G(AV)}$	Average gate power dissipation	$T_J = 125^\circ\text{C}$	$I_{GT} = 10\text{mA}$ $I_{GT} = 35\text{mA}$	<table border="1"> <tr> <td>Qxx08VH_y / Qxx08DH_y</td> <td>0.4</td> </tr> <tr> <td>Qxx08LH_y / Qxx08RH_y / Qxx08NH_y</td> <td>0.5</td> </tr> </table>	Qxx08VH _y / Qxx08DH _y	0.4	Qxx08LH _y / Qxx08RH _y / Qxx08NH _y	0.5	W										
Qxx08VH _y / Qxx08DH _y	0.4																		
Qxx08LH _y / Qxx08RH _y / Qxx08NH _y	0.5																		
T_{stg}	Storage temperature range		-	-40 to 150 °C															
T_J	Operating junction temperature range		-	-40 to 125 °C															

Note: xx = voltage/10, y = sensitivity

Electrical Characteristics ($T_J = 25^\circ\text{C}$, unless otherwise specified) — Sensitive Triac (4 Quadrants)

Symbol	Test Conditions	Quadrant	Lxx08x6	Lxx08x8	Unit
I_{GT}	$V_D = 12\text{V}$ $R_L = 60\ \Omega$	I – II – III IV	5 10	10 20	mA
V_{GT}	$V_D = 12\text{V}$ $R_L = 60\ \Omega$	ALL		1.3	V
V_{GD}	$V_D = V_{DRM}$ $R_L = 3.3\ \text{k}\Omega$ $T_J = 110^\circ\text{C}$	ALL		0.2	V
I_H	$I_T = 100\text{mA}$		10	20	mA
dv/dt	$V_D = V_{DRM}$ Gate Open $T_J = 100^\circ\text{C}$	400V 600V	30 20	40 30	V/μs
(dv/dt) _c	(di/dt) _c = 4.3 A/ms $T_J = 110^\circ\text{C}$		2	2	V/μs
t_{gt}	$I_G = 100\text{mA}$ $PW = 15\mu\text{s}$ $I_T = 11.3\ \text{A(pk)}$		3.0	3.2	μs

Note: xx = voltage/10, x = package, y = sensitivity

Electrical Characteristics ($T_J = 25^\circ\text{C}$, unless otherwise specified) — Standard Triac

Symbol	Test Conditions	Quadrant		Qxx08x4	Qxx08x5	Unit
I_{GT}	$V_D = 12V$ $R_L = 60\ \Omega$	I – II – III IV	MAX. TYP.	25 50	50 75	mA
V_{GT}	$V_D = 12V$ $R_L = 60\ \Omega$	I – II – III	MAX.	1.3		V
V_{GD}	$V_D = V_{DRM}$ $R_L = 3.3\ \text{k}\Omega$ $T_J = 125^\circ\text{C}$	ALL	MIN.	0.2		V
I_H	$I_T = 200\text{mA}$		MAX.	50	50	mA
dv/dt	$V_D = V_{DRM}$ Gate Open $T_J = 125^\circ\text{C}$	400V 600V 800V 1000V	MIN.	150 - - -	- 125 100 80	V/ μs
(dv/dt)c	(di/dt)c = 4.3 A/ms $T_J = 125^\circ\text{C}$		TYP.	4	4	V/ μs
t_{gt}	$I_G = 100\text{mA}$ $PW = 15\ \mu\text{s}$ $I_T = 11.3\ \text{A(pk)}$		TYP.	3.0	3.0	μs

Electrical Characteristics ($T_J = 25^\circ\text{C}$, unless otherwise specified) — Alternistor Triac (3 Quadrants)

Symbol	Test Conditions	Quadrant		Qxx08xH3	Qxx08xH4	Unit	
I_{GT}	$V_D = 12V$ $R_L = 60\ \Omega$	I – II – III	MAX.	10	35	mA	
V_{GT}	$V_D = 12V$ $R_L = 60\ \Omega$	I – II – III	MAX.	-	1.3	V	
V_{GD}	$V_D = V_{DRM}$ $R_L = 3.3\ \text{k}\Omega$ $T_J = 125^\circ\text{C}$	I – II – III	MIN.	-	0.2	V	
I_H	$I_T = 100\text{mA}$		MAX.	-	15	35	mA
dv/dt	$V_D = V_{DRM}$ Gate Open $T_J = 125^\circ\text{C}$	Qxx08LHy / Qxx08RHx / Qxx08NHx Qxx08VHy / Qxx08DHx	MIN.	400V 600V 800V 1000V 400V 600V 800V 1000V	75 50 75 50 50	400 300 200 100 450 350 250 150	V/ μs
(dv/dt)c	(di/dt)c = 4.3 A/ms $T_J = 125^\circ\text{C}$		MIN.	-	20	25	V/ μs
t_{gt}	$I_G = 100\text{mA}$ $PW = 15\ \mu\text{s}$ $I_T = 11.3\ \text{A(pk)}$		TYP.	-	4.0	4.0	μs

Note: xx = voltage/10, x = package, y = sensitivity

Static Characteristics

Symbol	Test Conditions				Value	Unit	
V_{TM}	$I_{TM} = 11.3A$ $t_p = 380 \mu s$				MAX.	1.60	V
I_{DRM} I_{RRM}	$V_{DRM} = V_{RRM}$	Lxx08xy	$T_J = 25^\circ C$	400 - 600V	MAX.	10	μA
			$T_J = 110^\circ C$	400 - 600V		0.5	mA
			$T_J = 25^\circ C$	400 - 1000V		20	μA
			$T_J = 125^\circ C$	400 - 800V		2	mA
		Qxx08xy	$T_J = 100^\circ C$	1000V		3	mA
			$T_J = 25^\circ C$	400 - 800V		10	μA
			$T_J = 125^\circ C$	1000V		20	μA
			$T_J = 100^\circ C$	400 - 800V		2	mA
Qxx08xHy	$T_J = 100^\circ C$	1000V	3	mA			

Thermal Resistances

Symbol	Parameter	Value	Unit
$R_{\theta(J-C)}$	Junction to case (AC)	L/Qxx08Ryy / L/Qxx08Nyy	1.5
		L/Qxx08Lyy	2.8
		L/Qxx08Vyy	2.1
		L/Qxx08Ryy	45
$R_{\theta(J-A)}$	Junction to ambient	L/Qxx08Lyy	50
		L/Qxx08Vyy	64

Note: xx = voltage/10, x = package, y = sensitivity, yy = type & sensitivity

Figure 1: Definition of Quadrants

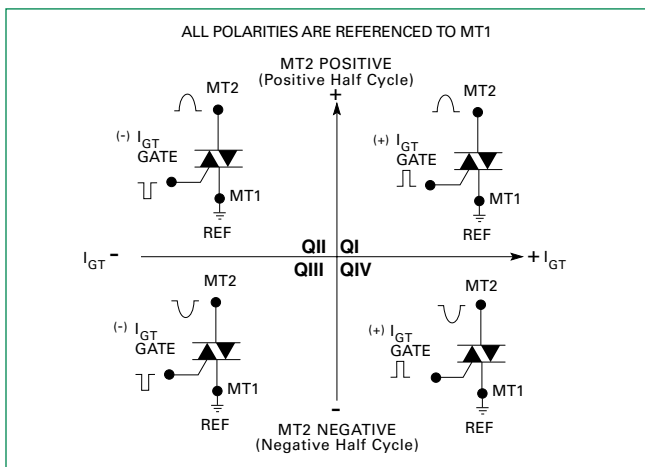

Note: Alternistors will not operate in QIV

Figure 2: Normalized DC Gate Trigger Current for All Quadrants vs. Junction Temperature

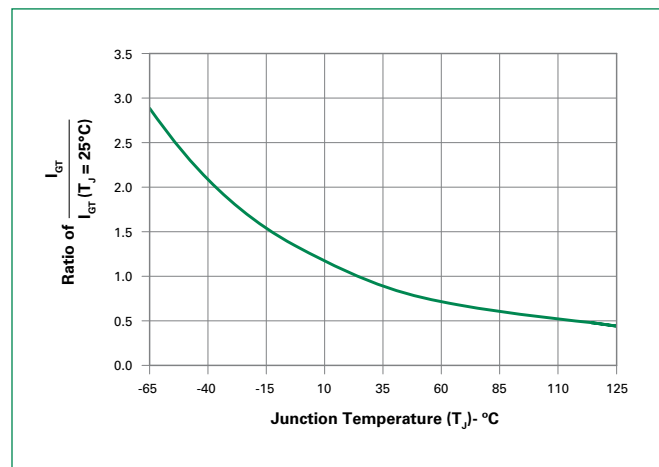

Figure 3: Normalized DC Holding Current vs. Junction Temperature

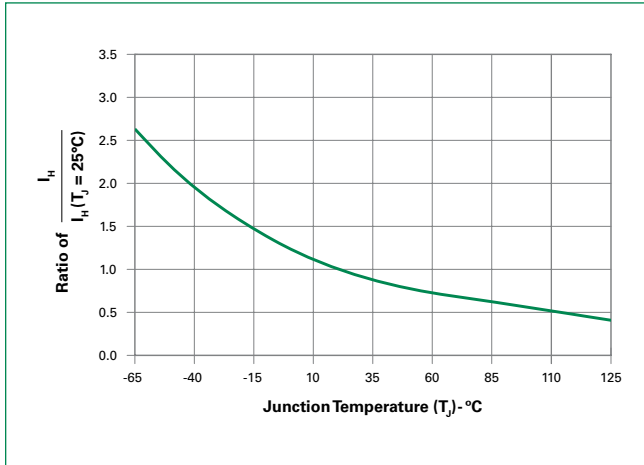

Figure 4: Normalized DC Gate Trigger Voltage for All Quadrants vs. Junction Temperature

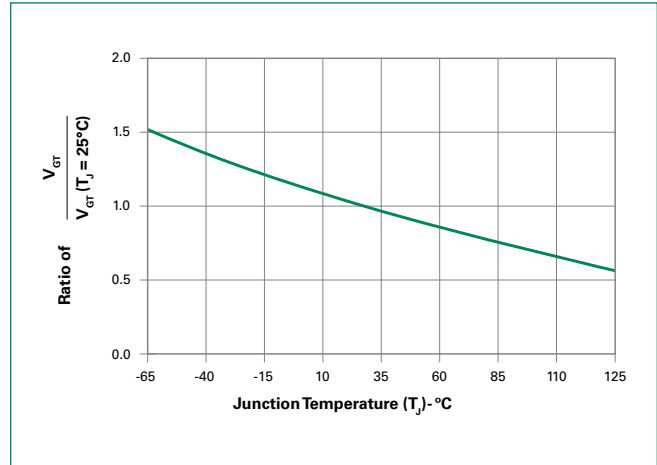

Figure 5: Power Dissipation (Typical) vs. RMS On-State Current

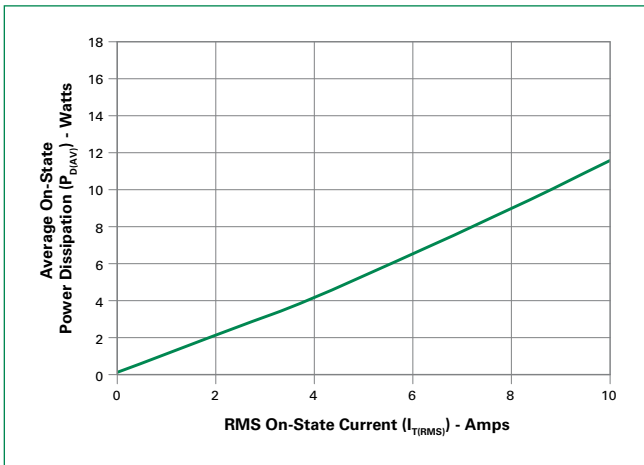

Figure 6: Maximum Allowable Case Temperature vs. On-State Current (Sensitive Triac)

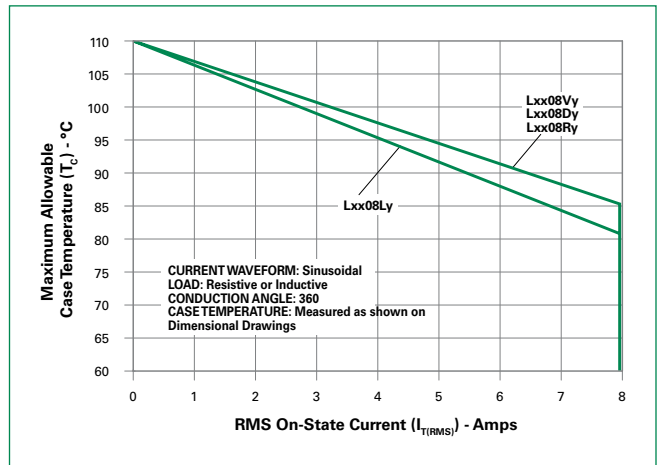

Figure 7: Maximum Allowable Case Temperature vs. On-State Current (Standard / Alternistor Triac)

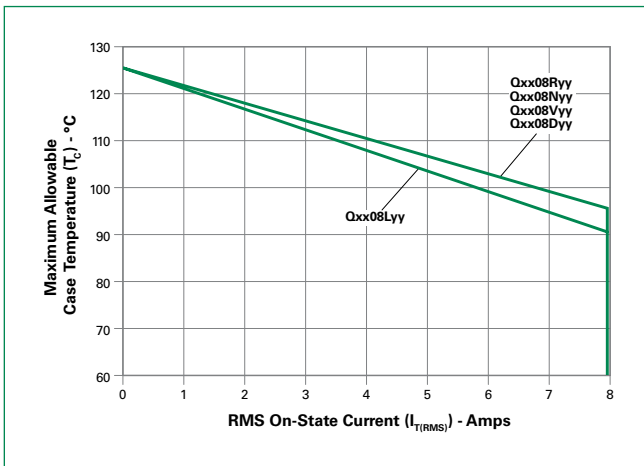
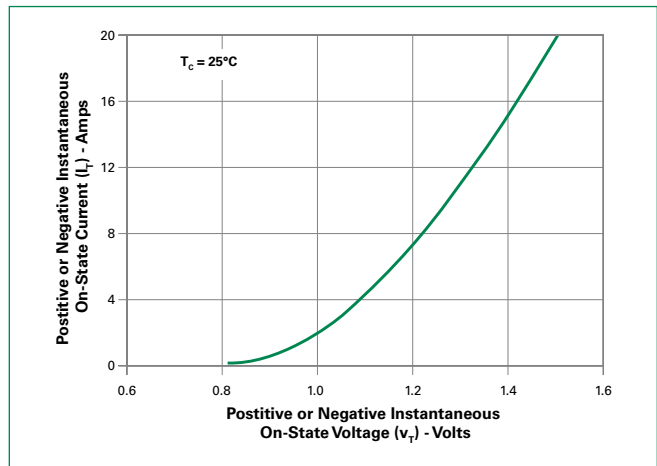

Figure 8: On-State Current vs. On-State Voltage (Typical)



Note: xx = voltage/10, x = package, yy = type & sensitivity

Figure 9: Maximum Allowable Ambient Temperature vs. On-State Current

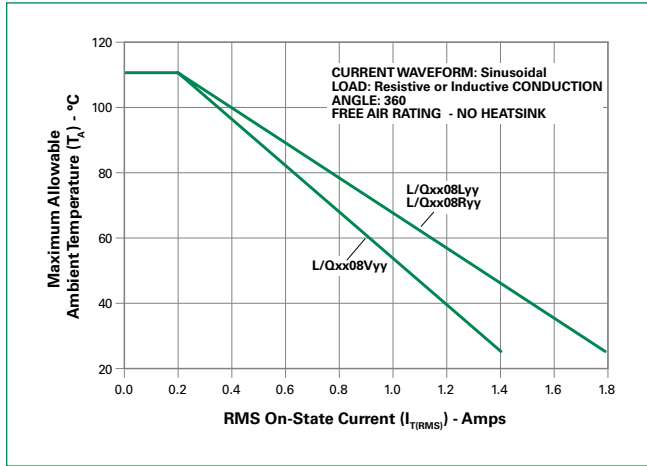
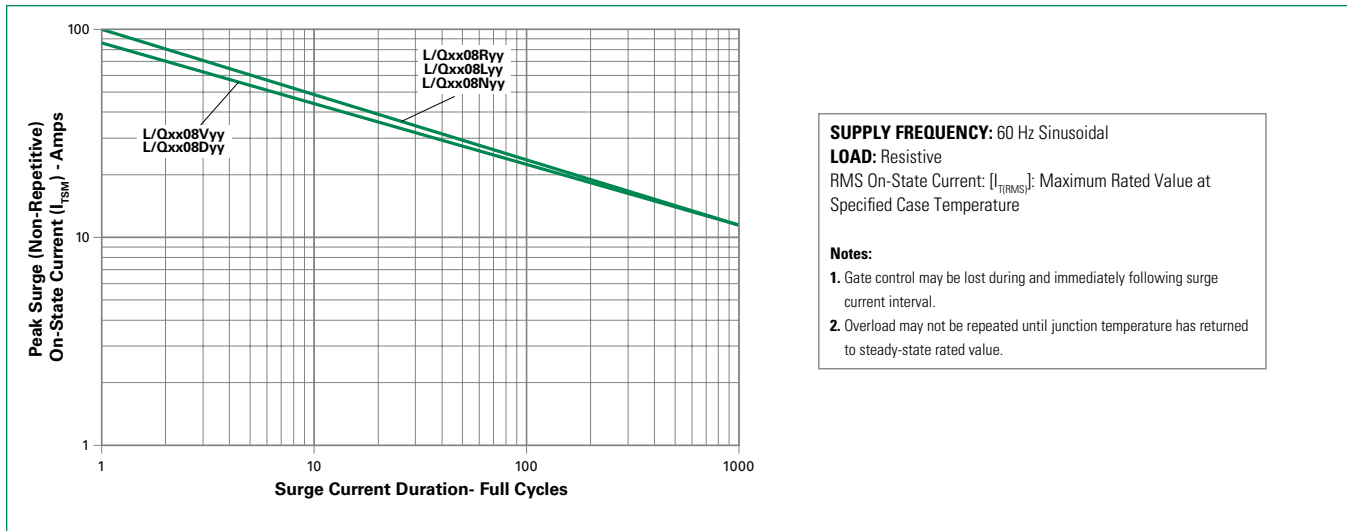

Figure 10: Surge Peak On-State Current vs. Number of Cycles



Note: xx = voltage/10, x = package, y = sensitivity, yy = type & sensitivity

Soldering Parameters

Reflow Condition		Pb – Free assembly
Pre Heat	- Temperature Min ($T_{s(min)}$)	150°C
	- Temperature Max ($T_{s(max)}$)	200°C
	- Time (min to max) (t_s)	60 – 180 secs
Average ramp up rate (Liquidus Temp) (T_L) to peak		5°C/second max
$T_{s(max)}$ to T_L - Ramp-up Rate		5°C/second max
Reflow	- Temperature (T_L) (Liquidus)	217°C
	- Temperature (t_L)	60 – 150 seconds
Peak Temperature (T_p)		260 ^{+0/-5} °C
Time within 5°C of actual peak Temperature (t_p)		20 – 40 seconds
Ramp-down Rate		5°C/second max
Time 25°C to peak Temperature (T_p)		8 minutes Max.
Do not exceed		280°C

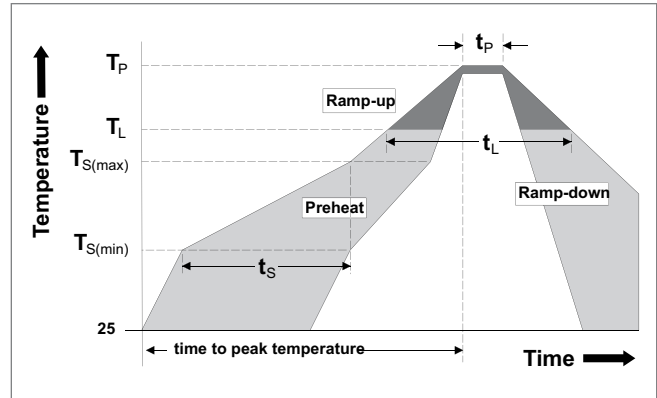

Physical Specifications

Terminal Finish	100% Matte Tin-plated
Body Material	UL Recognized compound meeting flammability rating V-0
Terminal Material	Copper Alloy

Design Considerations

Careful selection of the correct component for the application's operating parameters and environment will go a long way toward extending the operating life of the Thyristor. Good design practice should limit the maximum continuous current through the main terminals to 75% of the component rating. Other ways to ensure long life for a power discrete semiconductor are proper heat sinking and selection of voltage ratings for worst case conditions. Overheating, overvoltage (including dv/dt), and surge currents are the main killers of semiconductors. Correct mounting, soldering, and forming of the leads also help protect against component damage.

Environmental Specifications

Test	Specifications and Conditions
AC Blocking (V_{DRM})	MIL-STD-750, M-1040, Cond A Applied Peak AC voltage @ 125°C for 1008 hours
Temperature Cycling	MIL-STD-750, M-1051, 100 cycles; -40°C to +150°C; 15-min dwell-time
Temperature/Humidity	EIA / JEDEC, JESD22-A101 1008 hours; 320V - DC: 85°C; 85% rel humidity
High Temp Storage	MIL-STD-750, M-1031, 1008 hours; 150°C
Low-Temp Storage	1008 hours; -40°C
Resistance to Solder Heat	MIL-STD-750 Method 2031
Solderability	ANSI/J-STD-002, category 3, Test A
Lead Bend	MIL-STD-750, M-2036 Cond E

Dimensions — TO-220AB (R-Package) — Non-Isolated Mounting Tab Common with Center Lead

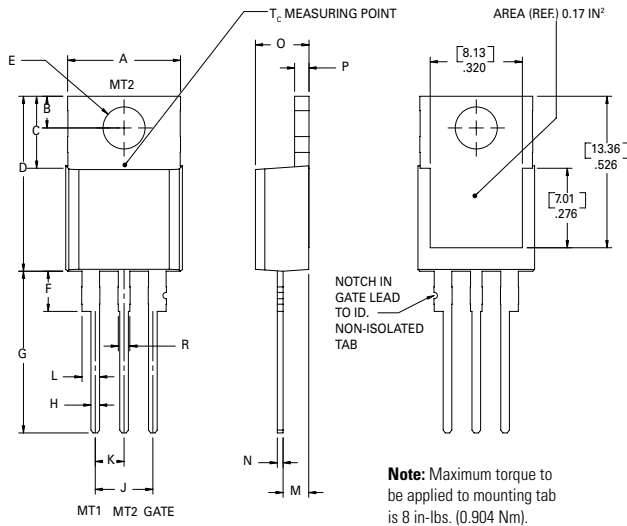

Dimension	Inches		Millimeters	
	Min	Max	Min	Max
A	0.380	0.420	9.65	10.67
B	0.105	0.115	2.67	2.92
C	0.230	0.250	5.84	6.35
D	0.590	0.620	14.99	15.75
E	0.142	0.147	3.61	3.73
F	0.110	0.130	2.79	3.30
G	0.540	0.575	13.72	14.61
H	0.025	0.035	0.64	0.89
J	0.195	0.205	4.95	5.21
K	0.095	0.105	2.41	2.67
L	0.060	0.075	1.52	1.91
M	0.085	0.095	2.16	2.41
N	0.018	0.024	0.46	0.61
O	0.178	0.188	4.52	4.78
P	0.045	0.060	1.14	1.52
R	0.038	0.048	0.97	1.22

Dimensions — TO-220AB (L-Package) — Isolated Mounting Tab

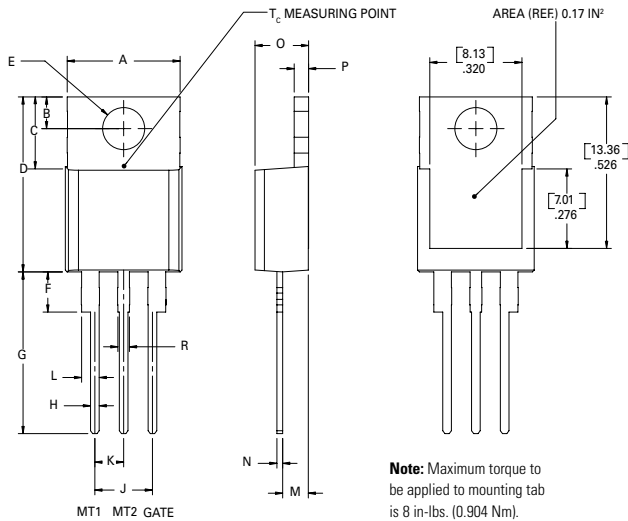

Dimension	Inches		Millimeters	
	Min	Max	Min	Max
A	0.380	0.420	9.65	10.67
B	0.105	0.115	2.67	2.92
C	0.230	0.250	5.84	6.35
D	0.590	0.620	14.99	15.75
E	0.142	0.147	3.61	3.73
F	0.110	0.130	2.79	3.30
G	0.540	0.575	13.72	14.61
H	0.025	0.035	0.64	0.89
J	0.195	0.205	4.95	5.21
K	0.095	0.105	2.41	2.67
L	0.060	0.075	1.52	1.91
M	0.085	0.095	2.16	2.41
N	0.018	0.024	0.46	0.61
O	0.178	0.188	4.52	4.78
P	0.045	0.060	1.14	1.52
R	0.038	0.048	0.97	1.22

Dimensions — TO-263AB (N-Package) — D²-PAK Surface Mount

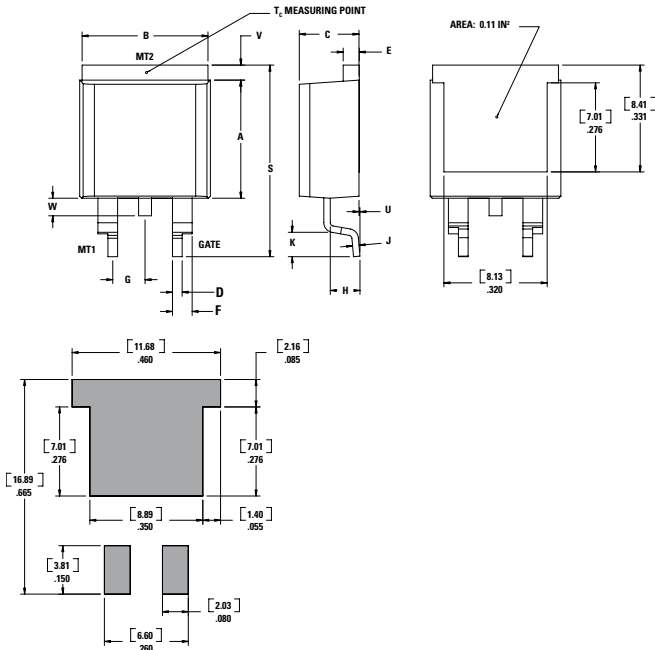

Dimension	Inches		Millimeters	
	Min	Max	Min	Max
A	0.360	0.370	9.14	9.40
B	0.380	0.420	9.65	10.67
C	0.178	0.188	4.52	4.78
D	0.025	0.035	0.64	0.89
E	0.045	0.060	1.14	1.52
F	0.060	0.075	1.52	1.91
G	0.095	0.105	2.41	2.67
H	0.092	0.102	2.34	2.59
J	0.018	0.024	0.46	0.61
K	0.090	0.110	2.29	2.79
S	0.590	0.625	14.99	15.88
V	0.035	0.045	0.89	1.14
U	0.002	0.010	0.05	0.25
W	0.040	0.070	1.02	1.78

Dimensions — TO-251AA (V-Package) — V-PAK Through Hole

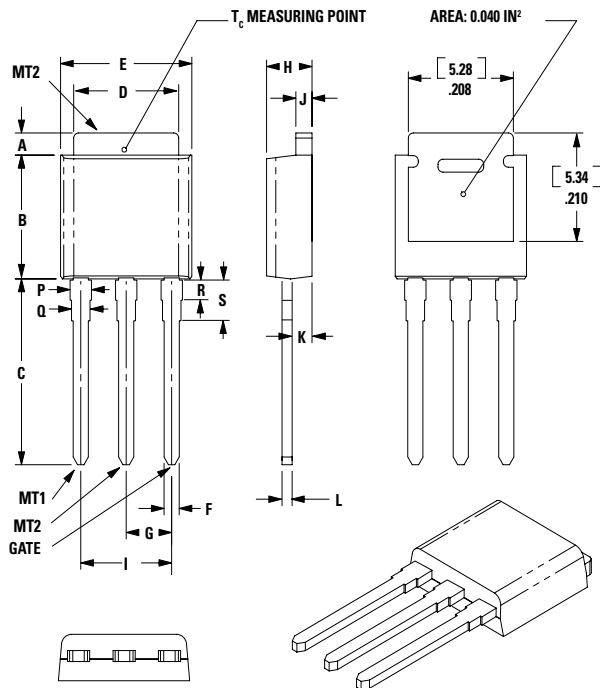

Dimension	Inches			Millimeters		
	Min	Typ	Max	Min	Typ	Max
A	0.037	0.040	0.043	0.94	1.01	1.09
B	0.235	0.242	0.245	5.97	6.15	6.22
C	0.350	0.361	0.375	8.89	9.18	9.53
D	0.205	0.208	0.213	5.21	5.29	5.41
E	0.255	0.262	0.265	6.48	6.66	6.73
F	0.027	0.031	0.033	0.69	0.80	0.84
G	0.087	0.090	0.093	2.21	2.28	2.36
H	0.085	0.092	0.095	2.16	2.34	2.41
I	0.176	0.180	0.184	4.47	4.57	4.67
J	0.018	0.020	0.023	0.46	0.51	0.58
K	0.035	0.037	0.039	0.90	0.95	1.00
L	0.018	0.020	0.023	0.46	0.52	0.58
P	0.042	0.047	0.052	1.06	1.20	1.32
Q	0.034	0.039	0.044	0.86	1.00	1.11
R	0.034	0.039	0.044	0.86	1.00	1.11
S	0.074	0.079	0.084	1.86	2.00	2.11

Dimensions — TO-252AA (D-Package) — D-PAK Surface Mount

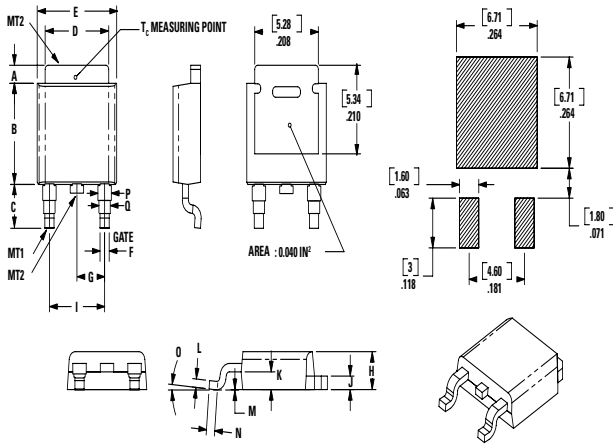

Dimension	Inches			Millimeters		
	Min	Typ	Max	Min	Typ	Max
A	0.037	0.040	0.043	0.94	1.01	1.09
B	0.235	0.243	0.245	5.97	6.16	6.22
C	0.106	0.108	0.113	2.69	2.74	2.87
D	0.205	0.208	0.213	5.21	5.29	5.41
E	0.255	0.262	0.265	6.48	6.65	6.73
F	0.027	0.031	0.033	0.69	0.80	0.84
G	0.087	0.090	0.093	2.21	2.28	2.36
H	0.085	0.092	0.095	2.16	2.33	2.41
I	0.176	0.179	0.184	4.47	4.55	4.67
J	0.018	0.020	0.023	0.46	0.51	0.58
K	0.035	0.037	0.039	0.90	0.95	1.00
L	0.018	0.020	0.023	0.46	0.51	0.58
M	0.000	0.000	0.004	0.00	0.00	0.10
N	0.021	0.026	0.027	0.53	0.67	0.69
O	0°	0°	5°	0°	0°	5°
P	0.042	0.047	0.052	1.06	1.20	1.32
Q	0.034	0.039	0.044	0.86	1.00	1.11

Product Selector

Part Number	Voltage (xx)				Gate Sensitivity Quadrants		Type	Package
	400V	600V	800V	1000V	I – II – III	IV		
Lxx08L6	X	X	-	-	5 mA	10 mA	Sensitive Triac	TO-220L
Lxx08D6	X	X	-	-	5 mA	10 mA	Sensitive Triac	TO-252 D-PAK
Lxx08R6	X	X	-	-	5mA	10mA	Sensitive Triac	TO-220R
Lxx08V6	X	X	-	-	5 mA	10 mA	Sensitive Triac	TO-251 V-PAK
Lxx08L8	X	X	-	-	10 mA	20 mA	Sensitive Triac	TO-220L
Lxx08D8	X	X	-	-	10 mA	20 mA	Sensitive Triac	TO-252 D-PAK
Lxx08R8	X	X	-	-	10mA	20mA	Sensitive Triac	TO-220R
Lxx08V8	X	X	-	-	10 mA	20 mA	Sensitive Triac	TO-251 V-PAK
Qxx08NH3	X	X	-	-	10mA	-	Alternistor Triac	TO-263 D ² -PAK
Qxx08RH3	X	X	-	-	10 mA	-	Alternistor Triac	TO-220R
Qxx08VH3	X	X	-	-	10 mA	-	Alternistor Triac	TO-251 V-PAK
Qxx08DH3	X	X	-	-	10 mA	-	Alternistor Triac	TO-252 D-PAK
Qxx08L4	X	-	-	-	25 mA	-	Triac	TO-220L
Qxx08R4	X	-	-	-	25 mA	-	Triac	TO-220R
Qxx08N4	X	-	-	-	25 mA	-	Triac	TO-263 D ² -PAK
Qxx08LH4	X	X	X	X	35 mA	-	Alternistor Triac	TO-220L
Qxx08RH4	X	X	X	X	35 mA	-	Alternistor Triac	TO-220R
Qxx08VH4	X	X	X	X	35 mA	-	Alternistor Triac	TO-251 V-PAK
Qxx08DH4	X	X	X	X	35 mA	-	Alternistor Triac	TO-252 D-PAK
Qxx08NH4	X	X	X	X	35 mA	-	Alternistor Triac	TO-263 D ² -PAK
Qxx08L5	-	X	X	X	50 mA	-	Triac	TO-220L
Qxx08R5	-	X	X	X	50 mA	-	Triac	TO-220R
Qxx08N5	-	X	X	X	50 mA	-	Triac	TO-263 D ² -PAK

Packing Options

Part Number	Marking	Weight	Packing Mode	Base Quantity
L/Qxx08L/RyyTP	L/Qxx08L/Ryy	2.2 g	Tube Pack	1000 (50 per tube)
Qxx08NyyTP	Qxx08Nyy	1.6 g	Tube	1000 (50 per tube)
Qxx08NyyRP	Qxx08Nyy	1.6 g	Embossed Carrier	500
L/Qxx08DyyTP	L/Qxx08Dyy	0.3 g	Tube	750 (75 per tube)
L/Qxx08DyyRP	L/Qxx08Dyy	0.3 g	Embossed Carrier	2500
L/Qxx08VyyTP	L/Qxx08Vyy	0.4 g	Tube	750 (75 per tube)

Note: xx = voltage, x = package, y = sensitivity, yy = type & sensitivity

TO-252 Embossed Carrier Reel Pack (RP) Specifications

Meets all EIA-481-2 Standards

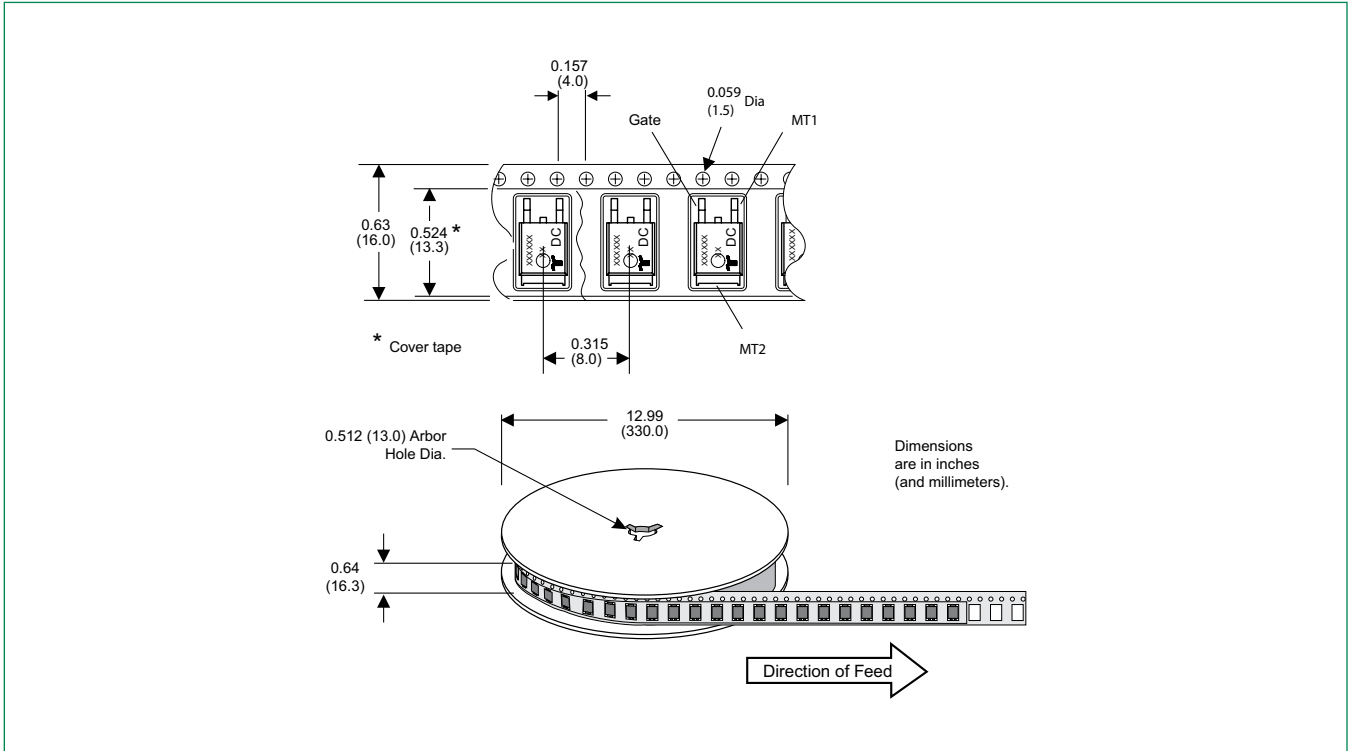

TO-263 Embossed Carrier Reel Pack (RP) Specifications

Meets all EIA-481-2 Standards

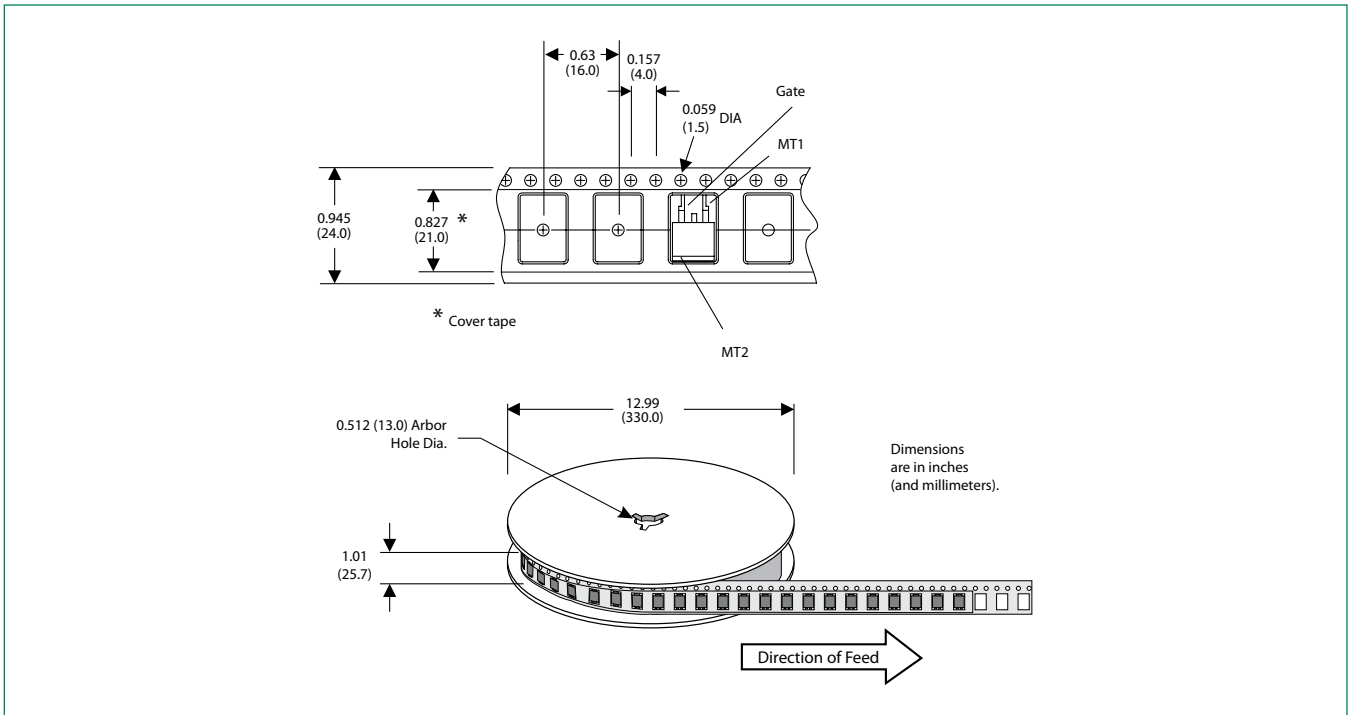

Part Numbering System

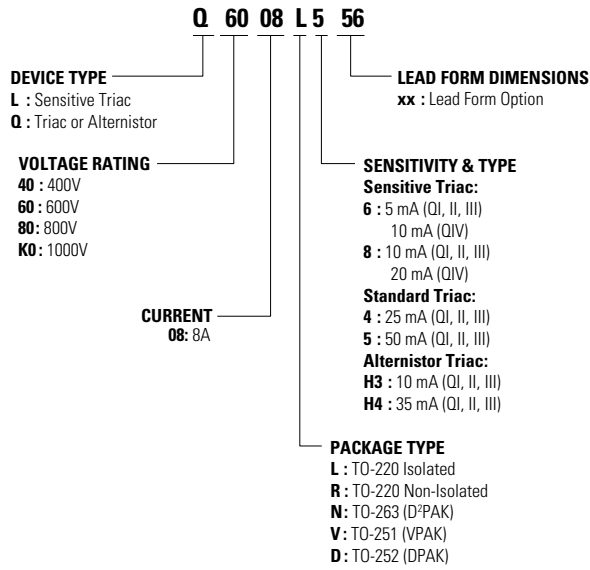

Part Marking System

TO-251AA – (V Package)
TO-252AA – (D Package)

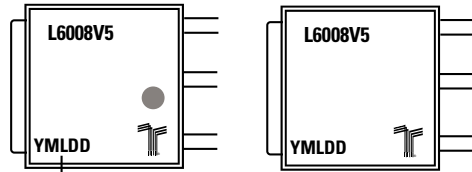

Date Code Marking
Y: Year Code
M: Month Code
L: Location Code
DD: Calendar Code

TO-220 AB – (L and R Package)
TO-263 AB – (N Package)

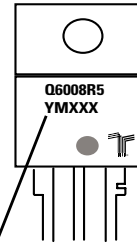

Date Code Marking
Y: Year Code
M: Month Code
XXX: Lot Trace Code