

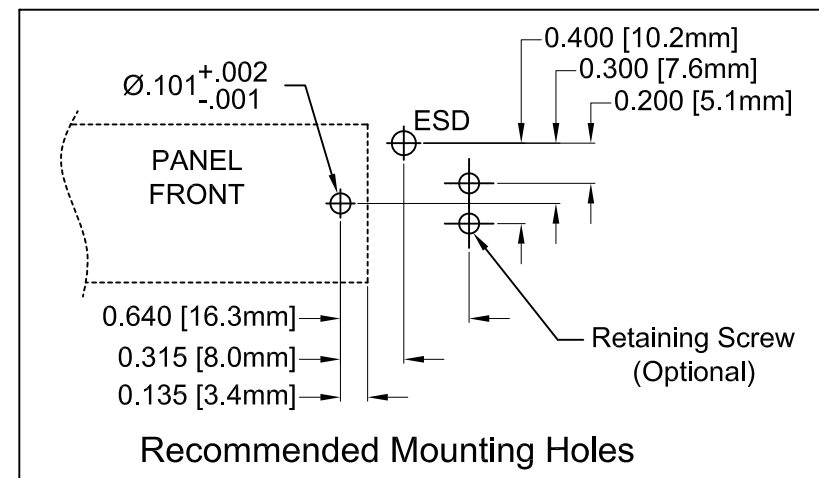

REV.	DESCRIPTION	DATE	APPROVED
A	Engineering Release.	06/26/14	J. C.

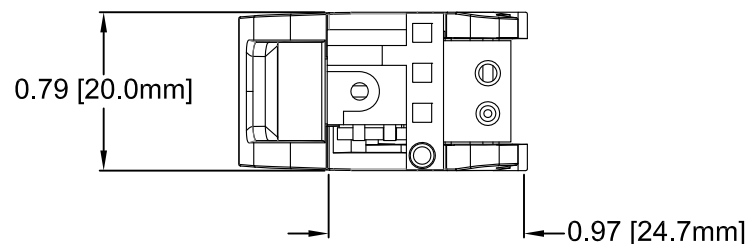
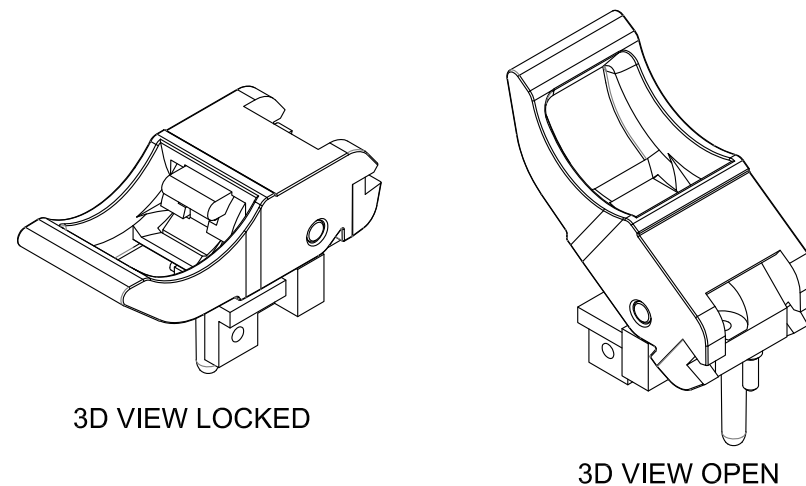
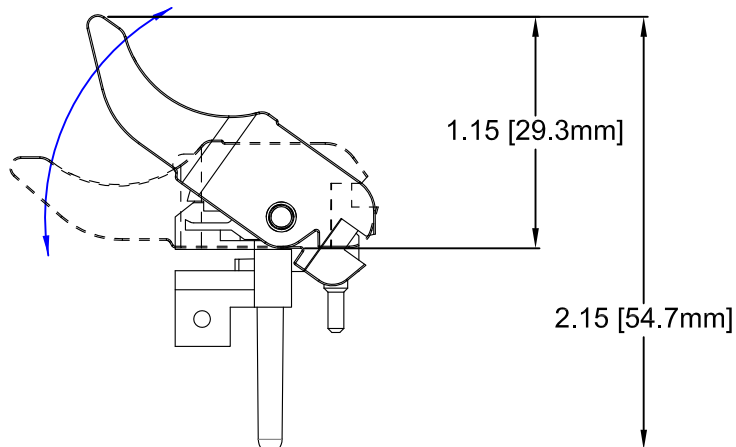

**NOTES:**

1. Compliant with PICMG CPCI standard
2. Mounting screws shipped unassembled

STANDARD TOLERANCE ( UNLESS OTHERWISE SPECIFIED )		 <b>BIVAR</b> <sup>®</sup> 4 THOMAS, IRVINE, CA. 92618 TEL: (949) 951-8808 FAX: (949) 951-3974					
DECIMALS	ANGULAR						
.X ±.1	X° ± 1°		<b>TITLE: CPCI EJECTOR HANDLE BOTTOM, STYLE E5</b>				
.XX ±.01				DESIGNED: <b>Brian Oliver</b>	DATE: <b>06/26/14</b>	<b>PART NO: CPCI-E5-B</b>	REVISION: <b>A</b>
.XXX ±.005				CHECKED: <b>A. Wright</b>	DATE: <b>06/26/14</b>	<b>CAGE CODE : 32559</b>	<b>SHEET # 1 OF 1</b>
				CAD GENERATED DOCUMENT, DO NOT MEASURE DRAWING.			