

100-W STEREO DIGITAL AMPLIFIER POWER STAGE CONTROLLER

FEATURES

- Stereo H-Bridge Controller
- Efficiency > 95%[†]
- 2x100 W (RMS) at 6 Ω (BTL)[†]
- THD+N < 0.15% (Typical at 100 W at 6 Ω, 1 kHz)[‡]
- Half-Bridge Independent Control
- Glueless Interface to TAS50XX Digital Audio PWM Processors
- 3.3-V Digital Interface
- Fault Detection
 - Overcurrent
 - Overtemperature
 - Undervoltage Protection for External MOSFETs
- Low Profile 56-Terminal TSSOP SMD Package

- Power Amplifiers
- Home Theater
- Subwoofer Driver

DESCRIPTION

The TAS5182 device is a high-performance, stereo digital amplifier power stage controller. It is designed to drive two discrete bridge-tied-load (BTL) MOSFET output stages at up to 100 W per channel at 6 Ω. The TAS5182 device, incorporating Texas Instrument's PurePath™ technology, is used in conjunction with a digital audio PWM processor (TAS50XX) and two discrete MOSFET H-bridges (4 MOSFETs per H-Bridge) to deliver high-power, true digital audio amplification. The efficiency of this digital amplifier can be greater than 95%, reducing the size of both the power supplies and heat sinks needed. The TAS5182 device accepts a stereo PWM 3.3-V input, and it controls the switching of the discrete H-bridges.

Overcurrent, overtemperature, and undervoltage protections are built into the TAS5182 device, safeguarding the H-bridge and speakers against output short-circuit conditions, overtemperature conditions, and other fault conditions that could damage the system.

APPLICATIONS

- AV Receivers
- High Power DVD Receivers

Typical Stereo Audio System Using TAS5182 H-Bridge Driver

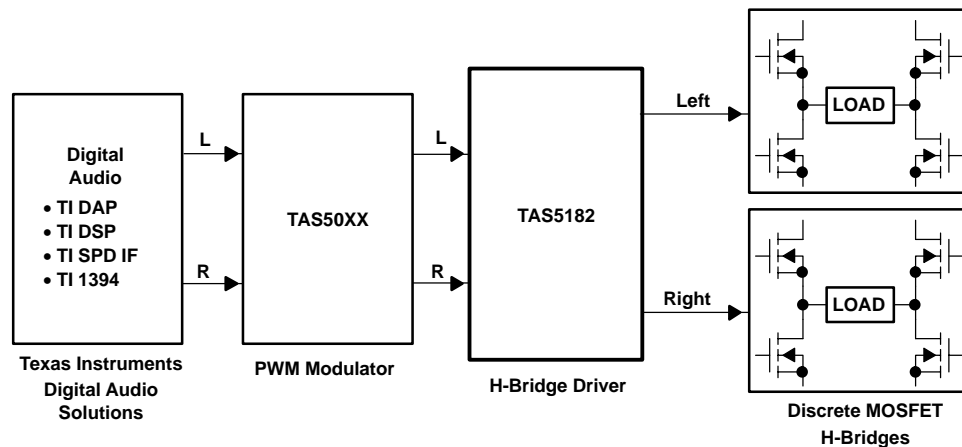

[†] When using appropriate MOSFETs.

[‡] When using recommended design.



Please be aware that an important notice concerning availability, standard warranty, and use in critical applications of Texas Instruments semiconductor products and disclaimers thereto appears at the end of this data sheet.

PurePath and PowerPAD are trademarks of Texas Instruments.

TAS5182

SLES045E - JUNE 2002 - REVISED MAY 2004

ORDERING INFORMATION

T _A	PACKAGE
0°C to 70°C	TAS5182DCA
-40°C to 85°C	TAS5182IDCA



These devices have limited built-in ESD protection. The leads should be shorted together or the device placed in conductive foam during storage or handling to prevent electrostatic damage to the MOS gates.

ABSOLUTE MAXIMUM RATINGS

over operating free-air temperature range (T_A) unless otherwise noted⁽¹⁾

		TAS5182
Supply voltage range	GV _{DD} to GV _{SS}	-0.3 V to 15 V
	DV _{DD} to DV _{SS}	-0.3 V to 3.6 V
AP, AM, BP, BM, CP, CM, DP, DM		-0.3 V to DV _{DD} + 0.3 V
RESET, SHUTDOWN		-0.3 V to DV _{DD} + 0.3 V
BST_A, BST_B, BST_C, BST_D to GV _{SS} for pulse width <100 ns		63 V
Switching frequency		1500 kHz
Operating junction temperature range, T _J		150°C
Storage temperature range, T _{stg}		-65°C to 150°C

⁽¹⁾ Stresses beyond those listed under “absolute maximum ratings” may cause permanent damage to the device. These are stress ratings only, and functional operation of the device at these or any other conditions beyond those indicated under “recommended operating conditions” is not implied. Exposure to absolute-maximum-rated conditions for extended periods may affect device reliability.

RECOMMENDED OPERATING CONDITIONS

		MIN	NOM	MAX	UNIT
Supply voltage range	GV _{DD} to GV _{SS}	9	12	12.6	V
	DV _{DD} to DV _{SS}	3	3.3	3.6	V
High-side bootstrap supply voltage range	BST_A, BST_B, BST_C, BST_D		50	52.6	V
High-side drain connection voltage range	DHS_A, DHS_B, DHS_C, DHS_D		40	42	V
High-side source connection voltage range	SHS_A, SHS_B, SHS_C, SHS_D		40	42	V

ELECTRICAL CHARACTERISTICS

T_C = 25°C, DV_{DD} = 3.3 V, GV_{DD} = 12 V, Frequency = 384 kHz

PARAMETER	TEST CONDITIONS	MIN	TYP	MAX	UNIT
INPUT TERMINALS: AM, AP, BM, BP, CM, CP, DM, DP					
V _{IH}	High input voltage	2			V
V _{IL}	Low input voltage			0.8	V
R _I	Input resistance		50		kΩ
R _{dtp}	Dead time resistor range	0		100	kΩ
INPUT TERMINAL: RESET_X					
V _{IH(RESET)}	High input voltage	2			V
V _{IL(RESET)}	Low input voltage			0.8	V
GATE DRIVE OUTPUT: GHS_A, GHS_B, GHS_C, GHS_D, GLS_A, GLS_B, GLS_C, GLS_D					
I _{oso}	Source current, peak	V _O = 2 V	-1.2		A
I _{osi}	Sink current, peak	V _O = 8 V	1.6		A
BST DIODE					
V _d	Forward current voltage drop	I _d = 100 mA	2		V
SUPPLY CURRENTS					
I _{DVDD}	Operating supply current	No load on gate drive output	3		mA
I _{DVDDQ}	Quiescent supply current	No switching	3		mA
I _{GVDD}	Operating supply current	No load on gate drive output	15		mA
I _{GVDDQ}	Quiescent supply current	No switching	2		mA
VOLTAGE PROTECTION					
V _{uvp,G}	Undervoltage protection limit, GV _{DD}			8.3	V

SWITCHING CHARACTERISTICS

T_C = 25°C, DV_{DD} = 3.3 V, GV_{DD} = 12 V

PARAMETER	TEST CONDITIONS	MIN	NOM	MAX	UNIT
TIMING, OUTPUT TERMINALS					
f _{op}	Operating frequency			1500	kHz
t _{pd(if-O)}	Positive input falling to GHS_x falling	C _L = 1 nF	45		ns
t _{pd(ir-O)}	Positive input rising to GLS_x falling	C _L = 1 nF	45		ns
t _{dtp}	Dead time programming range ⁽¹⁾	R _{dtp} = 100 kΩ		110	ns
t _{r(GD)}	Rise time, gate drive output (0.5 to 3 V)	C _L = 1 nF	4.5		ns
t _{f(GD)}	Fall time, gate drive output (9 to 3 V)	C _L = 1 nF	7		ns
TIMING, PROTECTION, AND CONTROL					
t _{pd(R-SD)}	Delay, $\overline{\text{RESET}}$ low to SHUTDOWN high		40		ns
t _{pd(R-LH)}	Delay, $\overline{\text{RESET}}$ low to GLS_x high		44		ns
t _{pd(R-OP)}	Delay, $\overline{\text{RESET}}$ high to operation state		50		ns
t _{pd(E-L)}	Delay, error event to all gates low		180		ns
t _{pd(E-SD)}	Delay, error event to SHUTDOWN low		170		ns

⁽¹⁾ Dead time programming definition: Adjustable delay from AP (BP, CP, or DP) rising edge to GHS_A (GHS_B, GHS_C, or GHS_D) rising edge, and AM (BM, CM, or DM) rising edge to GLS_A (GLS_B, GLS_C, or GLS_D) rising edge.

Terminal Functions (continued)

TERMINAL NAME	NO.	I/O	DESCRIPTION
DHS_A	49	I	High-side drain connection, used for high-side V_{DS} sensing
DHS_B	43	I	High-side drain connection, used for high-side V_{DS} sensing
DHS_C	37	I	High-side drain connection, used for high-side V_{DS} sensing
DHS_D	31	I	High-side drain connection, used for high-side V_{DS} sensing
DTC_HS	6	I	High-side dead-time programming, external resistor to DV_{SS} required
DTC_LS	7	I	Low-side dead-time programming, external resistor to DV_{SS} required
DV _{DD}	3	P	Logic supply voltage
DV _{SS}	4, 24	P	Digital ground, reference for input signals
$\overline{ERR0}$	21	O	Logic output, signals chip operation mode/state. This output is open drain with internal pullup resistor.
ERR1	22	O	Logic output, signals chip operation mode/state. This output is open drain with internal pullup resistor.
GHS_A	51	O	Gate drive output for high-side MOSFET, half-bridge A
GHS_B	45	O	Gate drive output for high-side MOSFET, half-bridge B
GHS_C	39	O	Gate drive output for high-side MOSFET, half-bridge C
GHS_D	33	O	Gate drive output for high-side MOSFET, half-bridge D
GLS_A	54	O	Gate drive output for low-side MOSFET, half-bridge A
GLS_B	48	O	Gate drive output for low-side MOSFET, half-bridge B
GLS_C	42	O	Gate drive output for low-side MOSFET, half-bridge C
GLS_D	36	O	Gate drive output for low-side MOSFET, half-bridge D
GV _{DD}	30, 55	P	Gate drive voltage supply terminal
GV _{SS}	29, 56	P	Gate drive voltage supply ground return
LOW/HIZ	23	I	Logic signal that determines the drive output state during a reset. When $\overline{RESET_AB}$ or $\overline{RESET_CD}$ is low, LOW/HIZ = 1 indicates that the outputs are low impedance LOW/HIZ = 0 indicates that the outputs are high impedance
NC	1, 2, 5, 25, 26		Not connected. Terminals 1, 2, 5, 25, and 26 may be connected to DV_{SS} .
OC_HIGH	8	I	High-side overcurrent trip value programming. OC configuration circuit (see Figure 5) is required.
OC_LOW	27	I	Low-side overcurrent trip value programming. OC configuration circuit (see Figure 5) is required.
$\overline{RESET_AB}$	12	I	Reset signal half-bridge A and B, active low
$\overline{RESET_CD}$	17	I	Reset signal half-bridge C and D, active low
SHUTDOWN	20	O	Error/warning report indicator. This output is open drain with internal pull-up resistor.
SHS_A	52	I	High-side source connection, used as BST floating ground (and high-side V_{DS} sensing)
SHS_B	46	I	High-side source connection, used as BST floating ground (and high-side V_{DS} sensing)
SHS_C	40	I	High-side source connection, used as BST floating ground (and high-side V_{DS} sensing)
SHS_D	34	I	High-side source connection, used as BST floating ground (and high-side V_{DS} sensing)
SLS_A	53	I	Source connection low-side MOSFET, ground return terminal, half-bridge A
SLS_B	47	I	Source connection low-side MOSFET, ground return terminal, half-bridge B
SLS_C	41	I	Source connection low-side MOSFET, ground return terminal, half-bridge C
SLS_D	35	I	Source connection low-side MOSFET, ground return terminal, half-bridge D
TEMP	28	I	External temperature sensing connection
VRFILT	9	I	Bandgap reference = 1.8 V. Capacitor must be connected from VRFILT to DV_{SS} .

TAS5182

SLES045E - JUNE 2002 - REVISED MAY 2004

FUNCTIONAL BLOCK DIAGRAM

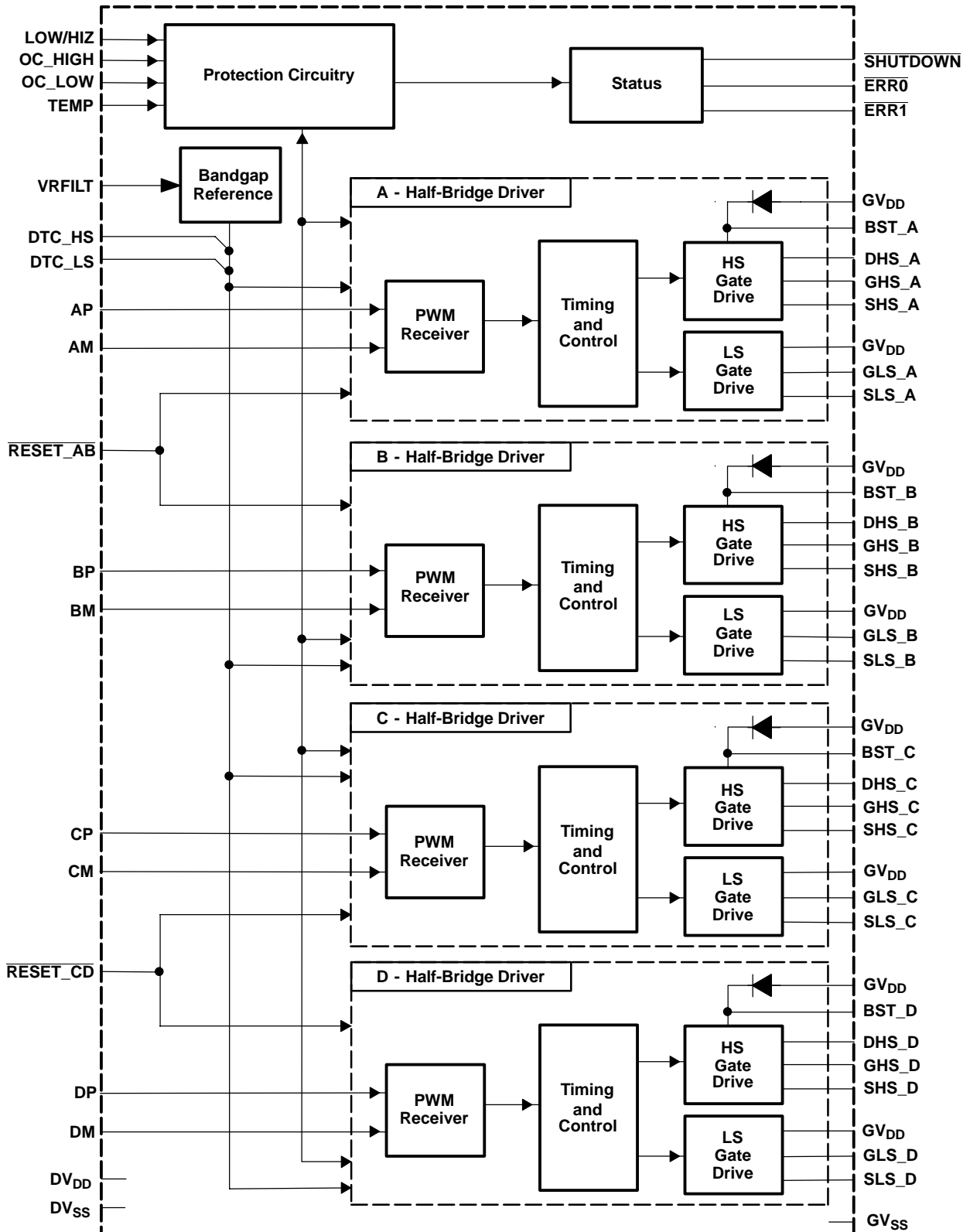

TIMING DIAGRAMS

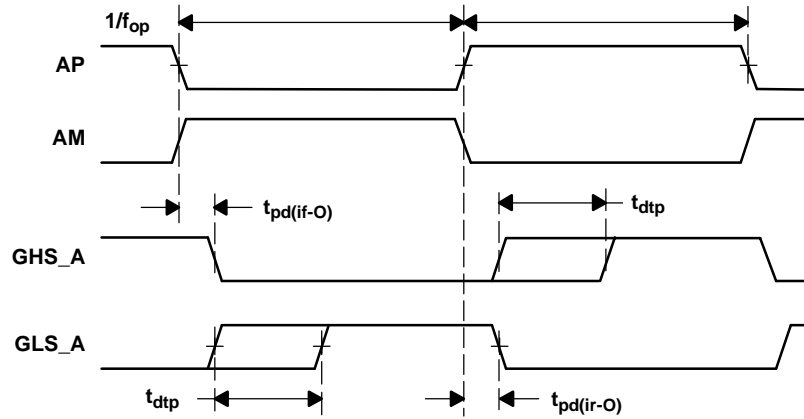

Figure 1. PWM Input to Gate Drive Output Timing (Same for A, B, C, and D Half-Bridge Drivers)

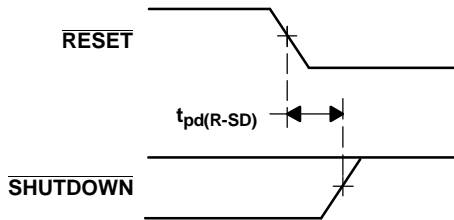

Figure 2. $\overline{\text{RESET}}$ to $\overline{\text{SHUTDOWN}}$ Propagation Delay

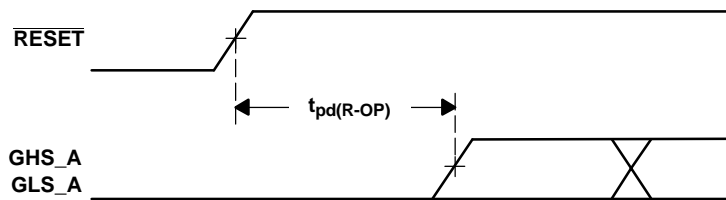
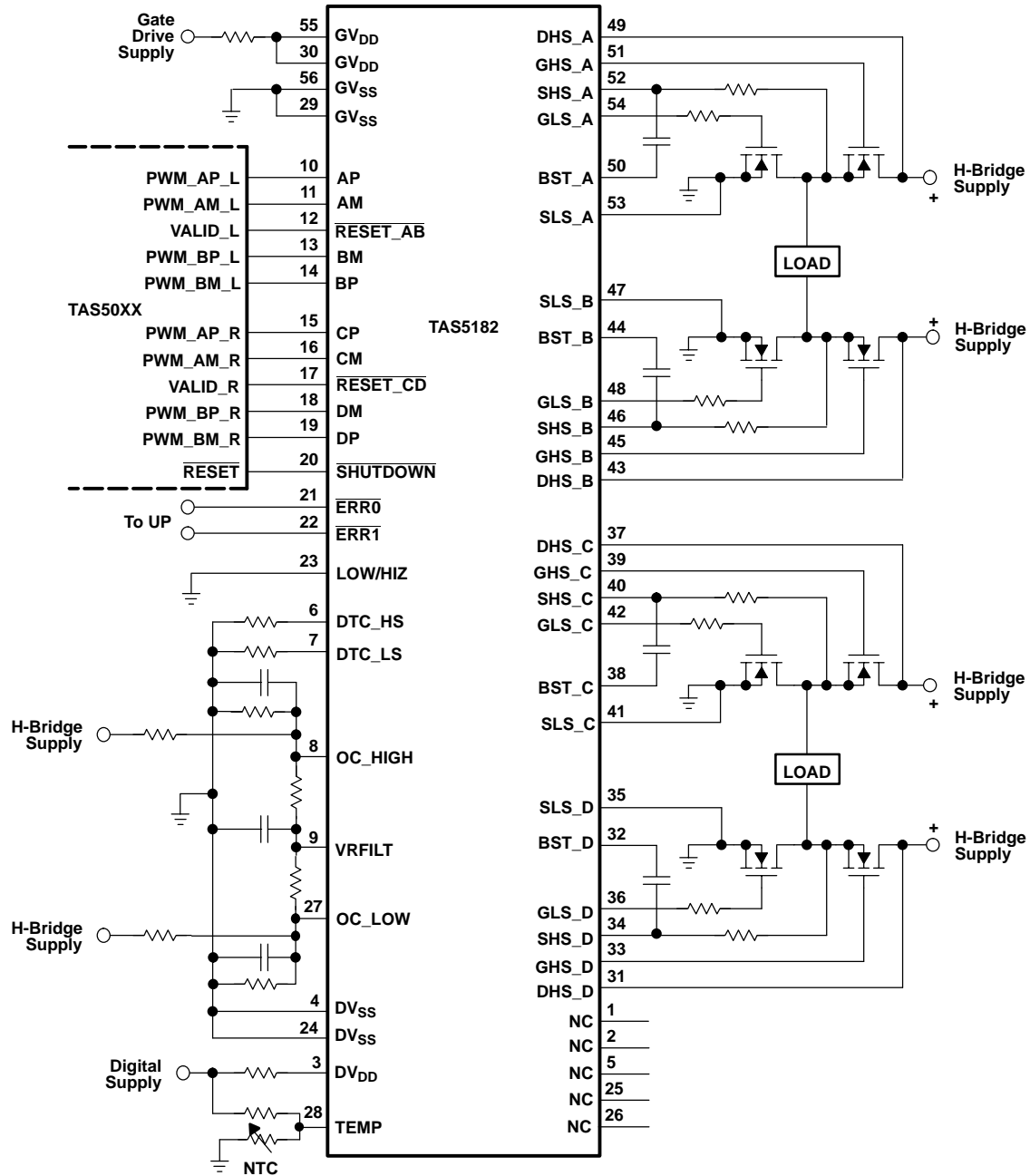

Figure 3. $\overline{\text{RESET}}$ to Gate Drive Output Propagation Delay (Same for Half-Bridge A, B, C, and D)

TAS5182

SLES045E - JUNE 2002 - REVISED MAY 2004

SIMPLIFIED APPLICATION CONNECTION DIAGRAM (BRIDGE-TIED-LOAD CONFIGURATION)



NOTE: Recommended power MOSFETs
International Rectifier IRFIZ24N (8 places)
For complete reference schematics contact Texas Instruments.

FUNCTIONAL DESCRIPTION

Power Stage Protection

The TAS5182 device provides overcurrent, overtemperature, and undervoltage protection for the MOSFET power stage.

Overcurrent Protection (OCP)

To protect the power stage from damage due to high currents, a V_{DS} sensing system is implemented in the TAS5182 device. Based on $R_{DS(on)}$ of the power MOSFETs and the maximum allowed I_{DS} , a voltage threshold can be calculated which, when exceeded, triggers the protection latch, causing the $\overline{SHUTDOWN}$ terminal to go low. This voltage threshold is resistor programmable. See the *Calculation of Overcurrent Resistor Values* section for more details.

Overtemperature Protection (OTP)

The TAS5182 device has a temperature protection system that uses an external negative temperature coefficient (NTC) resistor as a temperature sensor. See the *Overtemperature Programming Circuit* section for implementation details.

Undervoltage Protection (UVP)

To protect the power output stage during start-up, shutdown, and other possible undervoltage conditions, the TAS5182 device provides power stage undervoltage protection by driving its outputs low whenever GV_{DD} is under 7 V. With the TAS5182 outputs driven low, the MOSFETs go to a high-impedance state.

Control Terminals

The TAS5182 device provides input control terminals to reset each audio channel and also to control the electrical characteristics of the MOSFET output power stage.

Channel Reset

The reset function enables operation after power up, re-enables operation after an error event, and disables the MOSFET output stage switching during power down and mute. The falling edge of $\overline{RESET_AB}$ (left audio channel) or $\overline{RESET_CD}$ (right audio channel) causes the TAS5182 device to reset. The rising edge of $\overline{RESET_AB}$ or $\overline{RESET_CD}$ causes the TAS5182 device to clear the error latch and resume normal operation.

MOSFET Output Reset Control

The LOW/HIZ control terminal selects whether the MOSFET output stage goes into a high-impedance (HI-Z) state or LOW-LOW state when $\overline{RESET_AB}$ or $\overline{RESET_CD}$ is enabled. In the high-impedance state, the low-side and high-side MOSFETs are turned off causing no current flow through the MOSFETs. This effectively disconnects the load from the power supply rail. In the LOW-LOW state, the low-side MOSFETs are turned on, while the high-side MOSFETs are turned off. This causes a low or ground signal to be output to the load.

Status Terminals

The TAS5182 device provides output status terminals to report overcurrent, overtemperature, and undervoltage warnings and errors.

Shutdown Indicator

The $\overline{SHUTDOWN}$ terminal indicates an error event has occurred such as overcurrent, overtemperature, or undervoltage. The $\overline{SHUTDOWN}$ terminal is pulled high when $\overline{RESET_AB}$ or $\overline{RESET_CD}$ is asserted. $\overline{ERR0}$ and $\overline{ERR1}$ terminals along with the $\overline{SHUTDOWN}$ terminal indicate the type of warnings and errors. Note that $\overline{SHUTDOWN}$ is an open-drain signal. See Table 1 for a functional description of these signals.

Table 1. TAS5182 Status Signals

ERR0	ERR1	SHUTDOWN	DESCRIPTION
0	0	0	Multiple errors (TAS5182 gate outputs low, MOSFET outputs HI-Z)
0	0	1	Not valid
0	1	0	Overtemperature error (TAS5182 gate outputs low, MOSFET outputs HI-Z)
0	1	1	Overtemperature warning (normal operation)
1	0	0	Overcurrent error (TAS5182 gate outputs low, MOSFET outputs HI-Z)
1	0	1	Not valid
1	1	0	GV_{DD} undervoltage error (TAS5182 gate outputs low, MOSFET outputs HI-Z)
1	1	1	Normal operation

TAS5182 Power Up and Reset

After power up, all gate drive outputs are held low (i.e., the error latch is set). Normal operation can be initiated by toggling $\overline{\text{RESET_AB}}$ and/or $\overline{\text{RESET_CD}}$ from a low state to a high state. If no errors are present, then the TAS5182 device is ready to accept audio inputs.

TAS5182 Reset and Error Timing

The TAS5182 device provides two output control configurations for reset and error situations. In a BTL system configuration, the MOSFET outputs must be grounded before resuming normal operation. This enables the bootstrap capacitors to charge.

Reset and Error Timing (BTL System)

When using this device in the BTL configuration, it is advisable to bring the MOSFET outputs to a high impedance state when reset ($\overline{\text{RESET_AB}}$ or $\overline{\text{RESET_CD}}$)

is asserted. Figure 4 shows the timing that occurs in this configuration. This feature is enabled by connecting the LOW/HIZ terminal to DV_{SS}.

When an error event occurs (see Table 1) and following propagation delay $t_{pd(E-SD)}$, the TAS5182 device pulls the $\overline{\text{SHUTDOWN}}$ signal low. The falling edge of $\overline{\text{SHUTDOWN}}$ forces the MOSFET outputs into a high-impedance state. The $\overline{\text{SHUTDOWN}}$ signal is usually connected to the $\overline{\text{RESET}}$ terminal of the TAS50XX PWM controller. After some delay, the controller then asserts the TAS5182 $\overline{\text{RESET_AB}}$ and $\overline{\text{RESET_CD}}$ terminals low. The falling edge of $\overline{\text{RESET}}$ forces the MOSFET outputs to ground potential (this event also brings the $\overline{\text{SHUTDOWN}}$ signal high). This allows the bootstrap capacitors to charge through the grounded MOSFET outputs. When $\overline{\text{RESET}}$ is pulled high, the system resumes normal operation.

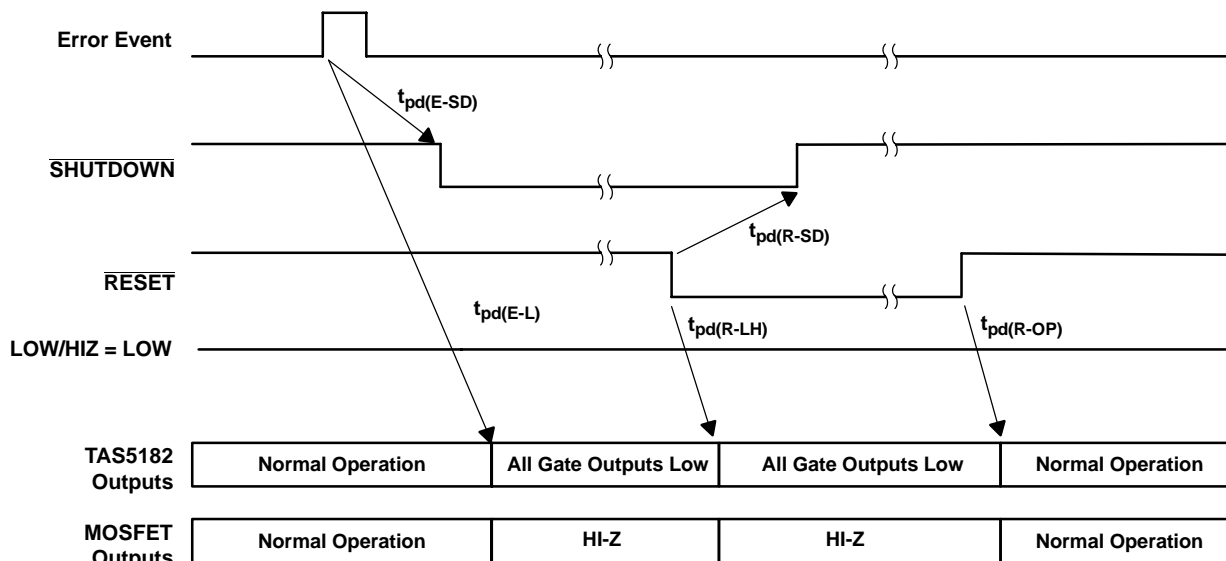

Figure 4. Reset and Error Timing (BTL System)

Overcurrent Configuration From Circuit

The output current flows through internal resistance $R_{DS(on)}$ of the external MOSFETs, which creates voltage drop V_{DS} . The overcurrent detector senses this voltage to trigger an error event. The exact current limit depends on parasitics from the PCB layout, resistance of the MOSFET at the operation temperature, and the configuration of the H-bridge output stage.

See Table 2 for the OCL and OCH reference voltages. Figure 5 shows the recommended overcurrent configuration circuit.

Table 2. OCL and OCH Reference Voltages (Overcurrent Configuration Circuit)

	VOLTAGE	OUTPUT INDUCTOR SHUTDOWN CURRENT RANGE ⁽¹⁾
OCL	0.7 V (terminal 27)	12-19 A
OCH	1.17 V (terminal 8)	14-24 A

⁽¹⁾ Measured on Texas Instruments reference board TAS5182C6REF.

Board configuration:

- 1R0 resistors on SHS and GLS connections
- $GV_{DD} = 12\text{ V}$, $PV_{DD} = 40\text{ V}$
- 10BQ060 voltage clamp on output node
- TT snubbers: $L = 75\text{ nH}$, $C = 10\text{ nF}$, $R = 5.4\ \Omega$

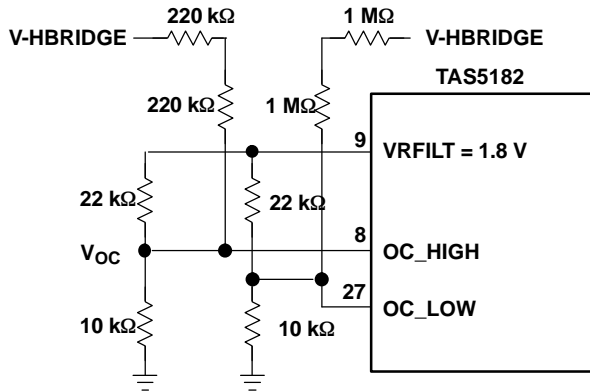

Figure 5. Overcurrent Configuration Circuit

Overtemperature Programming Circuit

The TAS5182 device features a temperature protection system that uses an external negative temperature coefficient (NTC) resistor as a temperature sensor. Figure 6 shows a typical application.

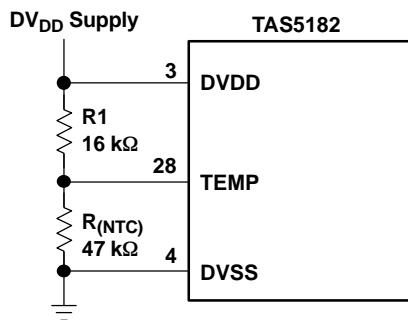

Figure 6. Temperature Sensing Circuit

The temperature protection system has two trigger limits: OT warning and OT error. OT warning occurs when the voltage at the TEMP terminal is approximately 36% of

DV_{DD} . OT error occurs when the voltage at the TEMP terminal is approximately 23% of DV_{DD} . OT warning is decoded when $\overline{ERR0} = 0$, $\overline{ERR1} = 1$, and $\overline{SHUTDOWN} = 1$. OT error is decoded when $\overline{ERR0} = 0$, $\overline{ERR1} = 1$, and $\overline{SHUTDOWN} = 0$. The user for a particular application determines the values of $R1$ and R_{NTC} . Typical values are $R1 = 16\text{ k}\Omega$ and $R_{NTC} = 47\text{ k}\Omega$.

THERMAL INFORMATION

The thermally enhanced DCA package is based on the 56-pin HTSSOP, but includes a thermal pad (see Figure 7) to provide an effective thermal contact between the IC and the PCB.

Traditionally, surface mount and power have been mutually exclusive terms. A variety of scaled-down TO-220 type packages have leads formed as gull wings to make them applicable for surface-mount applications. These packages, however, have two shortcomings: they do not address the low profile requirements ($< 2\text{ mm}$) of many of today's advanced systems and they do not offer a terminal count high enough to accommodate increasing integration. However, traditional low-power, surface-mount packages require power-dissipation derating that severely limits the usable range of many high-performance analog circuits.

The PowerPAD™ package (thermally enhanced HTSSOP) combines fine-pitch, surface-mount technology with thermal performance comparable to much larger power packages.

The PowerPAD package is designed to optimize the heat transfer to the PCB. Because of the small size and limited mass of a HTSSOP package, thermal enhancement is achieved by improving the thermal conduction paths that remove heat from the component. The thermal pad is formed using a patented lead-frame design and manufacturing technique to provide a direct connection to the heat-generating IC. When this pad is soldered to the PCB, good power dissipation in the ultrathin, fine-pitch, surface-mount package can be reliably achieved. See Reference 4 for recommended soldering procedure.

THERMAL DATA

PARAMETER		MIN	TYP	MAX	UNIT
Junction temperature, $T_{J(SD)}$				150	$^{\circ}\text{C}$
Operating temperature, T_C	Commercial	0	25	70	$^{\circ}\text{C}$
	Industrial	-40	25	85	$^{\circ}\text{C}$
Thermal resistance, θ_{jc}	Pad with solder ⁽¹⁾	0.27			$^{\circ}\text{C/W}$
Thermal resistance, θ_{ja}		21.17			$^{\circ}\text{C/W}$
Thermal resistance, θ_{jc}	Pad without solder ⁽¹⁾	0.27			$^{\circ}\text{C/W}$
Thermal resistance, θ_{ja}		36.42			$^{\circ}\text{C/W}$

(1) Values taken from Table 6 *Thermal Characteristics for Different Package and PCB Configurations* of the *PowerPAD Thermally Enhanced Package* application note (SLMA002). See pages 32 and 33 for a description of the printed circuit board (PCB) used for these measurements. Note that the PCB used for these measurements is not the recommended PCB for TAS5182 applications but is cited here for reference only.

Power Dissipation

The equation for TAS5182 power dissipation using N external MOSFETs is:

$$P_d = V_{gd} \times Q_g \times f \times N$$

where:

$$V_{gd} = GV_{DD} \text{ (typically 12 V)}$$

$$Q_g = \text{MOSFET gate charge}$$

f = operating frequency

N = number of external MOSFETs driven (eight for two-channel operation)

Example power dissipation calculation:

Given a TAS5182 system with eight external IRFIZ24N MOSFETs and $GV_{DD} = 12 \text{ V}$. The power dissipation is:

$$P_d = V_{gd} \times Q_g \times f \times N = 12\text{V} \times 22.5\text{nC} \times 384 \text{ kHz} \times 8 = 0.8 \text{ W}$$

Note: Lab measurements yield a power dissipation of 0.8 W ($PV_{DD} = 40 \text{ V}$).

REFERENCES

1. *TAS5000 Digital Audio PWM Process data manual*, Texas Instruments Literature Number SLAS270
2. *System Design Considerations for True Digital Audio Power Amplifiers*, Texas Instruments Literature Number SLAA117
3. *Digital Audio Measurements*, Texas Instruments Literature Number SLAA114
4. *PowerPAD Thermally Enhanced Package*, Texas Instruments Literature Number SLMA002

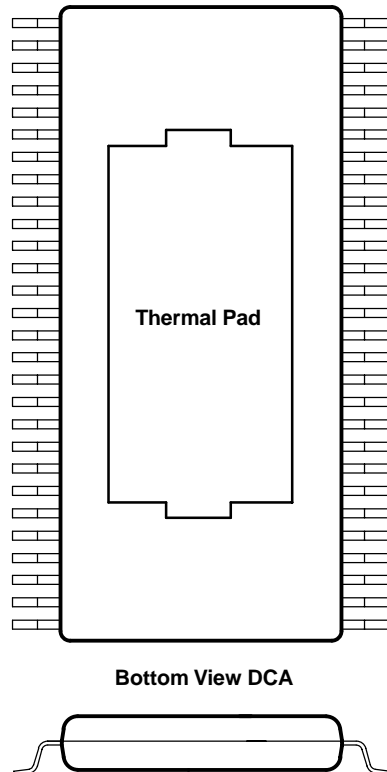
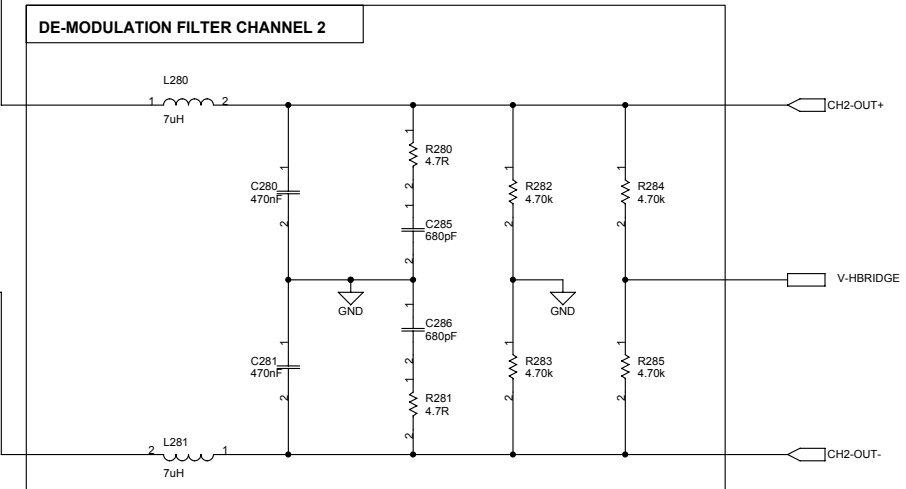
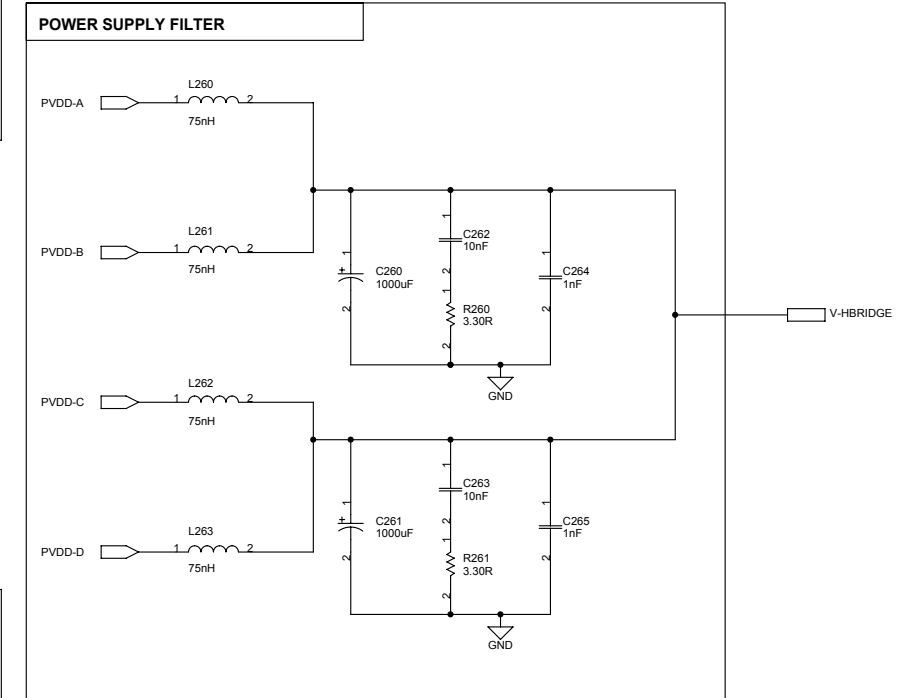
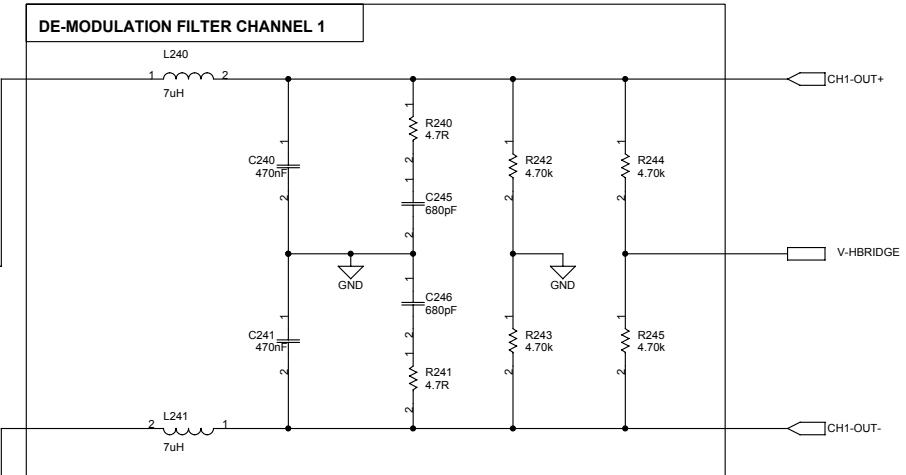
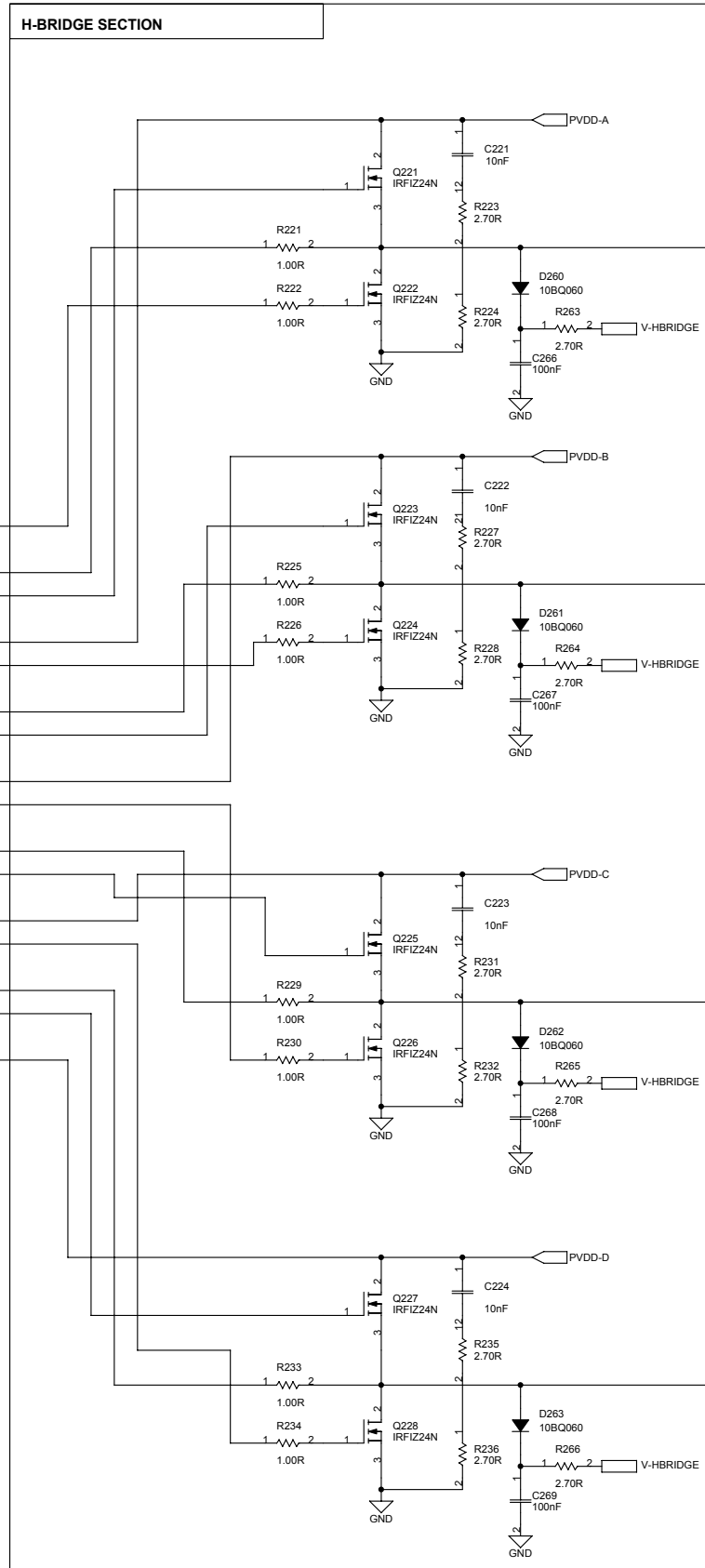
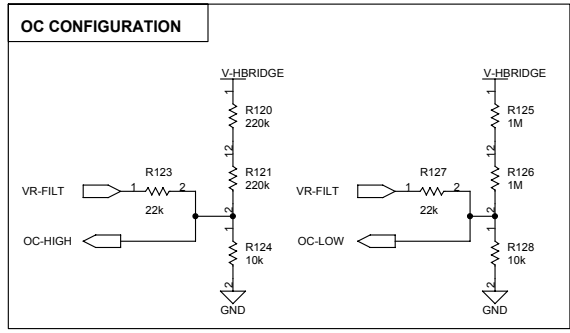
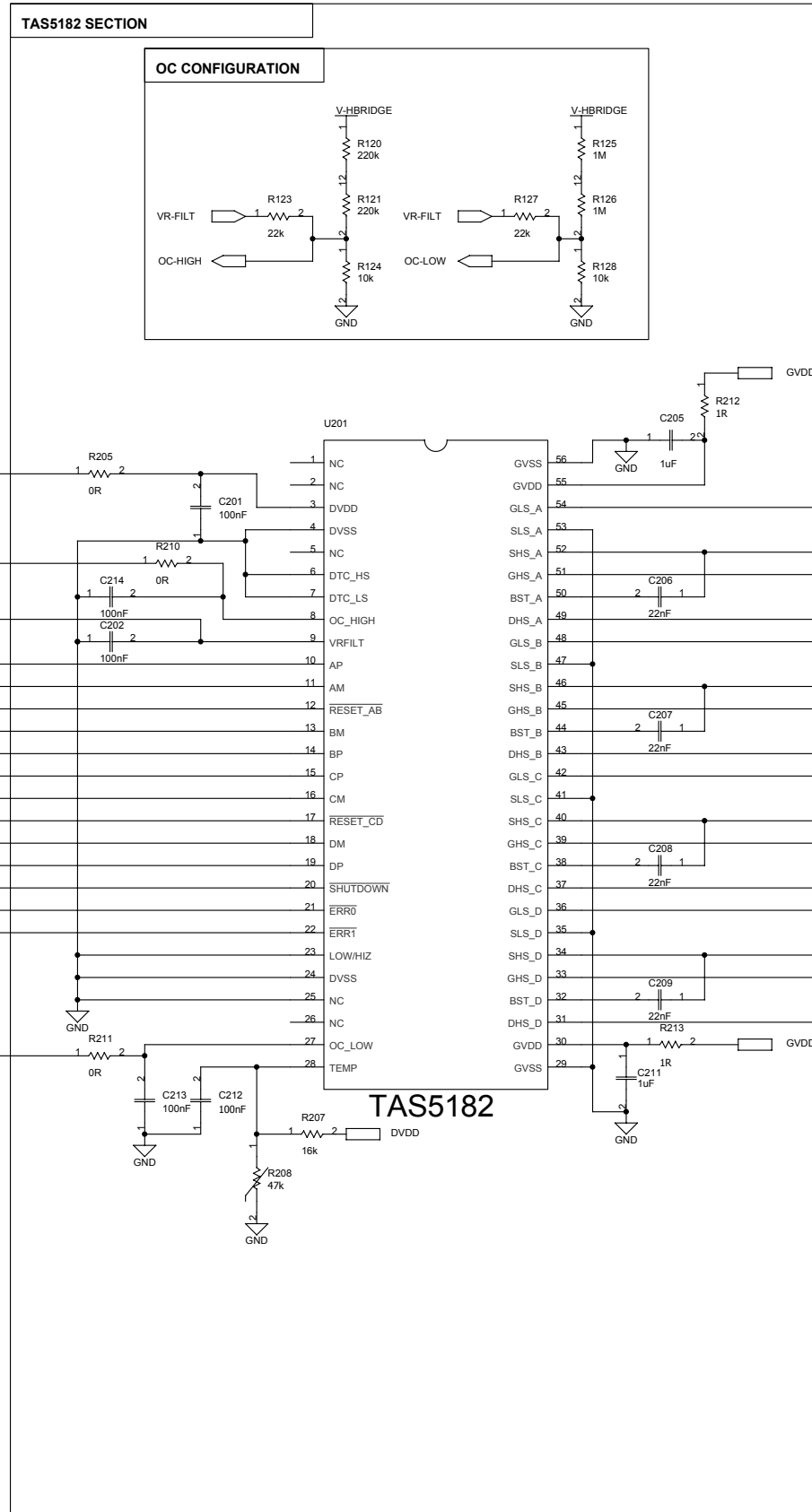

Figure 7. Views of a Thermally Enhanced DCA Package

TAS5182 OUTPUT STAGE

To/From Texas Instruments TAS5036 PWM Modulator



TI		DIGITAL AUDIO & VIDEO DIVISION	
ALL RIGHTS RESERVED - PATENTS PENDING			
TEXAS INSTRUMENTS INCORPORATED			
Project: TAS5182C8REF	Rev: 6.00		
Page Title: CHANNEL 1 & CHANNEL 2	Size:		
File Name:	Engineer:		
Date:	Page: of		

Patents pending in circuitry design and layout (WO99/59241 & WO99/59242).
This circuitry may only be used together with the integrated circuit TAS5100/TAS5110/TAS5111/TAS5112/TAS5182 from Texas Instruments Incorporated.

PACKAGING INFORMATION

Orderable Device	Status ⁽¹⁾	Package Type	Package Drawing	Pins	Package Qty	Eco Plan ⁽²⁾	Lead/ Ball Finish	MSL Peak Temp ⁽³⁾	Samples (Requires Login)
TAS5182DCA	ACTIVE	HTSSOP	DCA	56	35	Green (RoHS & no Sb/Br)	CU NIPDAU	Level-3-260C-168 HR	Request Free Samples
TAS5182DCAG4	ACTIVE	HTSSOP	DCA	56	35	Green (RoHS & no Sb/Br)	CU NIPDAU	Level-3-260C-168 HR	Request Free Samples
TAS5182DCAR	ACTIVE	HTSSOP	DCA	56	2000	Green (RoHS & no Sb/Br)	CU NIPDAU	Level-3-260C-168 HR	Purchase Samples
TAS5182DCARG4	ACTIVE	HTSSOP	DCA	56	2000	Green (RoHS & no Sb/Br)	CU NIPDAU	Level-3-260C-168 HR	Purchase Samples
TAS5182IDCA	ACTIVE	HTSSOP	DCA	56	35	Green (RoHS & no Sb/Br)	CU NIPDAU	Level-3-260C-168 HR	Request Free Samples
TAS5182IDCAG4	ACTIVE	HTSSOP	DCA	56	35	Green (RoHS & no Sb/Br)	CU NIPDAU	Level-3-260C-168 HR	Request Free Samples
TAS5182IDCAR	ACTIVE	HTSSOP	DCA	56		TBD	Call TI	Call TI	Purchase Samples
TAS5182IDCARG4	ACTIVE	HTSSOP	DCA	56		TBD	Call TI	Call TI	Purchase Samples

⁽¹⁾ The marketing status values are defined as follows:

ACTIVE: Product device recommended for new designs.

LIFEBUY: TI has announced that the device will be discontinued, and a lifetime-buy period is in effect.

NRND: Not recommended for new designs. Device is in production to support existing customers, but TI does not recommend using this part in a new design.

PREVIEW: Device has been announced but is not in production. Samples may or may not be available.

OBSELETE: TI has discontinued the production of the device.

⁽²⁾ Eco Plan - The planned eco-friendly classification: Pb-Free (RoHS), Pb-Free (RoHS Exempt), or Green (RoHS & no Sb/Br) - please check <http://www.ti.com/productcontent> for the latest availability information and additional product content details.

TBD: The Pb-Free/Green conversion plan has not been defined.

Pb-Free (RoHS): TI's terms "Lead-Free" or "Pb-Free" mean semiconductor products that are compatible with the current RoHS requirements for all 6 substances, including the requirement that lead not exceed 0.1% by weight in homogeneous materials. Where designed to be soldered at high temperatures, TI Pb-Free products are suitable for use in specified lead-free processes.

Pb-Free (RoHS Exempt): This component has a RoHS exemption for either 1) lead-based flip-chip solder bumps used between the die and package, or 2) lead-based die adhesive used between the die and leadframe. The component is otherwise considered Pb-Free (RoHS compatible) as defined above.

Green (RoHS & no Sb/Br): TI defines "Green" to mean Pb-Free (RoHS compatible), and free of Bromine (Br) and Antimony (Sb) based flame retardants (Br or Sb do not exceed 0.1% by weight in homogeneous material)

⁽³⁾ MSL, Peak Temp. -- The Moisture Sensitivity Level rating according to the JEDEC industry standard classifications, and peak solder temperature.

Important Information and Disclaimer: The information provided on this page represents TI's knowledge and belief as of the date that it is provided. TI bases its knowledge and belief on information provided by third parties, and makes no representation or warranty as to the accuracy of such information. Efforts are underway to better integrate information from third parties. TI has taken and

continues to take reasonable steps to provide representative and accurate information but may not have conducted destructive testing or chemical analysis on incoming materials and chemicals. TI and TI suppliers consider certain information to be proprietary, and thus CAS numbers and other limited information may not be available for release.

In no event shall TI's liability arising out of such information exceed the total purchase price of the TI part(s) at issue in this document sold by TI to Customer on an annual basis.

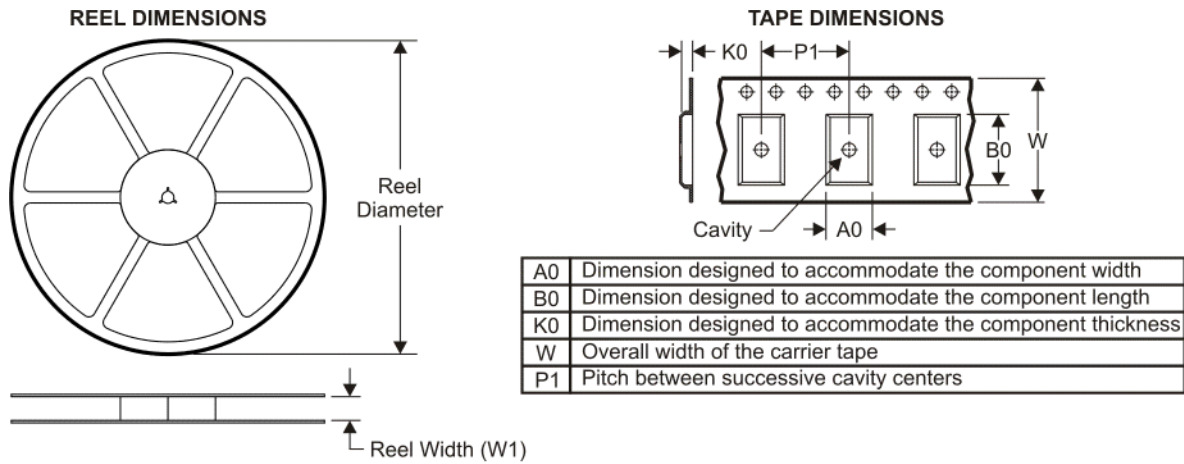
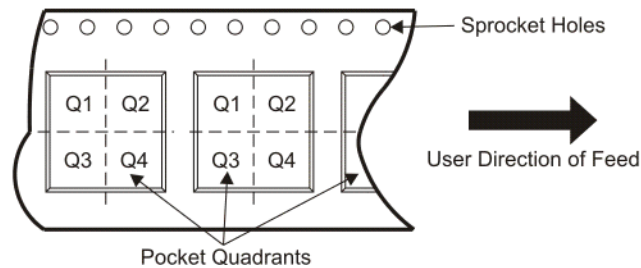
TAPE AND REEL INFORMATION

QUADRANT ASSIGNMENTS FOR PIN 1 ORIENTATION IN TAPE

*All dimensions are nominal

Device	Package Type	Package Drawing	Pins	SPQ	Reel Diameter (mm)	Reel Width W1 (mm)	A0 (mm)	B0 (mm)	K0 (mm)	P1 (mm)	W (mm)	Pin1 Quadrant
TAS5182DCAR	HTSSOP	DCA	56	2000	330.0	24.4	8.6	15.6	1.8	12.0	24.0	Q1

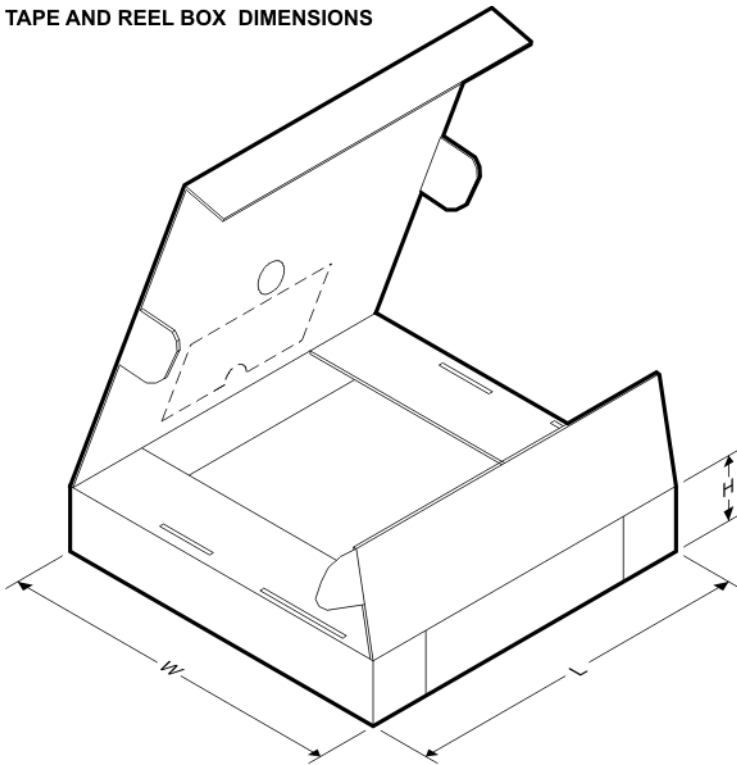
TAPE AND REEL BOX DIMENSIONS



*All dimensions are nominal

Device	Package Type	Package Drawing	Pins	SPQ	Length (mm)	Width (mm)	Height (mm)
TAS5182DCAR	HTSSOP	DCA	56	2000	346.0	346.0	41.0

MECHANICAL DATA

DCA (R-PDSO-G56)

PowerPAD™ PLASTIC SMALL-OUTLINE

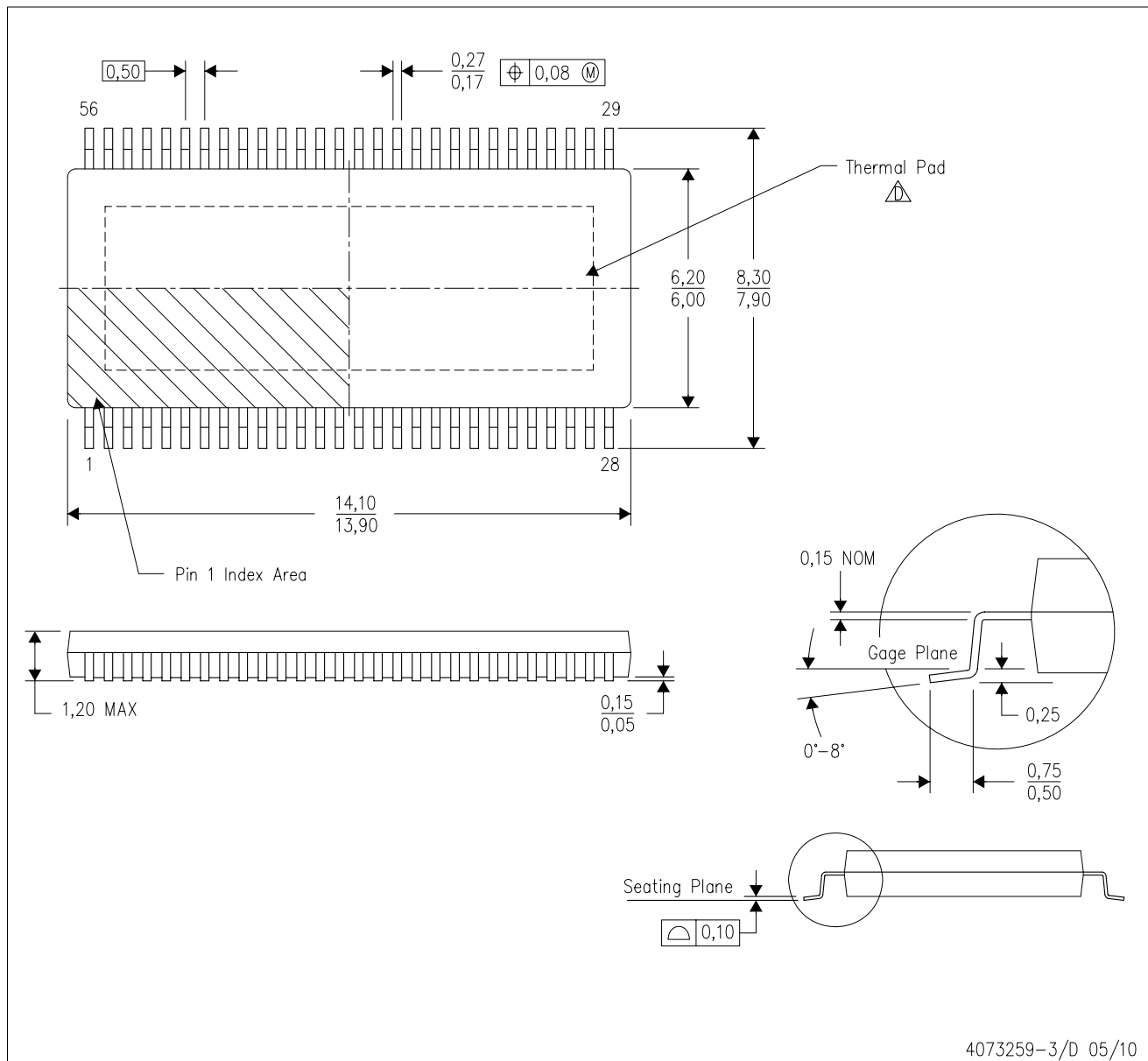

- NOTES:
- All linear dimensions are in millimeters. Dimensioning and tolerancing per ASME Y14.5M-1994.
 - This drawing is subject to change without notice.
 - Body dimensions do not include mold flash or protrusion not to exceed 0,15.
 - This package is designed to be soldered to a thermal pad on the board. Refer to Technical Brief, PowerPad Thermally Enhanced Package, Texas Instruments Literature No. SLMA002 for information regarding recommended board layout. This document is available at www.ti.com <<http://www.ti.com>>.
 - Falls within JEDEC MO-153

PowerPAD is a trademark of Texas Instruments.

THERMAL PAD MECHANICAL DATA

DCA (R-PDSO-G56)

PowerPAD™ PLASTIC SMALL OUTLINE

THERMAL INFORMATION

This PowerPAD™ package incorporates an exposed thermal pad that is designed to be attached to a printed circuit board (PCB). The thermal pad must be soldered directly to the PCB. After soldering, the PCB can be used as a heatsink. In addition, through the use of thermal vias, the thermal pad can be attached directly to the appropriate copper plane shown in the electrical schematic for the device, or alternatively, can be attached to a special heatsink structure designed into the PCB. This design optimizes the heat transfer from the integrated circuit (IC).

For additional information on the PowerPAD package and how to take advantage of its heat dissipating abilities, refer to Technical Brief, PowerPAD Thermally Enhanced Package, Texas Instruments Literature No. SLMA002 and Application Brief, PowerPAD Made Easy, Texas Instruments Literature No. SLMA004. Both documents are available at www.ti.com.

The exposed thermal pad dimensions for this package are shown in the following illustration.

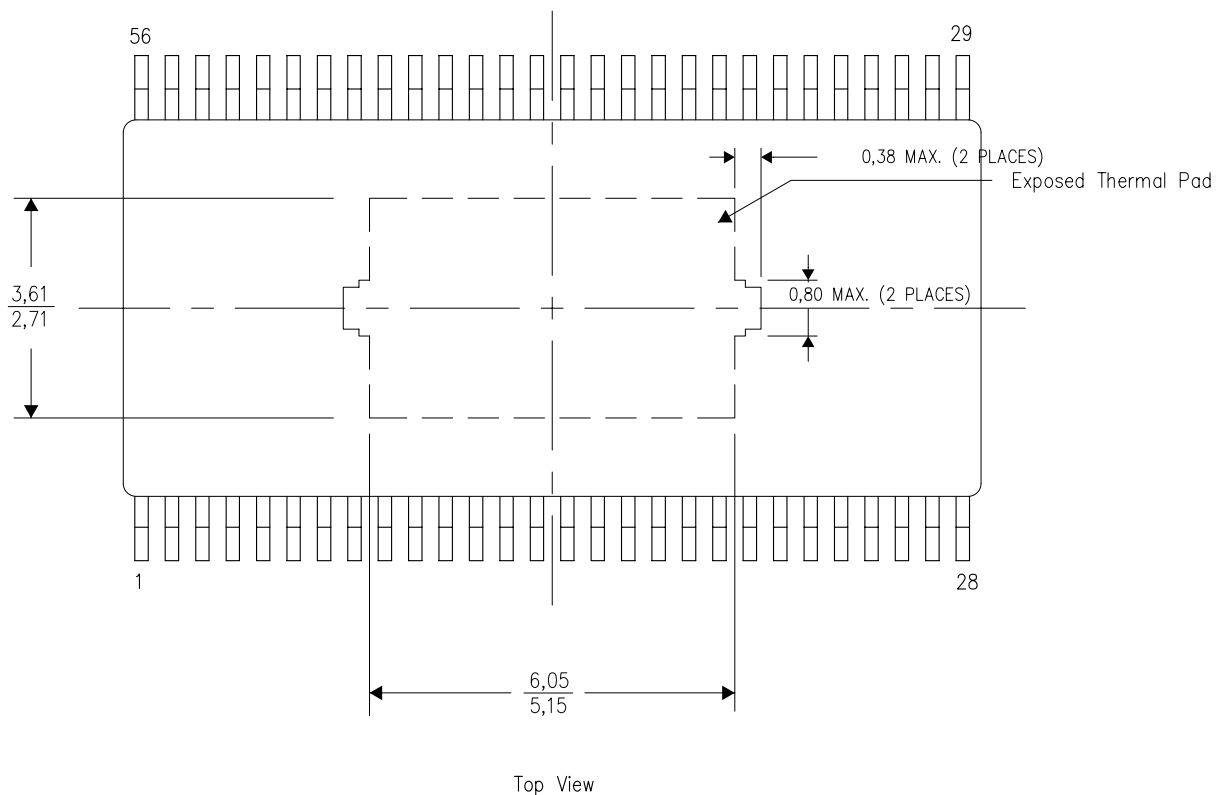

NOTE: All linear dimensions are in millimeters

NOTE: Keep-out features are identified to prevent board routing interference.

These exposed metal features may vary within the identified area or completely absent on some devices.

Exposed Thermal Pad Dimensions

4206320-8/K 04/10

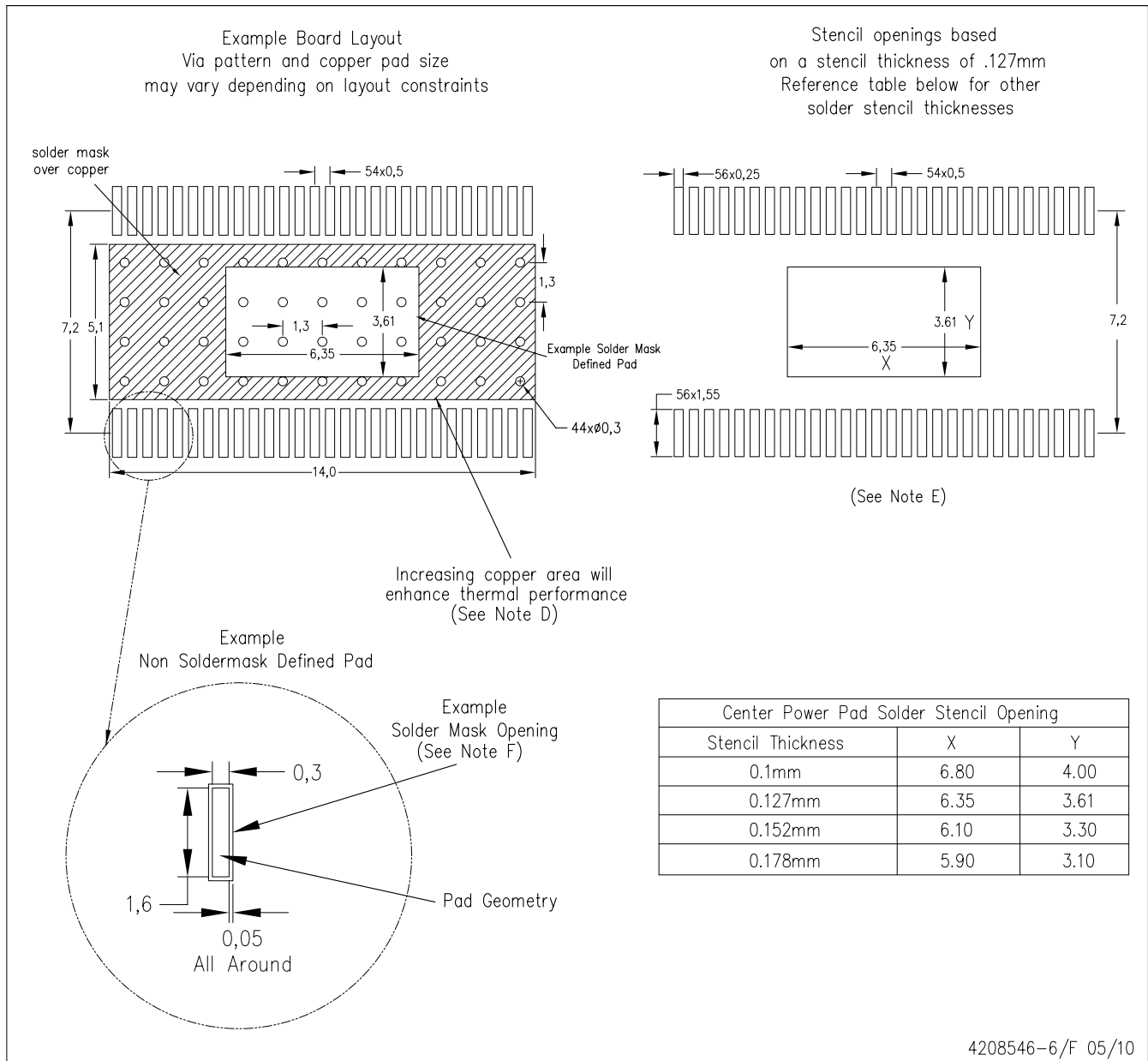

- NOTES:
- All linear dimensions are in millimeters.
 - This drawing is subject to change without notice.
 - Customers should place a note on the circuit board fabrication drawing not to alter the center solder mask defined pad.
 - This package is designed to be soldered to a thermal pad on the board. Refer to Technical Brief, PowerPAD Thermally Enhanced Package, Texas Instruments Literature No. SLMA002, SLMA004, and also the Product Data Sheets for specific thermal information, via requirements, and recommended board layout. These documents are available at www.ti.com <<http://www.ti.com>>. Publication IPC-7351 is recommended for alternate designs.
 - Laser cutting apertures with trapezoidal walls and also rounding corners will offer better paste release. Customers should contact their board assembly site for stencil design recommendations. Example stencil design based on a 50% volumetric metal load solder paste. Refer to IPC-7525 for other stencil recommendations.
 - Customers should contact their board fabrication site for solder mask tolerances between and around signal pads.

IMPORTANT NOTICE

Texas Instruments Incorporated and its subsidiaries (TI) reserve the right to make corrections, modifications, enhancements, improvements, and other changes to its products and services at any time and to discontinue any product or service without notice. Customers should obtain the latest relevant information before placing orders and should verify that such information is current and complete. All products are sold subject to TI's terms and conditions of sale supplied at the time of order acknowledgment.

TI warrants performance of its hardware products to the specifications applicable at the time of sale in accordance with TI's standard warranty. Testing and other quality control techniques are used to the extent TI deems necessary to support this warranty. Except where mandated by government requirements, testing of all parameters of each product is not necessarily performed.

TI assumes no liability for applications assistance or customer product design. Customers are responsible for their products and applications using TI components. To minimize the risks associated with customer products and applications, customers should provide adequate design and operating safeguards.

TI does not warrant or represent that any license, either express or implied, is granted under any TI patent right, copyright, mask work right, or other TI intellectual property right relating to any combination, machine, or process in which TI products or services are used. Information published by TI regarding third-party products or services does not constitute a license from TI to use such products or services or a warranty or endorsement thereof. Use of such information may require a license from a third party under the patents or other intellectual property of the third party, or a license from TI under the patents or other intellectual property of TI.

Reproduction of TI information in TI data books or data sheets is permissible only if reproduction is without alteration and is accompanied by all associated warranties, conditions, limitations, and notices. Reproduction of this information with alteration is an unfair and deceptive business practice. TI is not responsible or liable for such altered documentation. Information of third parties may be subject to additional restrictions.

Resale of TI products or services with statements different from or beyond the parameters stated by TI for that product or service voids all express and any implied warranties for the associated TI product or service and is an unfair and deceptive business practice. TI is not responsible or liable for any such statements.

TI products are not authorized for use in safety-critical applications (such as life support) where a failure of the TI product would reasonably be expected to cause severe personal injury or death, unless officers of the parties have executed an agreement specifically governing such use. Buyers represent that they have all necessary expertise in the safety and regulatory ramifications of their applications, and acknowledge and agree that they are solely responsible for all legal, regulatory and safety-related requirements concerning their products and any use of TI products in such safety-critical applications, notwithstanding any applications-related information or support that may be provided by TI. Further, Buyers must fully indemnify TI and its representatives against any damages arising out of the use of TI products in such safety-critical applications.

TI products are neither designed nor intended for use in military/aerospace applications or environments unless the TI products are specifically designated by TI as military-grade or "enhanced plastic." Only products designated by TI as military-grade meet military specifications. Buyers acknowledge and agree that any such use of TI products which TI has not designated as military-grade is solely at the Buyer's risk, and that they are solely responsible for compliance with all legal and regulatory requirements in connection with such use.

TI products are neither designed nor intended for use in automotive applications or environments unless the specific TI products are designated by TI as compliant with ISO/TS 16949 requirements. Buyers acknowledge and agree that, if they use any non-designated products in automotive applications, TI will not be responsible for any failure to meet such requirements.

Following are URLs where you can obtain information on other Texas Instruments products and application solutions:

Products		Applications	
Amplifiers	amplifier.ti.com	Audio	www.ti.com/audio
Data Converters	dataconverter.ti.com	Automotive	www.ti.com/automotive
DLP® Products	www.dlp.com	Communications and Telecom	www.ti.com/communications
DSP	dsp.ti.com	Computers and Peripherals	www.ti.com/computers
Clocks and Timers	www.ti.com/clocks	Consumer Electronics	www.ti.com/consumer-apps
Interface	interface.ti.com	Energy	www.ti.com/energy
Logic	logic.ti.com	Industrial	www.ti.com/industrial
Power Mgmt	power.ti.com	Medical	www.ti.com/medical
Microcontrollers	microcontroller.ti.com	Security	www.ti.com/security
RFID	www.ti-rfid.com	Space, Avionics & Defense	www.ti.com/space-avionics-defense
RF/IF and ZigBee® Solutions	www.ti.com/lprf	Video and Imaging	www.ti.com/video
		Wireless	www.ti.com/wireless-apps