



# STS4DPFS30L

## P-CHANNEL 30V - 0.045Ω - 5A SO-8 STripFET™ MOSFET PLUS SCHOTTKY RECTIFIER

**Table 1: General Features**

MOSFET TYPE	V <sub>DSS</sub>	R <sub>DS(on)</sub>	I <sub>D</sub>
STS4DPFS30L	30 V	< 0.055 Ω	5 A
SCHOTTKY	I <sub>F(AV)</sub>	V <sub>RRM</sub>	V <sub>F(MAX)</sub>
	3 A	30 V	0.51 V

- TYPICAL R<sub>DS(on)</sub> = 0.045 Ω
- CONDUCTION LOSSES REDUCED
- SWITCHING LOSSES REDUCED
- LOW THRESHOLD DRIVE
- STANDARD OUTLINE FOR EASY AUTOMATED SURFACE MOUNT ASSEMBLY

### DESCRIPTION

This MOSFET is the latest development of STMicroelectronics unique "Single Feature Size™" strip-based process. The resulting transistor shows extremely high packing density for low on-resistance, rugged avalanche characteristics and less critical alignment steps therefore a remarkable manufacturing reproducibility.

### APPLICATIONS

- DC/DC CONVERTERS
- BATTERY MANAGEMENT IN NOMADIC EQUIPMENT
- POWER MANAGEMENT IN CELLULAR PHONES
- DC MOTOR DRIVE

**Figure 1: Package**

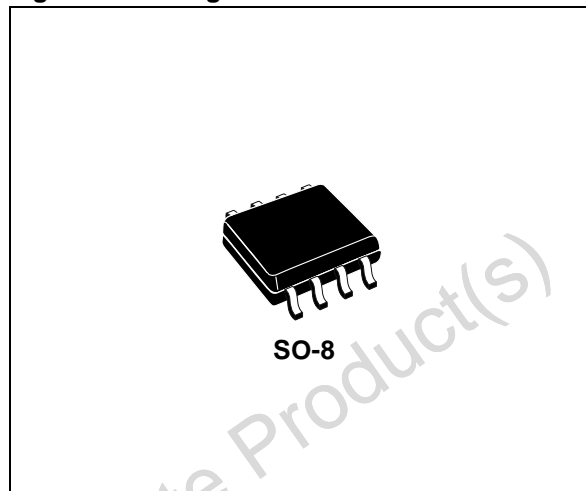

**Figure 2: Internal Schematic Diagram**

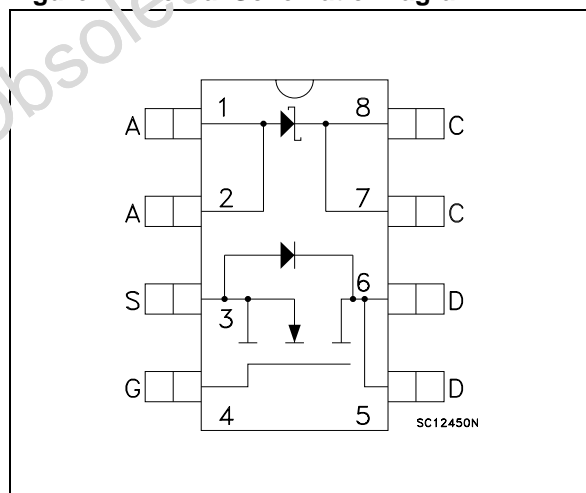

**Table 2: Order Codes**

PART NUMBER	MARKING	PACKAGE	PACKAGING
STS4DPF30L	4DFS30L	SO-8	TAPE & REEL

**Table 3: MOSFET Absolute Maximum Ratings**

Symbol	Parameter	Value	Unit
V <sub>DS</sub>	Drain-source Voltage (V <sub>GS</sub> = 0)	30	V
V <sub>DGR</sub>	Drain-gate Voltage (R <sub>GS</sub> = 20 kΩ)	30	V
V <sub>GS</sub>	Gate- source Voltage	± 16	V
I <sub>D</sub>	Drain Current (continuous) at T <sub>C</sub> = 25°C Single Operating	5	A
I <sub>D</sub>	Drain Current (continuous) at T <sub>C</sub> = 100°C Single Operating	4	A
I <sub>DM</sub> (•)	Drain Current (pulsed)	20	A
P <sub>TOT</sub>	Total Dissipation at T <sub>C</sub> = 25°C Single Operating	2.5	W
T <sub>j</sub> T <sub>stg</sub>	Operating Junction Temperature Storage Temperature	150 -55 to 150	°C °C

(•) Pulse width limited by safe operating area

Note: For the P-CHANNEL MOSFET actual polarity of voltages and current has to be reversed

**Table 4: Schottky Absolute Maximum Ratings**

Symbol	Parameter		Value	Unit
V <sub>RRM</sub>	Repetitive Peak Reverse Voltage		30	V
I <sub>F(RMS)</sub>	RMS Forward Current		20	A
I <sub>F(AV)</sub>	Average Forward Current	T <sub>L</sub> = 125°C δ = 0.5	3	A
I <sub>FSM</sub>	Surge Non Repetitive Forward Current	t <sub>p</sub> = 10 ms Sinusoidal	75	A
I <sub>RRM</sub>	Repetitive Peak Reverse Current	t <sub>p</sub> = 2 μs F = 1 kHz	1	A
I <sub>RSM</sub>	Non Repetitive Peak Reverse Current	t <sub>p</sub> = 100 μs	1	A
dv/dt	Critical Rate Of Rise Of Reverse Voltage		10000	V/μs

**Table 5: Thermal Data**

R <sub>thj-case</sub>	Thermal Resistance Junction-case Single Operating	50	°C/W
R <sub>thj-amb</sub>	(*)Thermal Resistance Junction-ambient SCHOTTKY	100	°C/W
T <sub>l</sub>	Maximum Lead Temperature For Soldering Purpose	300	°C

(\*) Mounted on FR-4 board (Steady State)

**ELECTRICAL CHARACTERISTICS (T<sub>CASE</sub> =25°C UNLESS OTHERWISE SPECIFIED)**

**Table 6: On/Off**

Symbol	Parameter	Test Conditions	Min.	Typ.	Max	Unit
V <sub>(BR)DSS</sub>	Drain-source Breakdown Voltage	I <sub>D</sub> = 250 μA, V <sub>GS</sub> = 0	30			V
I <sub>DSS</sub>	Zero Gate Voltage Drain Current (V <sub>GS</sub> = 0)	V <sub>DS</sub> = Max Rating V <sub>DS</sub> = Max Rating, T <sub>C</sub> = 125°C			1 10	μA μA
I <sub>GSS</sub>	Gate-body Leakage Current (V <sub>DS</sub> = 0)	V <sub>GS</sub> = ± 16V			±100	nA
V <sub>GS(th)</sub>	Gate Threshold Voltage	V <sub>DS</sub> = V <sub>GS</sub> , I <sub>D</sub> = 250 μA	1	1.6	2.5	V
R <sub>DS(on)</sub>	Static Drain-source On Resistance	V <sub>GS</sub> = 10 V, I <sub>D</sub> = 2.5 A V <sub>GS</sub> = 4.5 V, I <sub>D</sub> = 2.5 A		0.045 0.065	0.055 0.075	Ω Ω

## ELECTRICAL CHARACTERISTICS(CONTINUED)

Table 7: Dynamic

Symbol	Parameter	Test Conditions	Min.	Typ.	Max.	Unit
$g_{fs}$ (1)	Forward Transconductance	$V_{DS} = 15\text{ V}$ , $I_D = 2.5\text{ A}$		10		S
$C_{iss}$	Input Capacitance	$V_{DS} = 25\text{ V}$ , $f = 1\text{ MHz}$ , $V_{GS} = 0$		1350		pF
$C_{oss}$	Output Capacitance			490		pF
$C_{rss}$	Reverse Transfer Capacitance			130		pF

(1) Pulsed: Pulse duration = 300  $\mu\text{s}$ , duty cycle 1.5%

Table 8: Switching On

Symbol	Parameter	Test Conditions	Min.	Typ.	Max.	Unit
$t_{d(on)}$ $t_r$	Turn-on Delay Time Rise Time	$V_{DD} = 15\text{ V}$ , $I_D = 2.5\text{ A}$ , $R_G = 4.7\ \Omega$ , $V_{GS} = 4.5\text{ V}$ (see Figure 16))		25 35		ns ns
$Q_g$ $Q_{gs}$ $Q_{gd}$	Total Gate Charge Gate-Source Charge Gate-Drain Charge	$V_{DD} = 24\text{ V}$ , $I_D = 5\text{ A}$ , $V_{GS} = 5\text{ V}$ (see, Figure 19)		12.5 5 3	16	nC nC nC

Table 9: Switching Off

Symbol	Parameter	Test Conditions	Min.	Typ.	Max.	Unit
$t_{d(off)}$ $t_f$	Turn-off Delay Time Fall Time	$V_{DD} = 15\text{ V}$ , $I_D = 2.5\text{ A}$ , $R_G = 4.7\ \Omega$ , $V_{GS} = 4.5\text{ V}$ (see, Figure 16)		125 35		ns ns

Table 10: Source-Drain Diode

Symbol	Parameter	Test Conditions	Min.	Typ.	Max.	Unit
$I_{SD}$	Source-drain Current				5	A
$I_{SDM}$ (2)	Source-drain Current (pulsed)				20	A
$V_{SD}$ (1)	Forward On Voltage	$I_{SD} = 5\text{ A}$ , $V_{GS} = 0$			1.2	V
$t_{rr}$ $Q_{rr}$ $I_{RRM}$	Reverse Recovery Time Reverse Recovery Charge Reverse Recovery Current	$I_{SD} = 5\text{ A}$ , $di/dt = 100\text{ A}/\mu\text{s}$ $V_{DD} = 15\text{ V}$ , $T_j = 150^\circ\text{C}$ (see, Figure 17)		45 36 1.6		ns nC A

Table 11: Schottcky Static Electrical Characteristics

Symbol	Parameter	Test Conditions	Min.	Typ.	Max.	Unit
$I_R$ (*)	Reversed Leakage Current	$T_J = 25^\circ\text{C}$ , $V_R = 30\text{ V}$ $T_J = 125^\circ\text{C}$ , $V_R = 30\text{ V}$		0.03	0.2 100	mA mA
$V_F$ (*)	Forward Voltage Drop	$T_J = 25^\circ\text{C}$ , $I_F = 3\text{ A}$ $T_J = 125^\circ\text{C}$ , $I_F = 3\text{ A}$		0.46	0.51 0.46	V V

(1) Pulsed: Pulse duration = 300  $\mu\text{s}$ , duty cycle 1.5 %.

(2) Pulse width limited by safe operating area.

Figure 3: Safe Operating

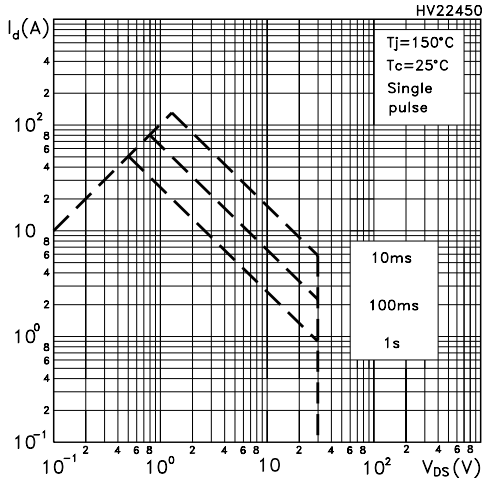

Figure 4: Output Characteristics

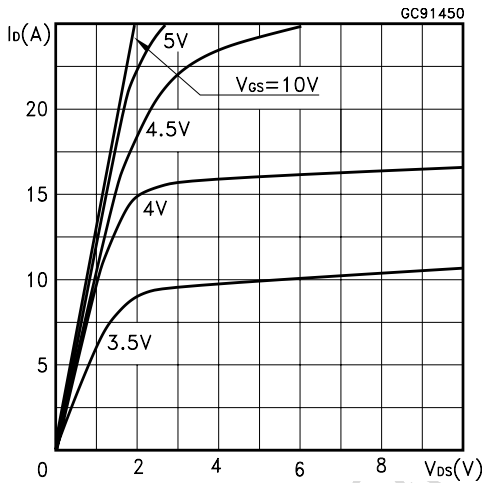

Figure 5: Transconductance

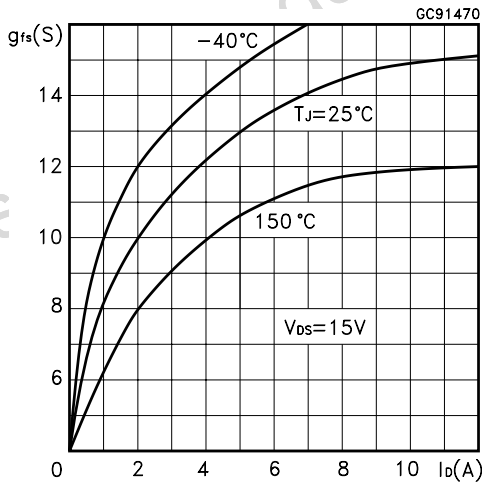

Figure 6: Thermal Impedance

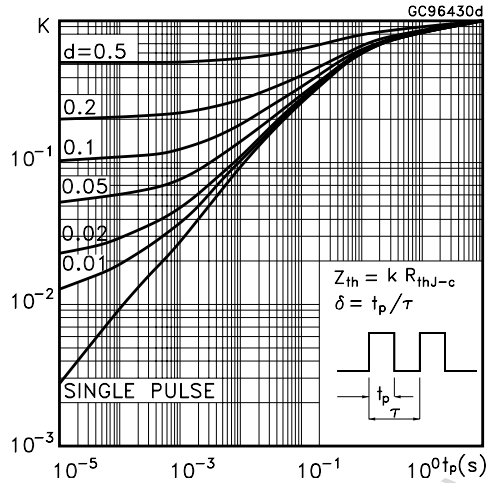

Figure 7: Transfer Characteristics

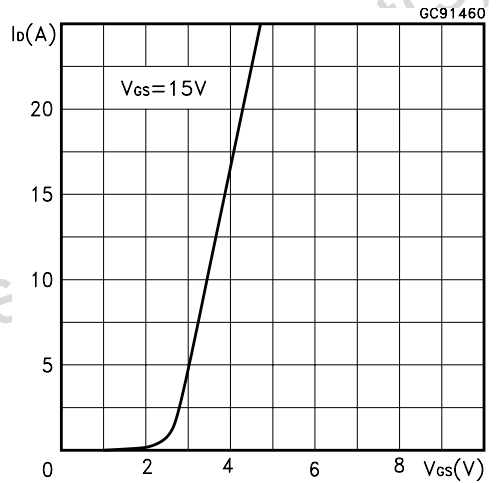

Figure 8: Static Drain-Source On Resistance

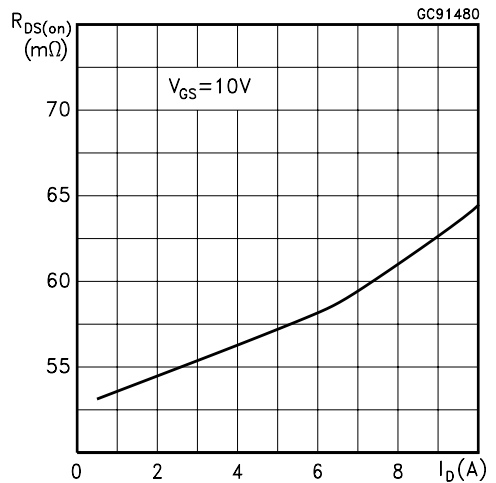

Figure 9: Gate Charge vs Gate-Source Voltage

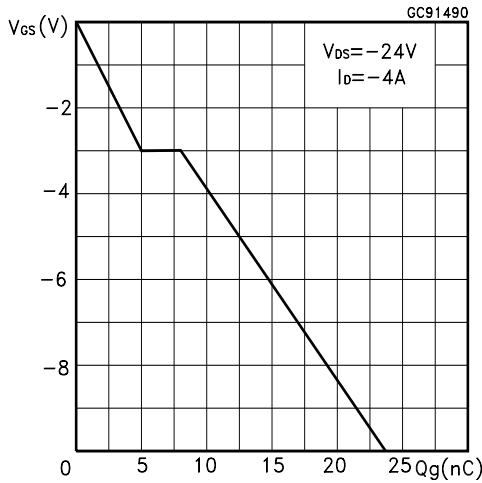

Figure 10: Normalized Gate Threshold Voltage vs Temperature

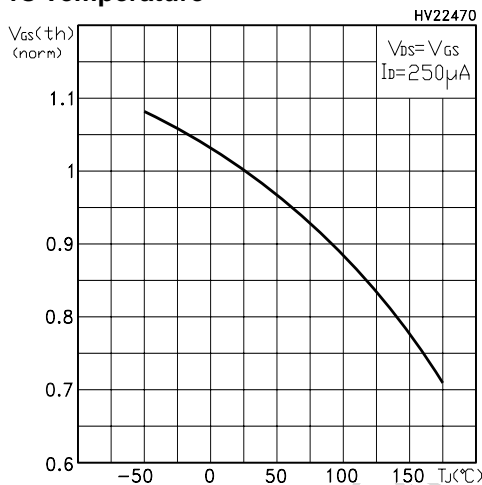

Figure 11: Source-Drain Diode Forward Characteristics

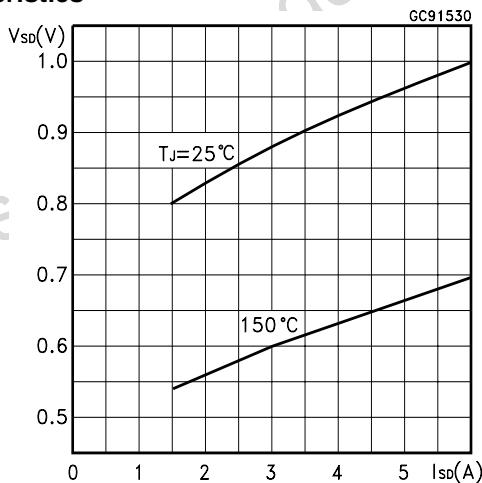

Figure 12: Capacitance Variations

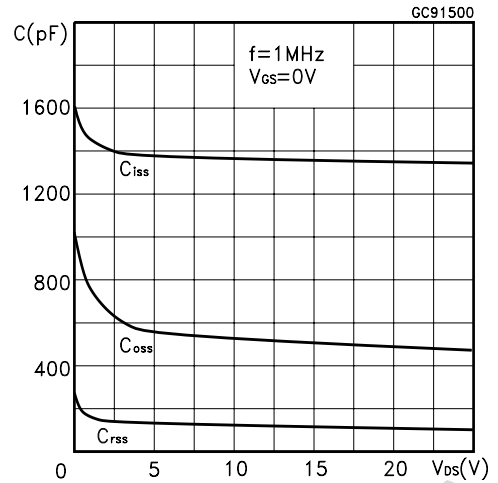

Figure 13: Normalized On Resistance vs Temperature

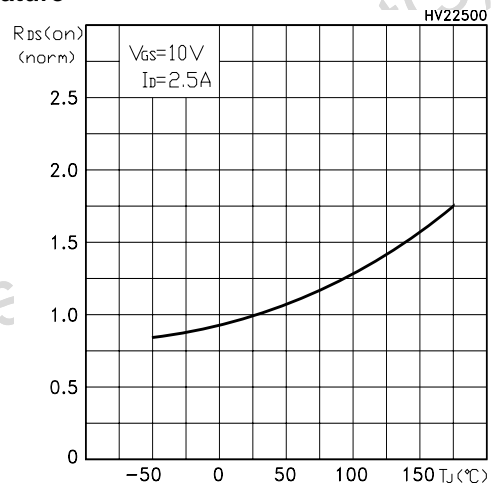

Figure 14: Normalized BVds vs Temperature

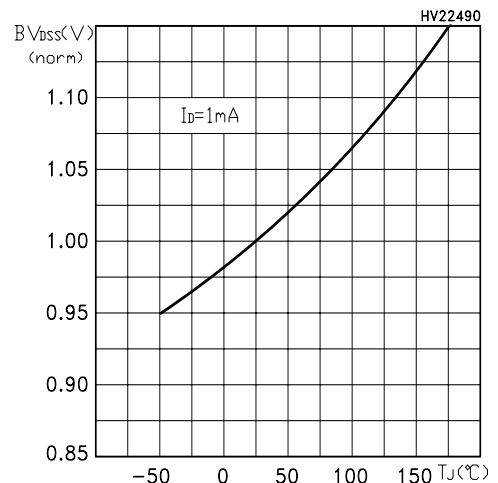

Figure 15: Unclamped Inductive Load Test Circuit

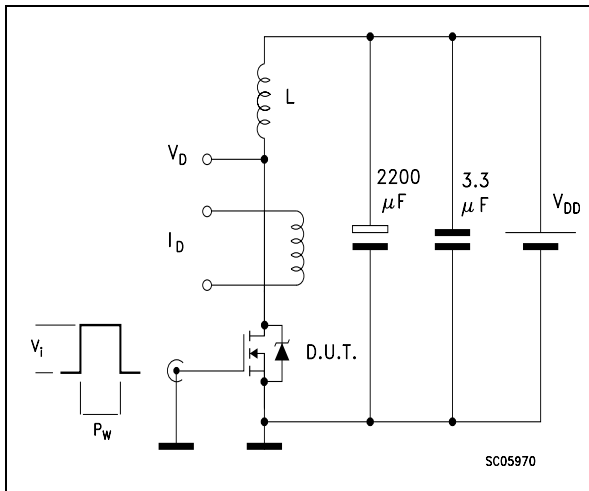

Figure 16: Switching Times Test Circuit For Resistive Load

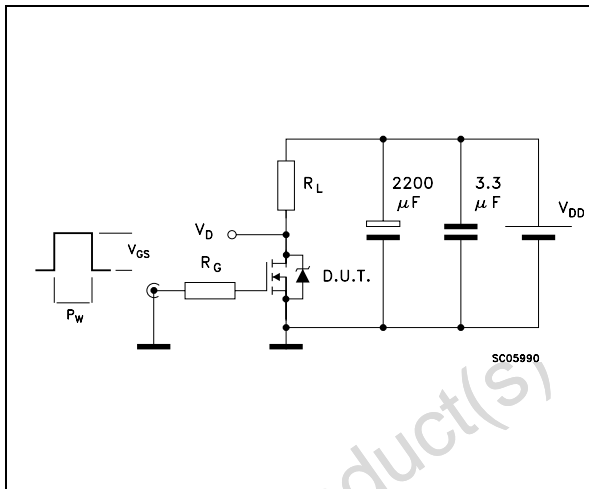

Figure 17: Test Circuit For Inductive Load Switching and Diode Recovery Times

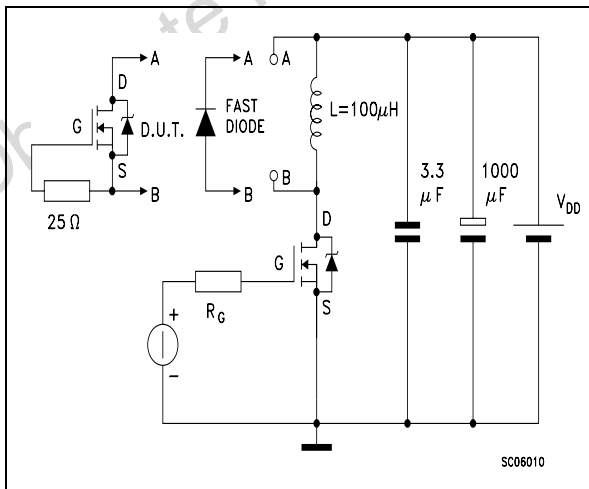

Figure 18: Unclamped Inductive Wafemr

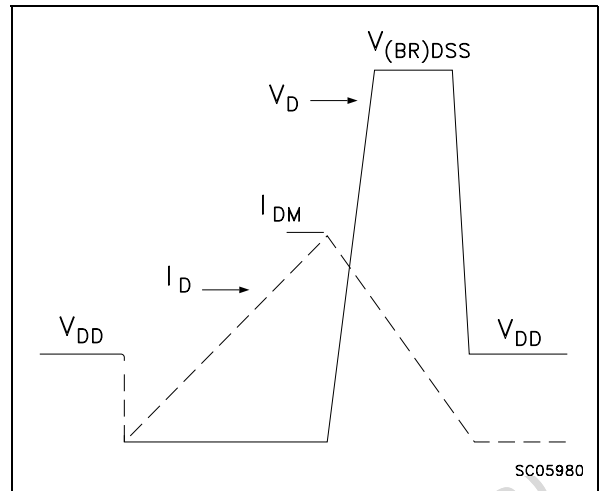
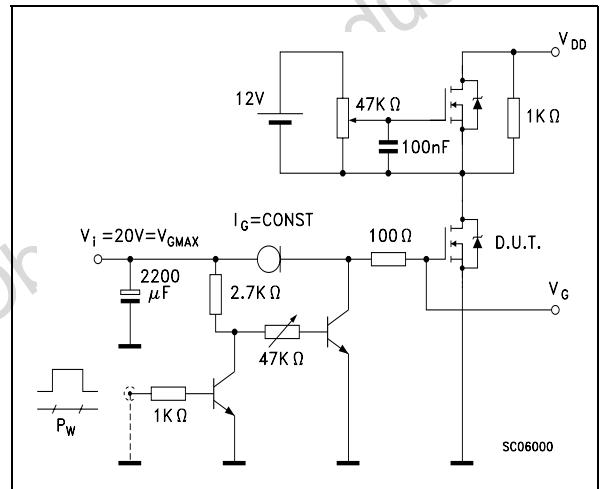

Figure 19: Gate Charge Test Circuit



**SO-8 MECHANICAL DATA**

DIM.	mm.			inch		
	MIN.	TYP.	MAX.	MIN.	TYP.	MAX.
A			1.75			0.068
a1	0.1		0.25	0.003		0.009
a2			1.65			0.064
a3	0.65		0.85	0.025		0.033
b	0.35		0.48	0.013		0.018
b1	0.19		0.25	0.007		0.010
C	0.25		0.5	0.010		0.019
c1	45 (typ.)					
D	4.8		5.0	0.188		0.196
E	5.8		6.2	0.228		0.244
e		1.27			0.050	
e3		3.81			0.150	
F	3.8		4.0	0.14		0.157
L	0.4		1.27	0.015		0.050
M			0.6			0.023
S	8 (max.)					

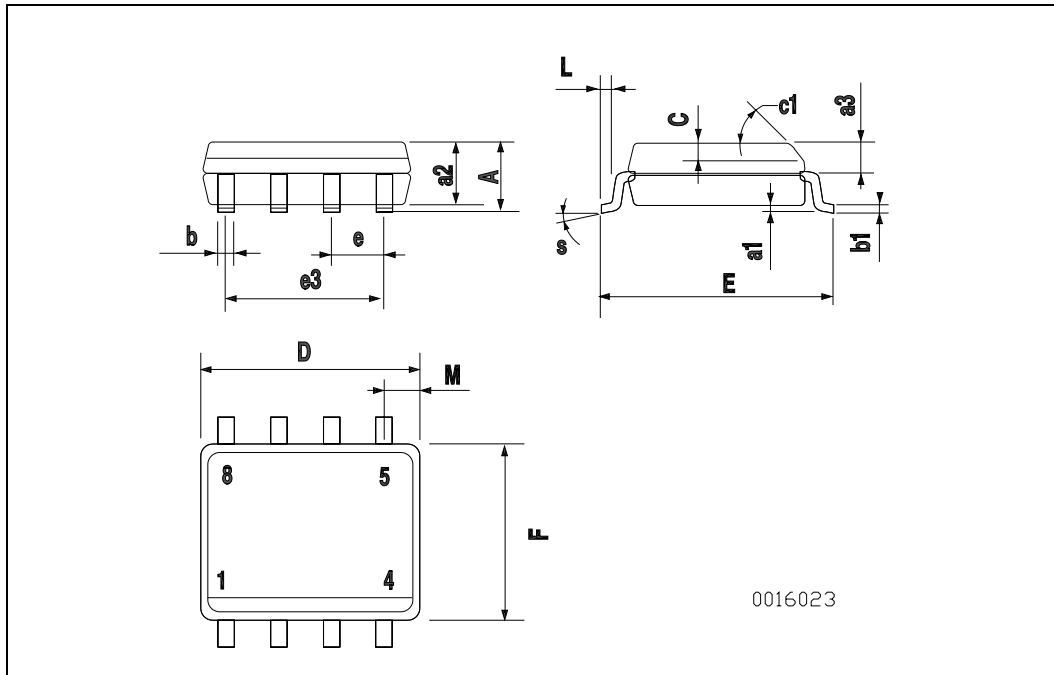

Table 12: Revision History

Date	Revision	Description of Changes
14-Dec-2004	1	First Revision

Obsolete Product(s) - Obsolete Product(s)



Information furnished is believed to be accurate and reliable. However, STMicroelectronics assumes no responsibility for the consequences of use of such information nor for any infringement of patents or other rights of third parties which may result from its use. No license is granted by implication or otherwise under any patent or patent rights of STMicroelectronics. Specifications mentioned in this publication are subject to change without notice. This publication supersedes and replaces all information previously supplied. STMicroelectronics products are not authorized for use as critical components in life support devices or systems without express written approval of STMicroelectronics.

The ST logo is a registered trademark of STMicroelectronics

All other names are the property of their respective owners

© 2004 STMicroelectronics - All Rights Reserved

STMicroelectronics group of companies

Australia - Belgium - Brazil - Canada - China - Czech Republic - Finland - France - Germany - Hong Kong - India - Israel - Italy - Japan - Malaysia - Malta - Morocco - Singapore - Spain - Sweden - Switzerland - United Kingdom - United States of America