

CTH 46 - CTD 43 / 46 CTD 46 Part number 89422118



- CTH 46
- Heating / cooling function
 - Measurement and setpoint display
- CTD 43
- Heating or cooling function
 - Measurement display
 - Measurement deviation display-Setpoint via LED
 - 1 configurable alarm
- CTD 46
- Heating or cooling function
 - Measurement and setpoint display
 - 1 configurable alarm

Part numbers

	Type	Output	Supply voltage
89422118	CTD 46	Logic	100 →240 V AC

Specifications

General characteristics

Supply	100 to 240 VAC, 24 VACDC
Frequency (Hz)	50 / 60
Tolerance	-15 % +10 % Un
Consumption	8 VA max.
Display measurement	red LEDs-4 digits, 7 segment, height 10 mm
Display setpoint	green LEDs-4 digits, 7 segment, height 7,5 mm

Control characteristics

Control algorithm	PID with auto-tune and adaptive tune : SMART
Control type	heat or cool heat / cool
Sampling time linear input	250 ms
Sampling time TC and RTD input	500 ms
Proportional band Pb heat or cool	1,0 to 100 % of scale amplitude
Proportional band Pb heat - cool	1,5 to 100 % of scale amplitude
Proportional band Pb Note : if Pb = 0 % discrete action	■
Hysteresis (during discrete action)	0,1 to 10 % of scale amplitude
Integral time ti Note : if ti > 20 min integral action is inactive	20 s to 20 min
Derivative time td. Note : if td=0 derivative action is inactive	1 s to 10 min
Cycle time heating	1 s →200 s
Cycle time cooling	1 s →200 s
Heat-cool control Cool proportional band	rC x heat proportional band
Heat-cool control rC : relative gain	0,20 →1,00
Heat-cool control dead.overlap band	-20 % to + 50 % of the heat proportional band

Inputs

Thermocouples J, K, R, S, and N	IEC 584-1
Thermocouples L	DIN 43710
Reference junction	Automatic cold junction compensation : 0 to 50 °C (Thermocouples)
Reference junction drift	0,1 °C / °C
Input impedance (kΩ)	> 1 M Ω
Calibration (IEC 584-1)	■
Resist. temp. detector 3-wire Pt 100 conforming to DIN 43760	■
Line resistance	20 Ω max. (Resistance temperature detector)
Input type and standard range TC	L (0/400 °C) (0/1650°F) (0/900 °C) J (0/400 °C) (0/1830°F) (0/1000 °C) K (0/400 °C) (0/2190°F) (0/1200 °C) N (0/1400 °C) (0/2550°F) R (0/1760 °C) (0/3200°F) S (0/1760 °C) (0/3200°F)
Input types and standard rangeRTD Pt100	(-199,9/400,0 °C) (-199,9/400,0°F) (-200/800 °C) (-330/1470°F)

Measurement range	- 1999 →+ 4000
Decimal point	adjustable : - - - - , - - - - , - - - - , - - - -

Current transformer input for monitoring the load break

Inputs	50 mAAC
Measurement range with transformer	10 A →100 A
Resolution	10 to 20 A : 0.1 A 21 to 100 A : 1 A
Measurement logic threshold	Relay output : NO or NC Logic output : level 1 or 0
Measurement update period	50 ms
Setpoints	- main setpoint : SP - auxiliary setpoint : SP2
Selection input SP/SP2	50 mA AC selection via external N/C type contact

Output

Type of output	discontinuous
Action type	can be programmed for heating and/or cooling
Limitation of output power : SOFT-START- heat action	adjustable from 0 to 100 %
Limitation of output power : SOFT-START-heat/cool action	adjustable from -100 to +100 %

Output specification

OUT 1 Main output N/O contact	3A 250 V AC resistive (N/C contact is possible via a jumper)
OUT 1 Main output logic	Level 0 : <0,5 V DC Level 1 : 14 V DC±20 % @ 20 mA max 24 V DC±20 % @ 1 mA max
Main output cycle time	1 s →99 s
OUT 2 Cool output or alarm 1 output	N/O-2A contact, 250 V AC resistive
OUT 3 Load break output and/or alarm 2 output	N/O-2A contact, 250 V AC resistive

Description of alarms 1 and 2

Type of output	direct or reverse
Functions	absolute alarm band alarm deviation alarm
Reset to zero	Manual / automatic
Inhibition	Configuration
Alarm threshold - absolute alarm	absolute value independent from SP
Alarm threshold - band alarm	value relative to SP, adjustable from 0 to 500 °C/°F
Alarm threshold - deviation alarm	value relative to SP, adjustable from -500 °C/°F (negative deviation) to + 500 °C/°F (positive deviation)
Alarm	0.1 to 10 % of scale amplitude

Serial link

Type	RS485
Protocol	MODBUS, J.BUS
Address	1 →255
Number of data bits	8
Transmission speed	600 →19 200 Bauds
Parity	even, odd, no
Stop bit	1

Physical details and protection

Insulation resistance conforming to IEC 348	> 100 MΩ
Insulation voltage according to IEC 348	1500 V
Immunity to interference conforming to IEC 801-4	Level 3
Immunity to interference conforming to IEC 801-2	8000 V
Accuracy	± 0.2 % of the full measurement scale ± 1 digit at an ambient temperature of 25 °C at Un
Operating temperature range (°C)	0 →+50
Storage temperature range (°C)	-20 →+70 °C
Relative humidity (no condensation)	20 →85 % Rh

Housing

Housing material	self-extinguishing UL94 grade VO
Front panel	Polycarbonate membrane
Protection class according to IEC 529 (IEC 70-1)	IP 54
Connection	screw terminals
Weight (g)	250

Approvals

UL / CSA	in progress
----------	-------------

Protection

Safe-guard	detects a fault in the equipment caused by external interference and activates automatic reset without modification of the process.
Switch	the configuration and calibration are accessed via an internal switch, can only be accessed when the device is unplugged.

Supply	100 to 240 VAC
Frequency (Hz)	50 / 60
Tolerance	-15 % +10 % Un
Consumption	5 VA

Display CTD 43	Measurement or setpoint : red LEDs, 3-digit, 7-segment, height 10 mm
Display CTH 47 / CTD 46	Measurement : red LEDs, 3-digit, 7-segment, height 10 mm Setpoint : green LEDs, 3-digit, 7-segment, height 7,5 mm
Switch	the configuration and calibration are accessed via an internal switch, which can only be accessed when the equipment is disconnected
Insulation resistance conforming to IEC 348	> 100 MΩ
Insulation voltage according to IEC 348	1500 V
Immunity to interference conforming to IEC 801-4	Level 3
Immunity to interference conforming to IEC 801-2	8000 V
Accuracy	± 0.3 % of the full measurement scale at an ambient temperature of 25 °C at Un
Operating temperature range (°C)	0 →+50 °C
Storage temperature range (°C)	-30 →+70 °C
Relative humidity (Rh no condensation)	20 →85 %
Housing material	self-extinguishing UL94 VO grade
Front panel	polycarbonate membrane
Protection class according to IEC 529 (IEC 70-1)	IP 54
Connection	screw terminals
Weight (g)	160
Approvals	UL/CSA

Inputs

Thermocouples J, K, and N	IEC 584-1
Thermocouples L	DIN 43710
Reference junction	Automatic cold junction compensation : 0 to 50 °C (Thermocouples)
Reference junction drift	0,1 °C / °C
Line resistance	100 Ω max
Calibration (IEC 584-1)	IEC 584 - 1
Resist. temp. detector Pt 100 according to IEC 751	3-wire
Line resistance	< 4 Ω
Input type and standard range TC	L (0/800 °C) (0/999°F) J (0/800 °C) (0/999°F) K (0/999 °C) (0/999°F) N (0/999 °C) (0/999°F)
Input types and standard rangeRTD Pt100	(-199/500 °C) (-19,9/99,9°F) (-199/999 °C)

Output

Type of output	discontinuous
Action type CTH 46	heating-cooling
Action type CTD 43 - CTD 46	heating or cooling
Limitation of output power : SOFT-START- heat action	adjustable from 0 to 100 %
Limitation of output power : SOFT-START-heat/cool action	adjustable from -100 to + 100 %
Main output changeover relay	3 A 250 V AC resistive
Main output--logic	Max. load : 700 Ω Level 0 : < 0,5 V DC Level 1 : 14 V DC± 20 % @ 20 mA max 24 V DC± 20 % @ 1 mA max
Main output cycle time	1 s →200 s
Cool output CTH 46 only	N/O-1 A contact, 250 V AC resistive
Alarm output CTD 43-CTD 46 only	N/O-1 A contact, 250 V AC resistive

Control characteristics

Control algorithm	PID with auto-tune and adaptive tune : SMART
Control type CTD 43 CTD 46	heating or cooling
Control type CTH 46	heating-cooling
Sampling time	500 ms
Proportional band Pb CTD 43 - CTD 46	1,0 % to 99,9 % of scale amplitude
Proportional band Pb CTH 46	1,5 % to 99,9 % of scale amplitude
Proportional band Pb Note : if Pb = 0 % discrete action	■
Hysteresis (during discrete action)	0,1 % to 10 % of scale amplitude
Integral time ti Note : if ti > 20 min	1 min 20 s to 20 min 0 s (10 s resolution)
Derivative time td. Note : if td=0	1 s to 9 min 59 s
Cycle time heating	1 s →200 s
Cycle time cooling (CTH46 only)	1 s →200 s
Heat-cool control CTH 46 Cool proportional band	rC x heat proportional band
Heat-cool control rC : relative gain	0,20 →1,00
Heat-cool control CTH 46 dead.overlap band	-20 % to + 50 % of the heat proportional band

Alarms (on CTD 43 and CTD 46 only)

Type of output	direct or reverse
Functions	absolute alarm band alarm deviation alarm
Reset to zero	manual

Inhibition	can be configured
Alarm threshold - absolute alarm	absolute value independent from SP
Alarm threshold - band alarm	value relative to SP, adjustable from 0 to 500 °C/°F
Alarm threshold - deviation alarm	value relative to SP, adjustable from -199 °C/°F (negative deviation) to +500 °C/°F (positive deviation)
Alarm	0.1 to 10 % of scale amplitude

Dimensions (mm)

CTH/CTD

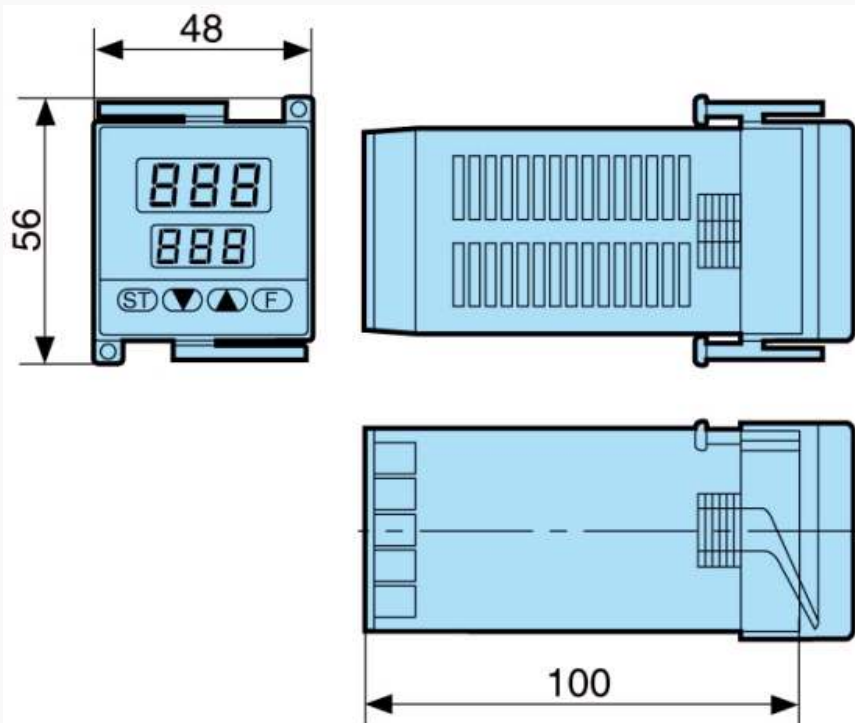

Dimensions (mm)

Panel cut-out

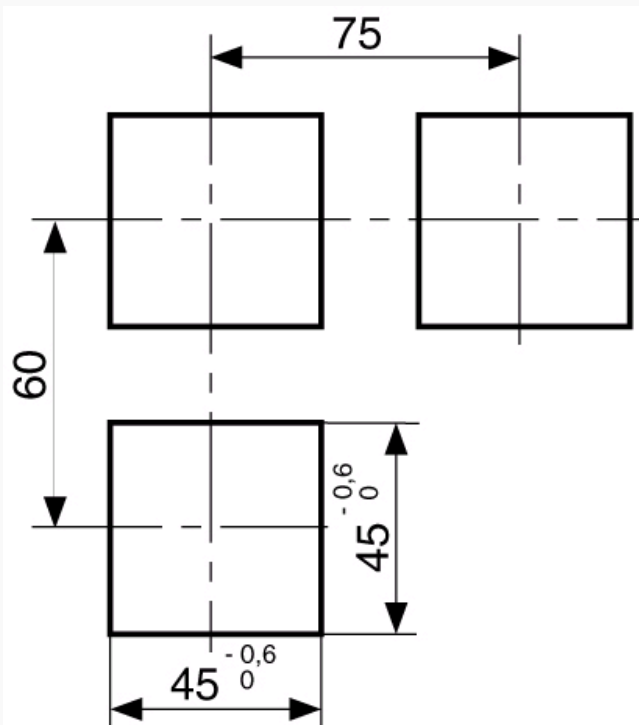

Panel cut-out

Curves

Modes de fonctionnement

Résumé des différentes configurations

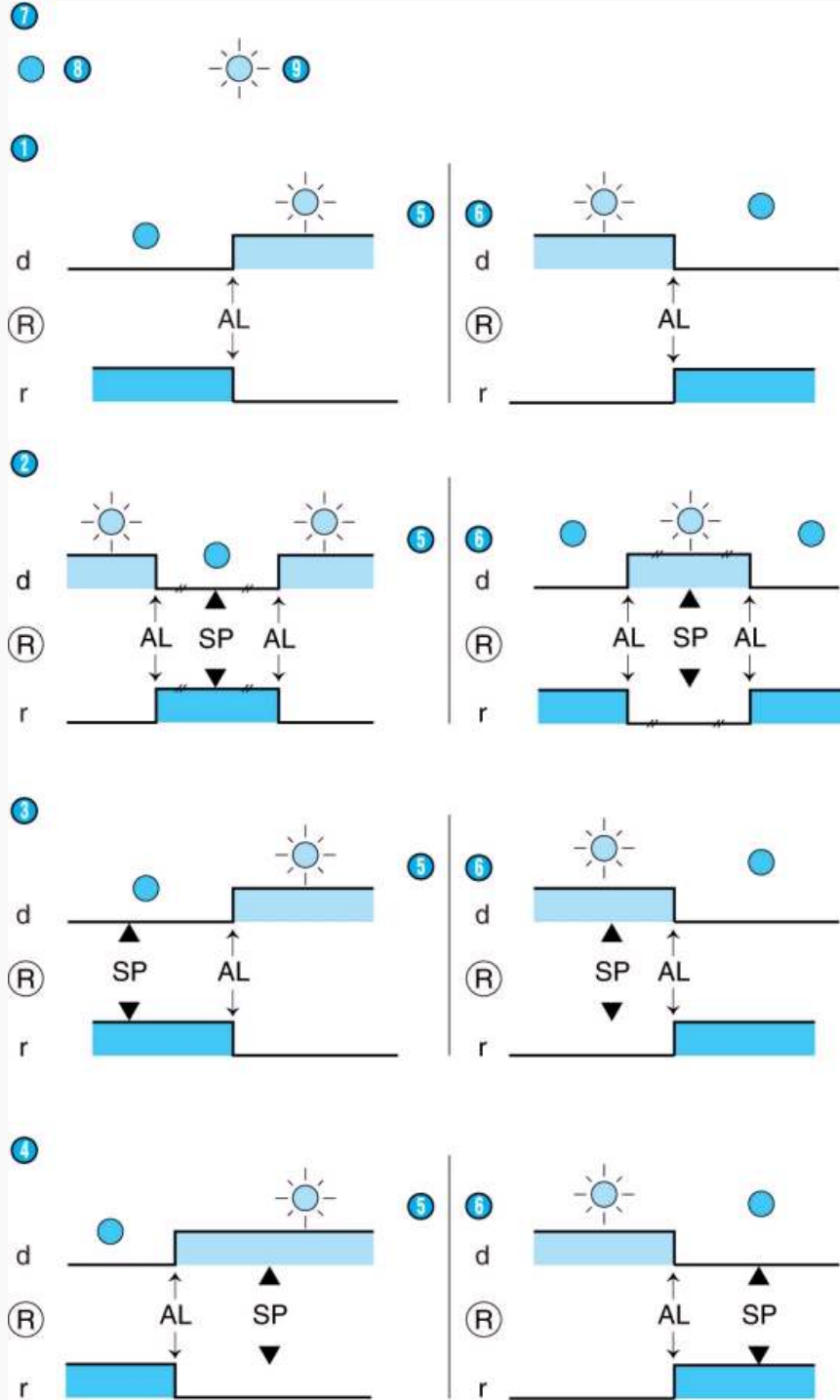

N°	Legend
1	Absolute alarm
2	Band alarm
3	Positive deviation alarm
4	Negative deviation alarm
5	High
6	Low

Connections
CTD 46 relay output

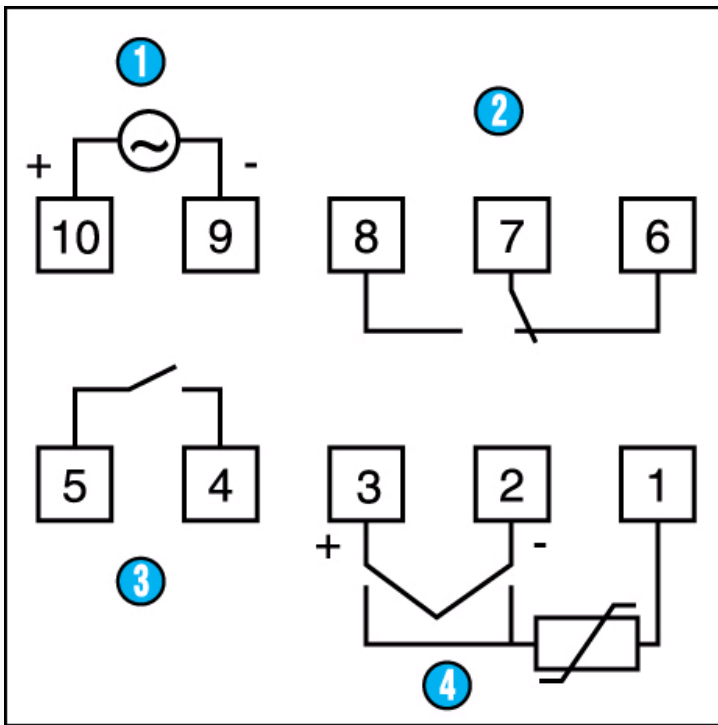

N°	Legend
1	Supply
2	Main output 250 V AC / 3 A
3	Alarm output 250 V AC / 1 A
4	14-15 : Input 50 mA AC (Current transformer connected for load break monitoring or selection of 2 nd setpoint)

Connections

CTD 46 logic output

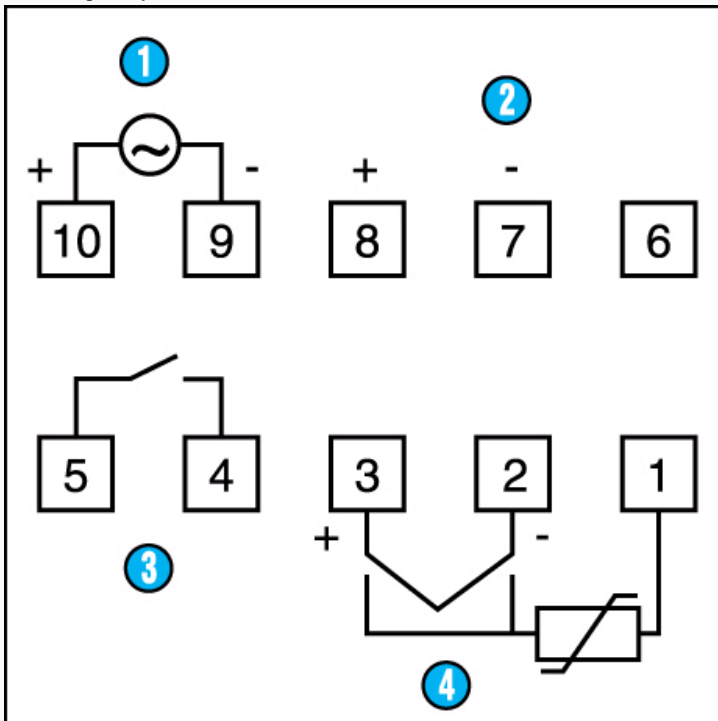

N°	Legend
1	Supply
2	Main output 0-24 V DC / 20 mA max

?	Alarm output 250 V AC / 1 A
?	14-15 : Input 50 mA AC (Current transformer connected for load break monitoring or selection of 2 nd setpoint)