

THIS DRAWING IS UNPUBLISHED. RELEASED FOR PUBLICATION
 © COPYRIGHT 19 BY AMP INCORPORATED. ALL RIGHTS RESERVED.

LOC	DIST	REVISIONS			
P	LTR	DESCRIPTION	DATE	DWN	APVD
BD	36	E	REDRAWN PER EC 0020-1245-95	01 NOV 95	-

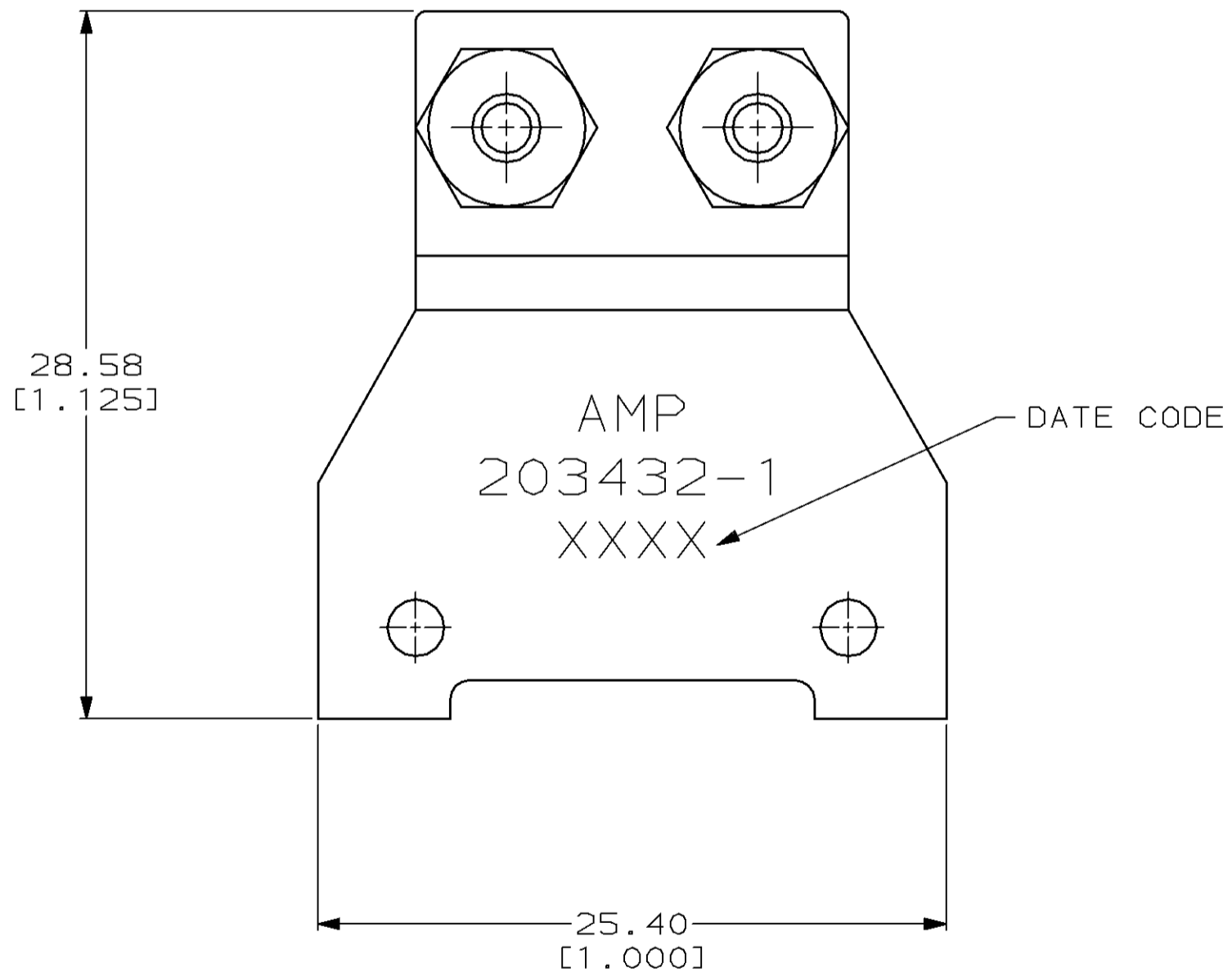
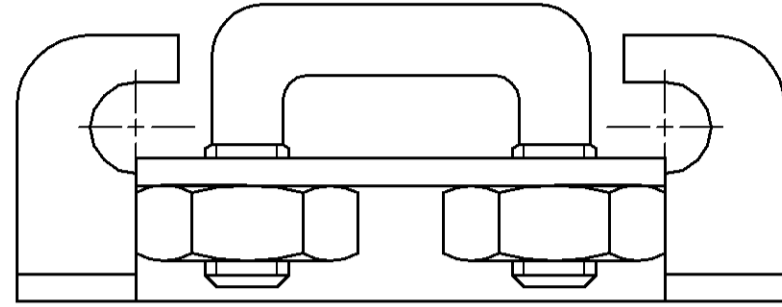

ASSEMBLED VIEW

4-40UNC HEX NUT
2 EA

U BOLT

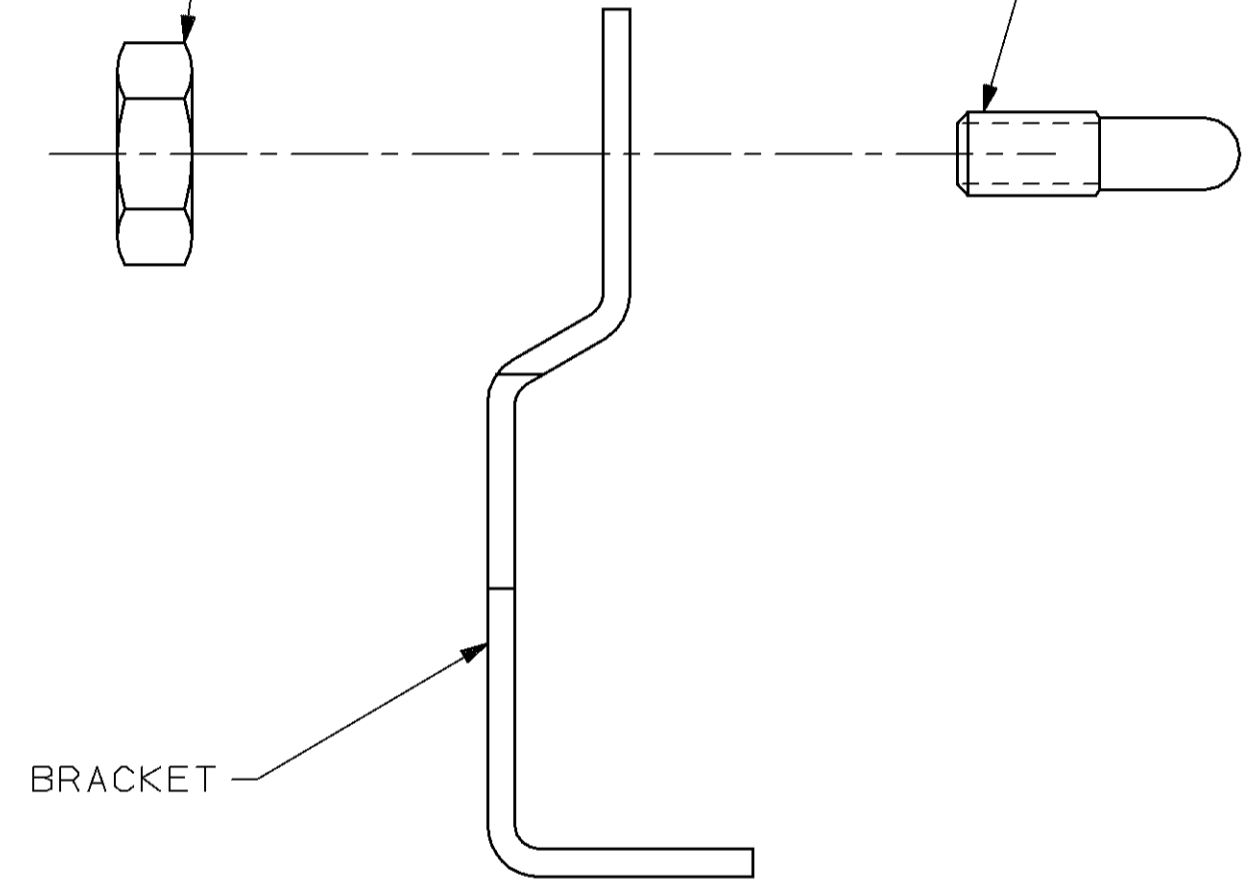

- ① BRACKET & HEX NUTS: CARBON STEEL.
U BOLT: STAINLESS STEEL.
- ② BRACKET: 5.08µm [0.000200] MIN NICKEL.
HEX NUTS: ZINC PLATED.
U BOLT: PASSIVATED.

203432-1

PART NUMBER

<small>THIS DRAWING IS A CONTROLLED DOCUMENT FOR AMP INCORPORATED. IT IS SUBJECT TO CHANGE AND THE CONTROLLING ENGINEERING ORGANIZATION SHOULD BE CONTACTED FOR THE LATEST REVISION.</small>		DWN C. REIFSNYDER 01 NOV 95 CHK R. STONE 17 NOV 95 APVD G. STEINHAUER 19 NOV 95	AMP AMP Incorporated Harrisburg, PA 17105-3608
DIMENSIONS: mm [INCHES]	TOLERANCES UNLESS OTHERWISE SPECIFIED: 0 PLC ±- 1 PLC ±- 2 PLC ±0.51 [0.020] 3 PLC ±- 4 PLC ±- ANGLES ±- FINISH	NAME CLAMP KIT, UNASSEMBLED, STRAIN RELIEF, 6 POSITION, M SERIES PRODUCT SPEC - APPLICATION SPEC - WEIGHT -	SIZE A2 CAGE CODE 00779 DRAWING NO C-203432
MATERIAL ①	FINISH ②	CUSTOMER DRAWING	SCALE 4:1 SHEET 1 OF 1 REV E

203432

A