

## Low Power Networking Clock Generator

### Features

- 25 MHz crystal or clock input
- Three differential 100 MHz PCI-Express clock outputs – push-pull termination
- Spread spectrum capability on all 100 MHz PCI-e clock outputs with -0.5% down spread
- One single-ended 66.66 MHz output
- One single-ended 125 MHz output for Gigabit Ethernet at 2.5V
- One single-ended 80 MHz output with selectable down spread.
- 40-pin QFN package
- Operating voltage 3.3 V ±5%
- Industrial temperature (-40 to +85°C)

### Description

The PI6C49016 is a clock generator device intended for PCI-Express/networking applications. The device includes three 100 MHz differential outputs for PCI-Express using reduced power, one single-ended 125 MHz output, one single-ended 66.66 MHz, and one single-ended 80 MHz output with spread spectrum.

Using a serially programmable SMBus interface, the PI6C49016 incorporates spread spectrum modulation on the four 100 MHz PCI-Express outputs with -0.5% down spread and the 80 MHz output with selectable down spread.

### Block Diagram

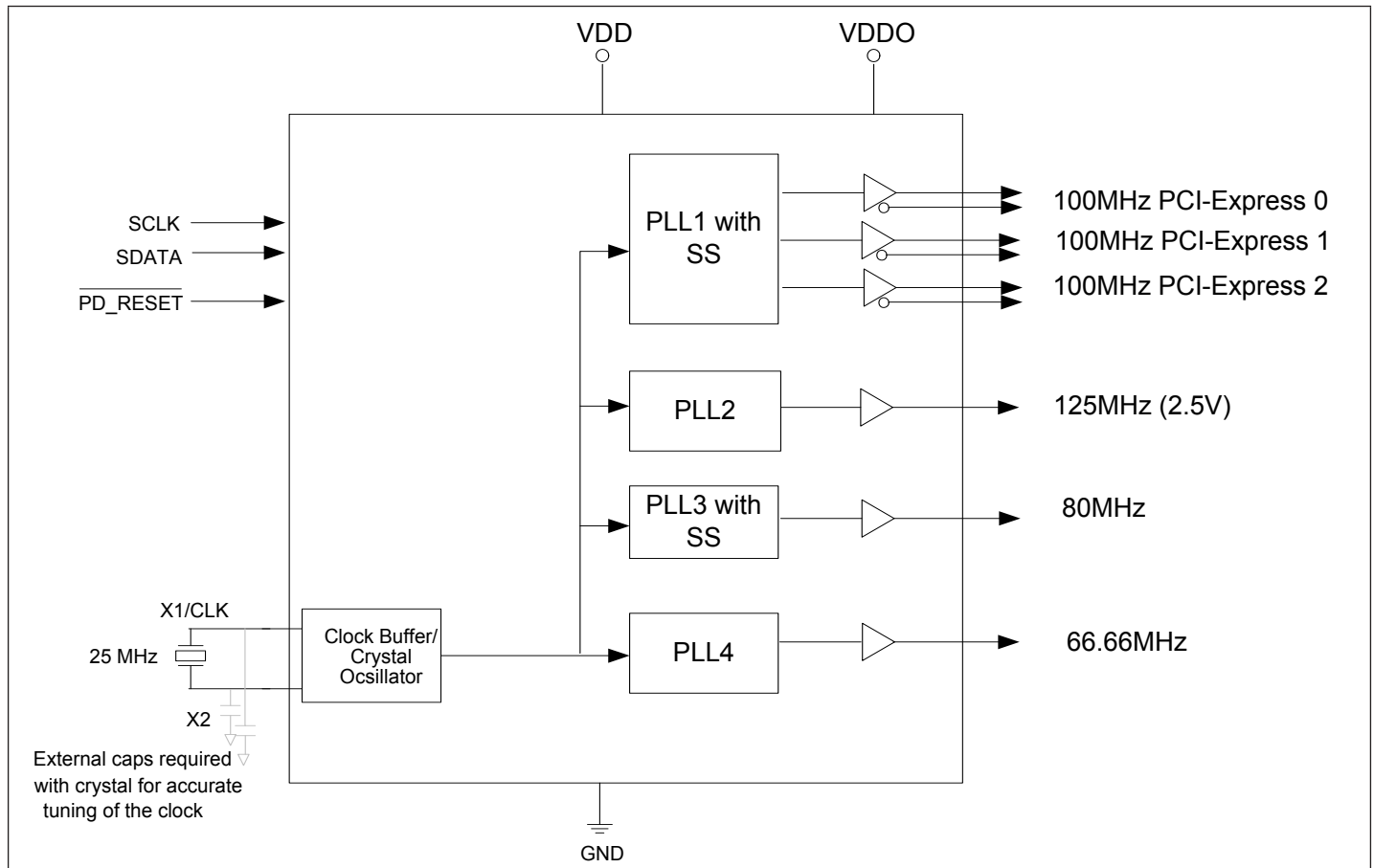

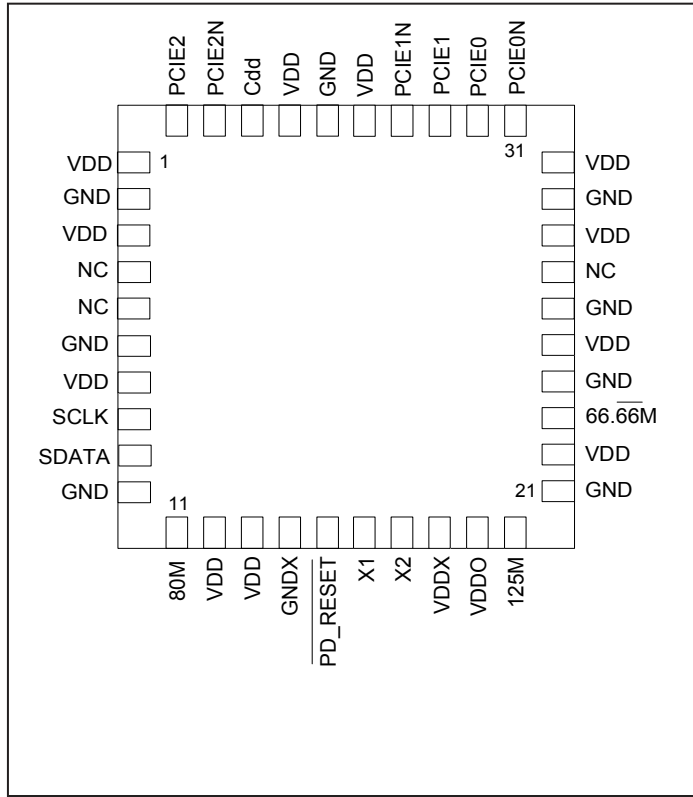
**Pin Description**

**Power Grouping**

Pins	Group Description
1, 3, 7, 30	Power for PCIe clocks
12	Power for 80 MHz PLL and output
13, 22, 28	Power for 60/66 MHz PLL and outputs
18	Power for crystal oscillator
19	Output Power for 125 MHz
25	Power for 125 MHz PLL
35, 37	Digital power

**Pin List**

Pin#	Pin Name	Pin Type	Pin Description
1	VDD	Power	3.3V Supply Pin
2	GND	Power	Ground
3	VDD	Power	3.3V Supply Pin
4	NC	-	-
5	NC	-	-
6	GND	Power	Ground
7	VDD	Power	3.3V Supply Pin
8	SCLK	Input	SMBus clock input
9	SDATA	I/O	SMBus data input
10	GND	Power	Ground
11	80M	Output	80 MHz LVCMOS output. Tri-state with weak pull-down when disabled
12	VDD	Power	3.3V Supply Pin
13	VDD	Power	3.3V Supply Pin
14	GNDX	Power	Ground
15	$\overline{\text{PD\_RESET}}$	Input	Global reset input powers down PLLs plus tri-states outputs and sets the I2C tables to their default state when pulled low. Controlled by external POR

## Pin List

Pin#	Pin Name	Pin Type	Pin Description
16	X1	XI	Crystal input. Connect to 25 MHz fundamental mode crystal or clock
17	X2	XO	Crystal output. Connect to 25 MHz fundamental mode crystal. Float for clock input
18	VDDX	Power	3.3V Supply Pin
19	VDDO	Power	125 MHz output supply voltage. Connect to +2.5 V.
20	125M	Output	125 MHz, +2.5 V LVCMOS output. Tri-stated with a weak pull-down when disabled.
21	GND	Power	Ground
22	VDD	Power	3.3V Supply Pin
23	66.66M	Output	66.66 MHz LVCMOS output. Tri-stated with a weak pull-down when disabled
24	GND	Power	Ground
25	VDD	Power	3.3V Supply Pin
26	GND	Power	Ground
27	NC	-	-
28	VDD	Power	3.3V Supply Pin
29	GND	Power	Ground
30	VDD	Power	3.3V Supply Pin
31	PCIE0N	Output	Differential 100 MHz PCI Express Clock output
32	PCIE0	Output	Differential 100 MHz PCI Express Clock output
33	PCIE1	Output	Differential 100 MHz PCI Express Clock output
34	PCIE1N	Output	Differential 100 MHz PCI Express Clock output
35	VDD	Power	3.3V Supply Pin
36	GND	Power	Ground
37	VDD	Power	3.3V Supply Pin
38	Cdd	Input	Input pin for off chip bypass capacitor. Connect to 0.01 $\mu$ F capacitor
39	PCIE2N	Output	Differential 100 MHz PCI Express Clock output
40	PCIE2	Output	Differential 100 MHz PCI Express Clock output

Notes: VDD and GND Pins Layout Guide

1. Small value decoupling caps. (0.1 $\mu$ F, 1 $\mu$ F, and 2.2 $\mu$ F) should be placed close each VDD pin or its via
2. Connect all GND pins to package thermal pad which must be connected to the GND plane for better thermal distribution and signal conducting with reasonable via count (>8)

**Selection Table 1 – 80M Spread Spectrum Selection Table**

S1	S0	Spread %
0	0	-1.0%
0	1	OFF
1	0	-0.5%
1	1	-0.75%

Refer to Byte0 control register.

Default setting is S1:S0 = 01

## Serial Data Interface (SMBus)

PI6C49016 is a slave only SMBus device that supports indexed block read and indexed block write protocol using a single 7-bit address and read/write bit as shown below.

### Address Assignment

A6	A5	A4	A3	A2	A1	A0	W/R
1	1	0	1	0	0	1	0/1

### How to Write

1 bit	8 bits	1	8 bits	1	8 bits	1	8 bits	1		8 bits	1	1 bit
Start bit	D2H	Ack	Register offset	Ack	Byte Count = N	Ack	Data Byte 0	Ack	...	Data Byte N - 1	Ack	Stop bit

Note:

1. Register offset for indicating the starting register for indexed block write and indexed block read. Byte Count in write mode cannot be 0.

### How to Read (M: abbreviation for Master or Controller; S: abbreviation for slave/clock)

1 bit	8 bits	1 bit	8 bits	1 bit	1 bit	8 bits	1 bit	8 bits	1 bit	8 bits	1 bit	...	8 bits	1 bit	1 bit
M: Start bit	M: Send "D2h"	S: sends Ack	M: send starting databyte location: N	S: sends Ack	M: Start bit	M: Send "D3h"	S: sends Ack	S: sends # of data bytes that will be sent: X	M: sends Ack	S: sends starting data byte N	M: sends Ack	...	S: sends data byte N+X-1	M: Not Acknowledge	M: Stop bit

### Byte 0: Spread Spectrum Control Register

Bit	Description	Type	Power Up Condition	Output(s) Affected	Notes
7	Spread Select for 100 MHz push-pull PCI-Express clocks	RW	0	All 100MHz PCI-Express outputs	0=spread off 1 = -0.5% down spread
6	Reserved	R	-	-	-
5	Global $\overline{\text{PD\_RESET}}$ bit. Enables or disables all outputs.	RW	1	All outputs	0 = disabled 1 = enabled
4	Spread Select for 80MHz S1	RW	0	80M	See Table 1 on Page4
3	Spread Select for 80MHz S0	RW	1		
2	OE for 66.66 MHz output	RW	1	66.66M	0 = disabled 1 = enabled
1	Reserved	R	-	-	-
0	OE for single-ended 125MHz	RW	1	Single-ended 125MHz	0 = disabled 1 = enabled

**Byte 1: Control Register**

Bit	Description	Type	Power Up Condition	Output(s) Affected	Notes
7	OE for 80MHz output	RW	1	80MHz	1 = enabled 0 = disabled
6 to 0	Reserved	R	-	-	-

**Byte 2: Control Register**

Bit	Description	Type	Power Up Condition	Output(s) Affected	Notes
7 to 0	Reserved	R	-	-	-

**Byte 3: Control Register**

Bit	Description	Type	Power Up Condition	Output(s) Affected	Notes
7	Reserved	RW	-	-	-
6	Reserved	RW	-	-	-
5	Reserved	RW	-	-	-
4	OE for 100 MHz PCI-Express output PCIE2	RW	1	100 MHz PCI-Express output PCIE2	1 = enabled 0 = disabled
3	Reserved	RW	-	-	-
2	OE for 100 MHz PCI-Express output PCIE1	RW	1	100 MHz PCI-Express output PCIE1	1 = enabled 0 = disabled
1	OE for 100 MHz PCI-Express output PCIE0	RW	1	100 MHz PCI-Express output PCIE0	1 = enabled 0 = disabled
0	Reserved	R	-	-	-

**Byte 4: Control Register**

Bit	Description	Type	Power Up Condition	Output(s) Affected	Notes
7 to 0	Reserved	R	-	-	-

**Byte 5: Control Register**

Bit	Description	Type	Power Up Condition	Output(s) Affected	Notes
7	Revision ID bit 3	R	0	-	-
6	Revision ID bit 2	R	0	-	-
5	Revision ID bit 1	R	0	-	-
4	Revision ID bit 0	R	0	-	-
3	Vendor ID bit 3	R	0	-	-
2	Vendor ID bit 2	R	0	-	-
1	Vendor ID bit 1	R	0	-	-
0	Vendor ID bit 0	R	0	-	-

**Byte 6: Control Register**

Bit	Description	Type	Power Up Condition	Output(s) Affected	Notes
7 to 0	Reserved	R	-	-	-

### Maximum Ratings

(Above which useful life may be impaired. For user guidelines, not tested.)

Maximum Supply Voltage, $V_{DD}$ .....	4.6V
All Inputs and Outputs .....	-0.5V to $V_{DD}$ +0.5V
Ambient Operating Temperature .....	-40°C to +85°C
Storage Temperature .....	-65°C to +150°C
ESD Protection (HBM) .....	2000V

**Note:**

Stresses above the ratings listed below can cause permanent damage to the PI6C49016. These ratings, which are standard values for Pericom commercially rated parts, are stress ratings only. Functional operation of the device at these or any other conditions above those indicated in the operational sections of the specifications is not implied. Exposure to absolute maximum rating conditions for extended periods can affect product reliability. Electrical parameters are guaranteed only over the recommended operating temperature range.

### Recommended Operation Conditions

Parameters	Min.	Typ.	Max.	Units
Ambient Operating Temperature	-40		+85	°C
Power Supply Voltage (measured in respect to GND)	+3.135	3.3	+3.465	V
Output Supply Voltage, $V_{DDO2}$	+2.25		+3.6	V
Minimum Pulse Width of $\overline{PD\_RESET}$ Input	100			ns

### DC Electrical Characteristics

Unless otherwise specified,  $V_{DD}=3.3V\pm5\%$ ,  $V_{DDO2}=2.5V$ , Ambient Temperature -40°C to +85°C

Parameter	Symbol	Conditions	Min	Typ	Max	Units
Operating Supply Voltage	$V_{DD}$		3.135	3.3	3.465	V
Output Supply Voltage	$V_{DDO2}$		2.25	2.5	3.6	
Input High Voltage	$V_{IH}$	X1/ICLK, SCLK, SDATA, $\overline{PD\_RESET}$	2		$V_{DD}$	
Input Low Voltage	$V_{IL}$	X1/ICLK, SCLK, SDATA, $\overline{PD\_RESET}$	-0.3		0.8	
Operating Supply Current	$I_{DD}$	No load, all supply pins, $\overline{PD\_RESET} = 1$		90	115	mA
IDD at Output Disable Condition		$\overline{PD\_RESET} = 0$		6		
Short Circuit Current	$I_{OS}$	Single-ended clocks		±35		
Internal Pull-Up/Pull-Down Resistor	$R_{PU}/R_{PD}$	$\overline{PD\_RESET}$		240		kΩ
		All single-ended clocks		110		
Input Capacitance	$C_{IN}$	All input pins		6		pF



### Electrical Characteristics - Single-Ended

Unless otherwise specified,  $V_{DD}=3.3V\pm 5\%$ ,  $V_{DDO2}=2.5V$ , Ambient Temperature  $-40^{\circ}C$  to  $+85^{\circ}C$

Parameter	Symbol	Conditions	Min	Typ	Max	Units
Input Clock Frequency	$F_{IN}$			25		MHz
Output Frequency Error				0		ppm
Output Rise Time	$t_{OR}$	20% to 80% <sup>1</sup>		0.5	1	ns
		0.7 V to 1.7V 125 MHz <sup>4</sup>			0.4	
Output Fall Time	$t_{OF}$	80% to 20% <sup>1</sup>		0.5	1.35	ns
		1.7 V to 0.7V 125 MHz <sup>4</sup>			0.4	
Output Clock Duty Cycle		Measured at VDD/2, 125M	47	50	53	%
		Measured at VDD/2, all other outputs	45	50	55	
High-Level Output Voltage	$V_{OH}$	$I_{OH} = -4mA$	VDD-0.4			V
High-Level Output Voltage	$V_{OH}$	$I_{OH} = -8mA$	2.1			V
Low-Level Output Voltage	$V_{OL}$	$I_{OL} = 8mA$			0.4	V
Peak-to-Peak Jitter		66.66 MHz clock output		$\pm 150$		ps
		125 MHz clock output		$\pm 100$		
Cycle-to-Cycle Jitter		125 MHz clock output			$\pm 100$	ps
		80 MHz clock output <sup>2,3</sup>			$\pm 100$	
Phase Noise		66.66 MHz, 500 kHz offset	-56			dB
Modulation Rate		80MHz		32	60	kHz
Clock Stabilization Time from Power Up		$\overline{PD\_RESET}$ goes high to 1% of final frequency	3		10	ms

Note 1: CL = 15 pF

Note 2: Cycle-to-cycle jitter is measured at 25°C.

Note 3: Spread OFF.

Note 4: CL = 5 pF

## Electrical Characteristics - 100MHz Differential Push-Pull Outputs

Unless otherwise specified,  $V_{DD}=3.3V\pm 5\%$ , Ambient Temperature  $-40^{\circ}C$  to  $+85^{\circ}C$

Parameter	Symbol	Conditions	Min	Typ	Max	Units
Output Frequency					100	MHz
Cycle-to-Cycle Jitter	$T_{CC/Jitter}$				150	ps
Peak-to-Peak Phase Jitter		PCIe Gen1 filter function			86	
PCIe 2.0 RMS Phase Jitter	$J_{RMS2.0}$	PCIe 2.0 Test Method @ 100 MHz Output			3.1	ps
Spread Range				-0.5	0	%
Spread Rate				32		kHz
Duty Cycle	$T_{DC}$		45	50	55	%
Clock Stabilization from Power Up				3.5		ms
Rising Edge Rate		Note3, 4	0.6		4.0	V/ns
Falling Edge Rate		Note3, 4	0.6		4.0	V/ns
Rise-Fall Matching		Note3, 11		20		
Output Skew	$T_{OSKEW}$	$V_T = 50\%$ (measurement threshold), Intra-pair skew			50	ps
		$V_T = 50\%$ (measurement threshold), Inter-pair skew			200	ps
Clock Source DC Impedance( $Z_o$ )	$Z_{C-DC}$			17		$\Omega$
High-Level Output Voltage	$V_{OH}$	$V_{DD}=3.3V$ Note2 ( $R_s = 33\text{ohm}$ )	0.65	0.71	0.90	V
Low-Level Output Voltage	$V_{OL}$		-0.20	0	0.05	V
Absolute Crossing Point Voltage	$V_{CROSS}$	Note2, 5, 6	0.25		0.55	V
Variation of $V_{CROSS}$ over all rising clock edges	$V_{CROSS}$ Delta	Note2, 5, 8			140	mV
Average Clock Period Accuracy	$T_{PERIOD}$ AVG	Note3, 9, 10	-300		2800	ppm
Absolute Period (including jitter and spread spectrum)	$T_{PERIOD}$ ABS	Note3, 7	9.847		10.203	ns

### Notes:

1. Measured at the end of an 8-inch trace with a 5pF load.
2. Measurement taken from a single-ended waveform.
3. Measurement taken from a differential waveform.
4. Measured from -150 mV to +150 mV on the differential waveform. The signal is monotonic through the measurement region for rise and fall time. The 300 mV measurement window is centered on the differential zero crossing.
5. Measured at crossing point where the instantaneous voltage value of the rising edge of 100M+ equals the falling edge 100M-.
6. Refers to the total variation from the lowest crossing point to the highest, regardless of which edge is crossing.  
Refers to all crossing points for this measurement.

**Notes (Continued)**

7. Defines as the absolute minimum or maximum instantaneous period. This includes cycle-to-cycle jitter, relative PPM tolerance, and spread spectrum modulation.
8. Defined as the total variation of all crossing voltages of rising 100M+ and falling 100M-.
9. Refer to section 4.3.2.1 of the PCI Express Base Specification, Revision 1.1 for information regarding PPM considerations.
10. PPM refers to parts per million and is a DC absolute period accuracy specification. 1 PPM is 1/1,000,000th of 100 MHz exactly or 100 Hz. For 300 PPM there is an error budget of  $100\text{Hz}/\text{PPM} * 300 \text{ PPM} = 30 \text{ kHz}$ . The period is measured with a frequency counter with measurement window set at 100 ms or greater. With spread spectrum turned off the error is less than  $\pm 300$  ppm. With spread spectrum turned on there is an additional +2500 PPM nominal shift in maximum period resulting from the -0.5% down spread.
11. Matching applies to rising edge rate for PCIe and falling edge rate for PCIeN. It is measured using a  $\pm 75$  mV window centered on the median cross point where PCIe rising meets PCIeN falling. The median cross point is used to calculate the voltage thresholds the oscilloscope is to use for the edge rate calculations. The rising edge rate of PCIe should be compared to the falling edge rate of PCIeN. The maximum allowed difference should not exceed 20% of the slowest edge rate.

**Application Notes**

**Crystal circuit connection**

The following diagram shows PI6C49016 crystal circuit connection with a parallel crystal. For the CL=18pF crystal, it is suggested to use C1= 27pF, C2= 27pF. C1 and C2 can be adjusted to fine tune to the target ppm of crystal oscillator according to different board layouts.

**Crystal Oscillator Circuit**

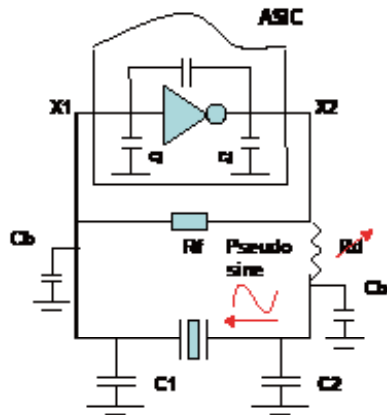
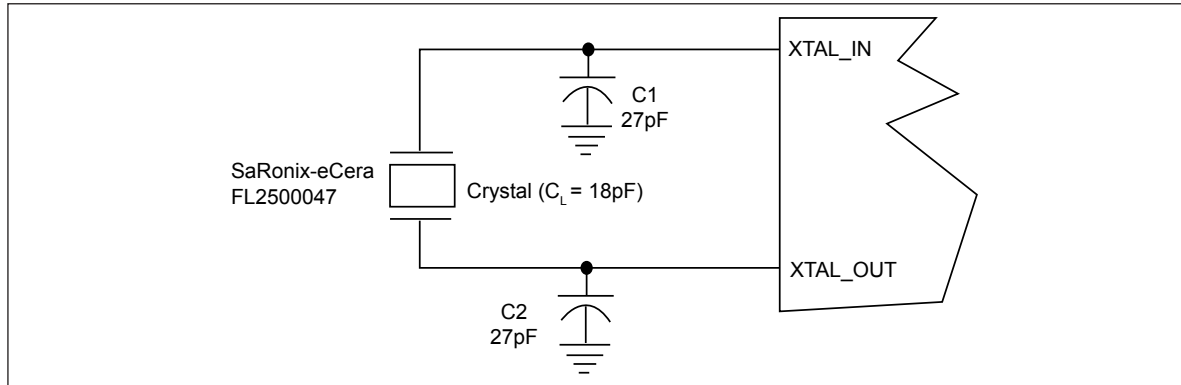

- CL= crystal spec. loading cap.
- Cj= chip input/output cap. (2-5pF)
- Cb= PCB trace/via cap. (2-4pF)
- C1,2= load cap. components
- Rd= drive level res. (10kOhm)

Final choose from  $C1=C2=2 * CL - (Cb + Cj)$  for the target +/-ppm  
 Example:  $C1=C2=2*(18pF) - (4pF+5pF)=27pF$

**Recommended Crystal Specification**

Pericom recommends:

- a) FY2500081, SMD 5x3.2(4P), 25M, CL=18pF, +/-30ppm, [http://www.pericom.com/pdf/datasheets/se/FY\\_F9.pdf](http://www.pericom.com/pdf/datasheets/se/FY_F9.pdf)
- b) FL2500047, SMD 3.2x2.5(4P), 25M, CL=18pF, +/-20ppm, <http://www.pericom.com/pdf/datasheets/se/FL.pdf>

## Decoupling Capacitors

Decoupling capacitors of 0.01  $\mu$ F should be connected between VDD and GND as close to the device as possible. Do not share ground vias between components. Route power from power source through the capacitor pad and then into PI6C49016 pin.

## Output Termination

The PCI-Express differential clock outputs of the PI6C49016 are push-pull and require an external series resistor. These resistor values and their allowable locations are shown in detail in the PCI-Express Layout Guidelines section.

## PCB Layout Recommendations

For optimum device performance and lowest output phase noise, the following guidelines should be observed.

1. Each 0.01 $\mu$ F decoupling capacitor should be mounted on the component side of the board as close to the VDD pin as possible.
2. No vias should be used between decoupling capacitor and VDD pin.
3. The PCB trace to VDD pin should be kept as short as possible, as should the PCB trace to the ground via. Distance of the ferrite bead and bulk decoupling from the device is less critical.
4. An optimum layout is one with all components on the same side of the board, minimizing vias through other signal layers (any ferrite beads and bulk decoupling capacitors can be mounted on the back). Other signal traces should be routed away from PI6C49016. This includes signal traces just underneath the device, or on layers adjacent to the ground plane layer used by the device.

**PCI-Express Layout Guidelines**

Common Recommendations for Differential Routing	Dimension or Value	Unit	Figure	Notes
L1 length, Route as non-coupled 50 ohm trace.	0.5 max	inch	1,2	
L2 length, Route as non-coupled 50 ohm trace.	0.2 max	inch	1,2	
L3 length, Route as non-coupled 50 ohm trace.	0.2 max	inch	1,2	
$R_s$	33	ohm	1,2	

Down Device Differential Routing	Dimension or Value	Unit	Figure	Notes
L4 length, Route as coupled microstrip 100 ohm differential trace.	2 min to 16 max	inch	1	
L4 length, Route as coupled stripline 100 ohm differential trace.	1.8 min to 14.4 max	inch	1	

**Figure 1: Down Device Routing**

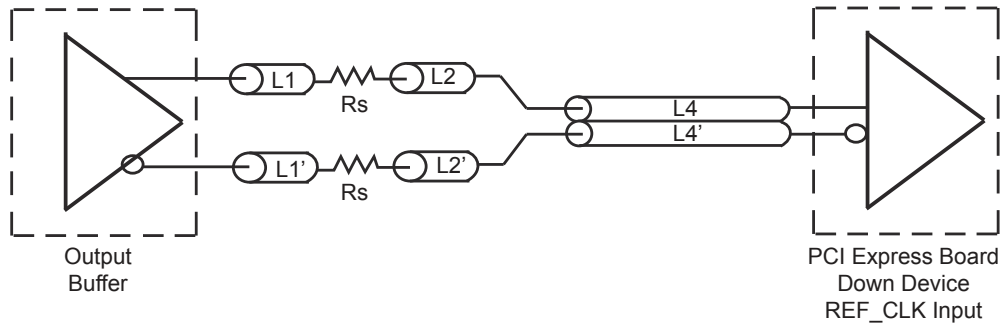

**Figure 2: PCI-Express Connector Routing**

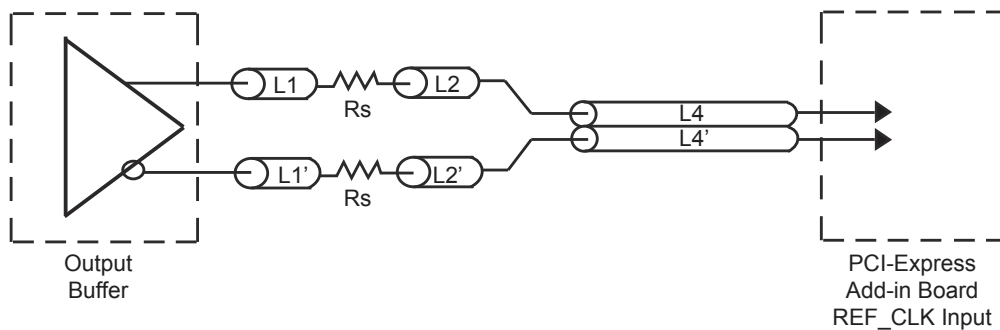

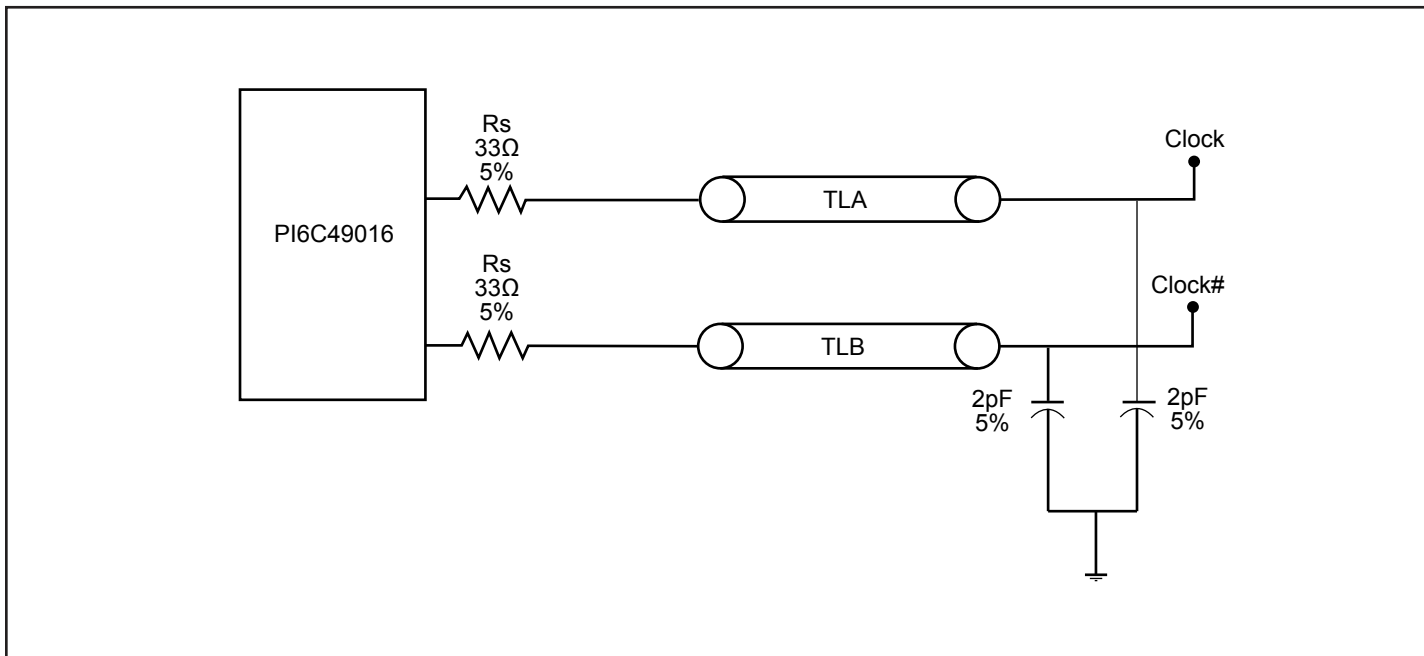
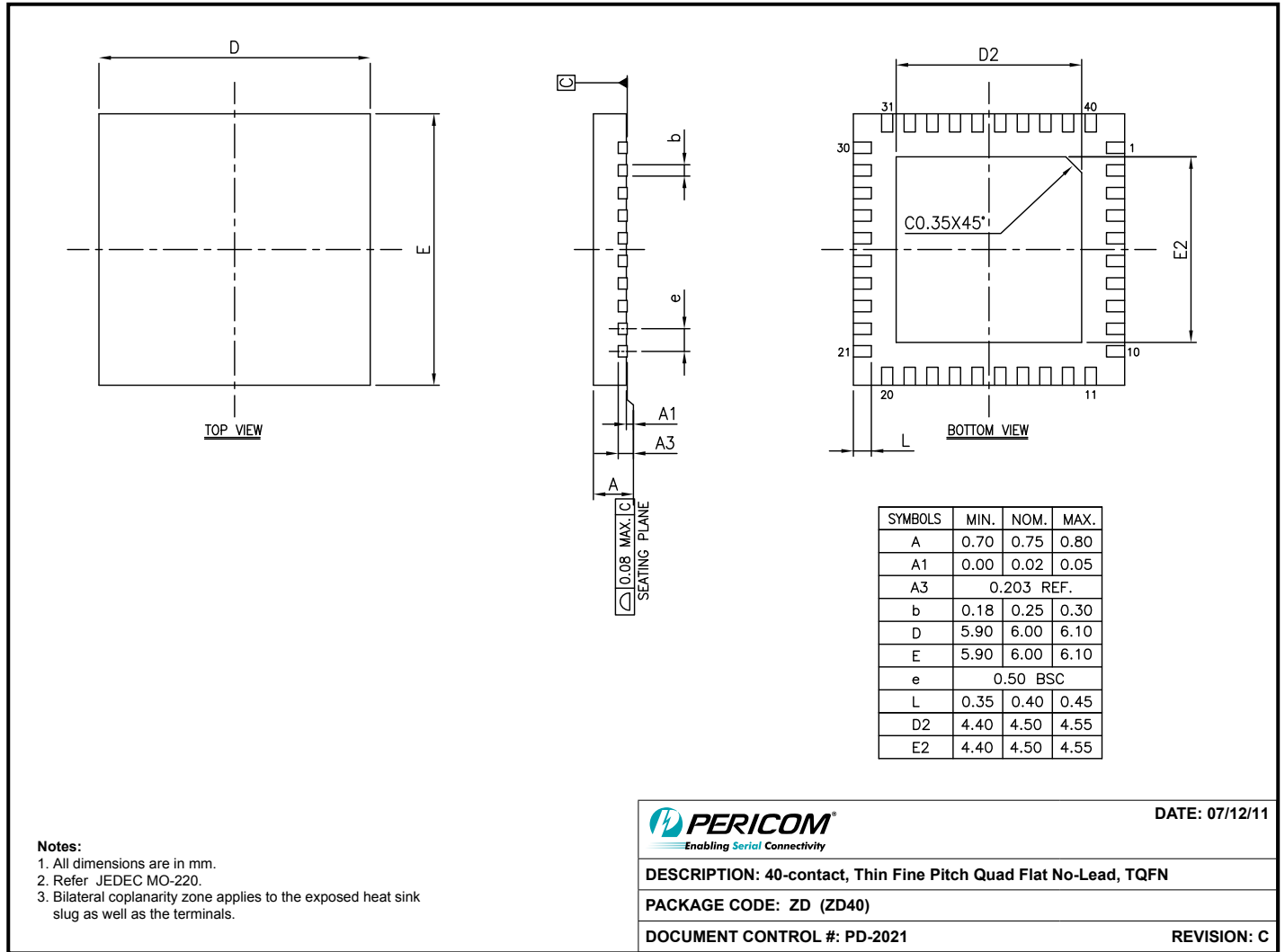

Figure 4. Configuration Test Load Board Termination



**Note:**  
• For latest package info, please check: <http://www.pericom.com/products/packaging/mechanicals.php>

### Ordering Information<sup>(1-3)</sup>

Ordering Code	Package Code	Package Description
PI6C49016ZDIE	ZD	40-pin, Pb-free & Green, TQFN, (ZD40)
PI6C49016ZDIEX	ZD	40-pin, Pb-free & Green, TQFN, (ZD40), Tape & Reel

- Notes:**
- Thermal characteristics can be found on the company web site at [www.pericom.com/packaging/](http://www.pericom.com/packaging/)
  - E = Pb-free and Green
  - Adding an X suffix = Tape/Reel