

DD51 | Mechanical position indicators

direct drive, 4-digit counter, technopolymer

INCH

INOX
STAINLESS
STEEL

RoHS

PA

PA-T

+176 °F
+32 °F

- 1
- 2
- 3
- 4
- 5
- 6
- 7
- 8
- 9
- 10
- 11
- 12
- 13
- 14
- 15
- 16
- 17
- 18

BASE AND CASE

High-resistance polyamide based (PA) technopolymer.
Black base.

Case in the following colours:

- **C2:** RAL 2004 orange, glossy finish.
- **C3:** RAL 7035 grey, glossy finish.
- **C1:** RAL 7021 grey-black, glossy finish.

The ultrasonic welding between the base and the case prevents separation and avoids dust penetration.

WINDOW

Transparent polyamide based (PA-T) technopolymer, moulded over the case and with a perfect seal. Resistant to solvents, oils, greases and other chemical agents (avoid contact with alcohol during cleaning operations).

DISPLAY

It indicates the displacement of the mechanism controlled by the spindle from the start position (0).

Four-digit roller counter. The digits of red rolls show the decimal values. An additional graduated scale next to the last decimal digit offers further accuracy of reading.

The display can be in different positions (see "Table of the possible combinations").

- **AN:** inclined display, counter in upper position.
- **AR:** inclined display, counter in lower position.
- **FN:** front display, counter in upper position.
- **FR:** front display, counter in lower position.

INTERNAL GASKET

O-ring front sealing in NBR synthetic rubber, between the case and the boss.

REAR GASKET

Foam polyethylene, supplied.

STANDARD EXECUTION

Boss with DIA 0.500 (Ø 12.7 mm) standard reamed hole, fitting to shaft by means of a grub screw with hexagon socket and cup end, included in the supply.

- **DD51:** black-oxide steel boss.
- **DD51-SST:** AISI 303 stainless steel boss.

DIRECTION OF ROTATION

- **D:** clockwise. Increasing values with clockwise rotation of the boss.
- **S:** anti-clockwise. Increasing values with anti-clockwise rotation of the boss.

WEIGHT

0.152 lbs.

FEATURES AND APPLICATIONS

Direct drive digital position indicators can be assembled on passing through spindles in any position to give direct reading of the positioning of a machine component. They are suitable also for motor driven applications (see "Table of the possible combinations").

ERGONOMY AND DESIGN

Compact roller counter, ergonomically designed digits for rapid reading. The readability of the counter is increased by the magnifying window.

ASSEMBLY INSTRUCTIONS

1. Drill a DIA 0.24 by 0.39 (Ø 6 mm by Ø 10 mm) hole in the body of the machine with a 0.87 (22 mm) centre distance from the spindle to fit the rear referring pin.
2. Set the spindle to the start or referring position.
3. Fit the indicator with the zeroed roller counter onto the spindle and make sure that the referring pin fit the hole.
4. Clamp the boss to the spindle by tightening the grub screw with hexagon socket and cup end.



ELESA Original design

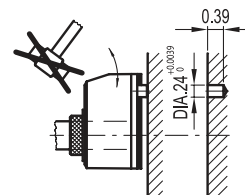
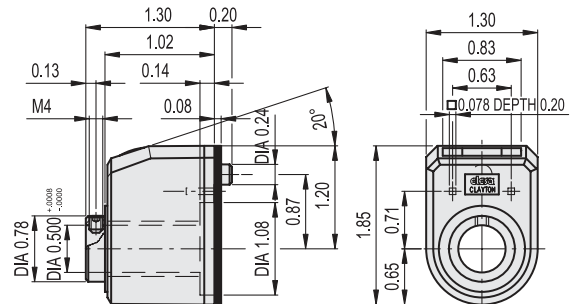

Example of description for ordering

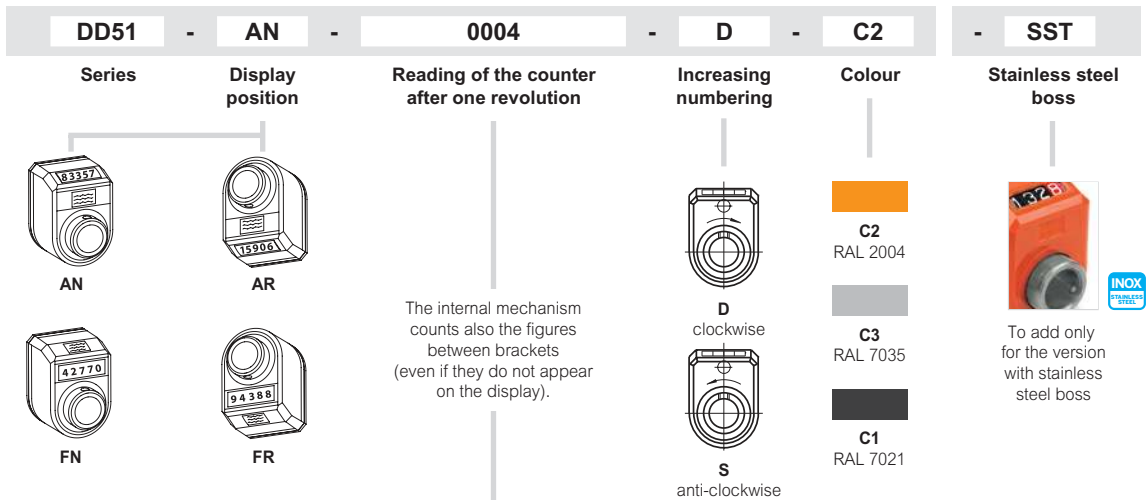

0 0 0 4	0 0 0 4	0 0 0 4	0 0 0 4	Pitch threads per inch	inches per threads	Speed (rpm) *
0004	000.4	00.04	0.004	2.5	0.4	1500
0010	001.0	00.10	0.010	10	0.1	1500
0012(5)	001.2(5)	00.12(5)	0.012(5)	8	0.125	1500
0015	001.5	00.15	0.015	-	1.5	1500
0015(7)	001.5(7)	00.15(7)	0.015(7)	-	1.575	1500
0017(5)	001.7(5)	00.17(5)	0.017(5)	-	1.75	1420
0020	002.0	00.20	0.020	5	2.0	1250
0020(83)	002.0(83)	00.20(83)	0.020(83)	-	2.083	1200
0025	002.5	00.25	0.025	4	2.5	1000
0030	003.0	00.30	0.030	-	3.0	830
0040	004.0	00.40	0.040	2.5	4.0	625
0044	004.4	00.44	0.044	-	4.4	550
0050	005.0	00.50	0.050	2	5.0	500
0057	005.7	00.57	0.057	-	5.7	435
0060	006.0	00.60	0.060	-	6.0	415
0065(5)	006.5(5)	00.65(5)	0.065(5)	-	6.55	370
0075	007.5	00.75	0.075	-	7.5	330
0080	008.0	00.80	0.080	1.25	8.0	315
0083(3)	008.3(3)	00.83(3)	0.083(3)	-	8.33	300
0100	010.0	01.00	0.100	10	10.0	250
0120	012.0	01.20	0.120	-	12.0	205
0125	012.5	01.25	0.125	8	12.5	200
0157	015.7	01.57	0.157	-	15.7	150
0200	020.0	02.00	0.200	5	20.0	125

* The maximum rotation speed (rpm) of the spindle reported in the table corresponds to a maximum rotation of 2500 units of the last roll on the right of the counter.
 Rotational speed tests have been performed in our laboratory under standard operating conditions.
 Small misalignments (not compromising the correct reading) of counter digits can occur due to high tolerances between gear teeth, designed to prevent damage from sudden acceleration or stop.

- 1
- 2
- 3
- 4
- 5
- 6
- 7
- 8
- 9
- 10
- 11
- 12
- 13
- 14
- 15
- 16
- 17
- 18

Position indicators

- 1
- 2
- 3
- 4
- 5
- 6
- 7
- 8
- 9
- 10
- 11
- 12
- 13
- 14
- 15
- 16
- 17
- 18

SPECIAL EXECUTIONS ON REQUEST

- Special readings after one revolution.
- Case in different colours.
- Completely sealed digital position indicators with IP 67 protection class, see EN 60529 table (on page A-19) obtained by means of a brass bushing with double seal ring inside the rear cavity of the base.

LB - LOCKING DEVICE

The DD51-LB position indicators are designed to lock the spindle on which they are mounted to avoid the risk of accidental adjustment alterations due to vibrations. To lock or unlock the spindle rotation, simply move the lever, in pos. A equivalent to unlocked spindle, in pos. B equivalent to locked spindle. Following repeated locking cycles, the special device is highly wear resistant and functions perfectly over time. To order the indicator with spindle locking add the -LB index after the code and description (e.g. CE.84101-LB DD51-AN-00.50-D-C3-LB).

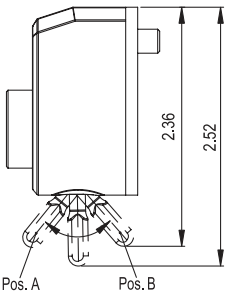

ACCESSORIES ON REQUEST (TO BE ORDERED SEPARATELY)

- **BS51:** glass-fibre reinforced polyamide based (PA) technopolymer spacer plate (code CE.85900).

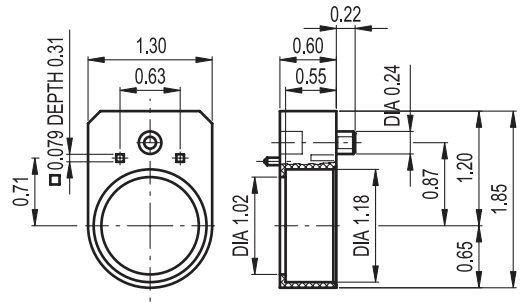

- **MDX-51:** polyamide based (PA) technopolymer knob.



- **BSA-N51:** die-cast zinc alloy bases for spindle locking, epoxy resin coating, black colour, matte finish. GN 302.1 adjustable handle with die-cast zinc alloy lever body and AISI 304 stainless steel clamping element. A Ø 6.1 mm hole to fit the referring pin of the indicator. Handle positioned either on the right or on the left. Fitting to the machine by means of two M4 cylindrical-head screws (not included in the supply).

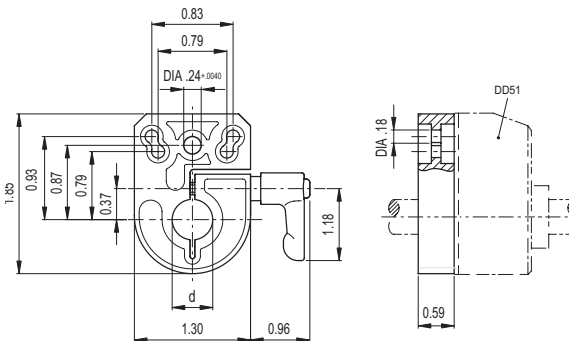

- **RB51:** black-oxide steel reduction sleeves.
- **RB51-SST:** AISI 304 stainless steel reduction sleeves.

Position indicators

INCH

Code	Description	d	⚖️
CE985915	BSA-N51-1/4	0.250	0.24
CE985917	BSA-N51-3/8	0.375	0.23
CE985919	BSA-N51-1/2	0.500	0.22

INCH

RB51

Code	Description	d
CE985940	RB51-1/2-1/4	0.250+0.0006
CE985950	RB51-1/2-3/8	0.375+0.0008

INOX STAINLESS STEEL INCH

RB51-SST

Code	Description	d
CE995941	RB51 1/2-1/4 SST-304	0.250+0.0006
CE995956	RB51 1/2-3/8-SST-304	0.375+0.0008