

PART NUMBER		SSL-LXA228SIC-TR31	REV	C
REV	E.C.N. NUMBER AND REVISION COMMENTS		DATE	
A	E.C.N #11148.		11.15.06	
B	E.C.N #11508.		06.13.08	
C	ECN-Lumex202200029		04.07.22	

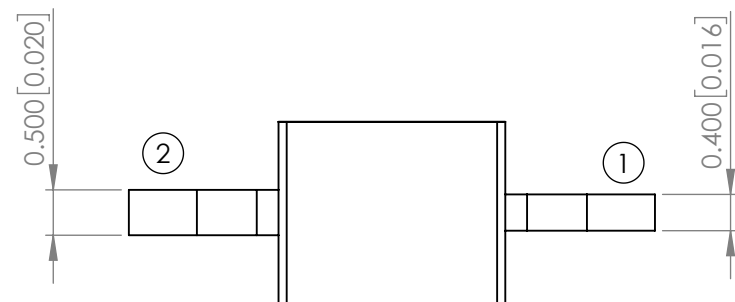

**POLARITY**

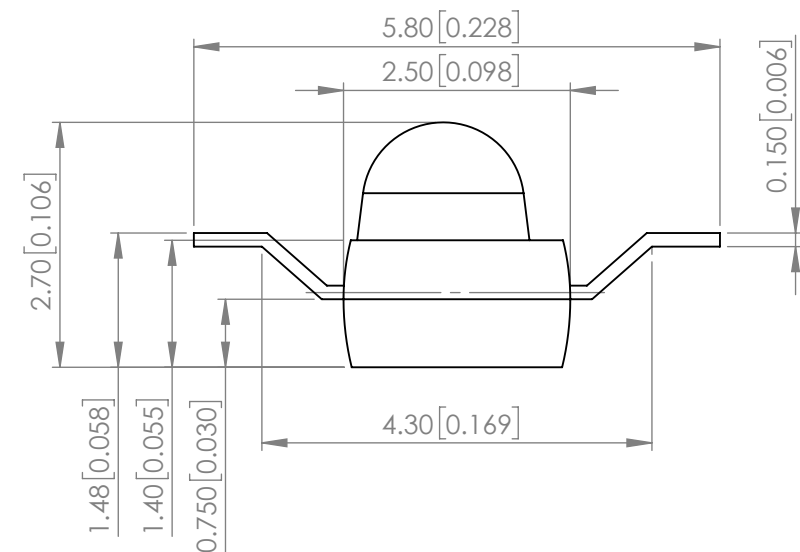
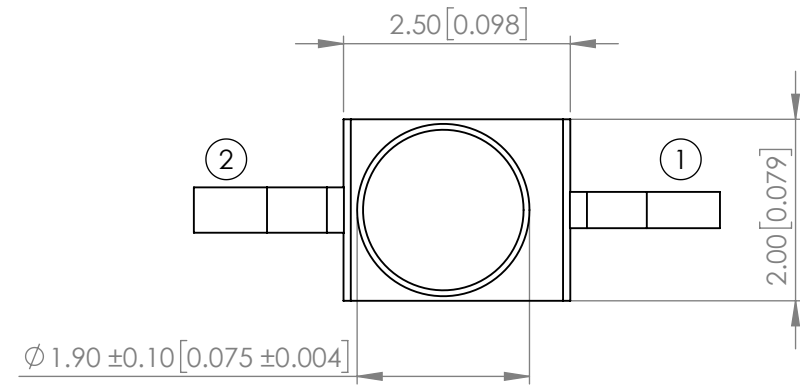
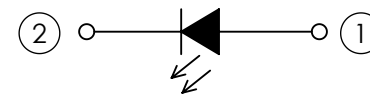

**ELECTRO-OPTICAL CHARACTERISTIC TA=25°C**

PARAMETER	MIN	TYP	MAX	UNITS	TEST COND
PEAK WAVELENGTH	-	632	-	nm	If=20mA
FORWARD VOLTAGE	-	2.0	2.4	Vf	If=20mA
REVERSE CURRENT	-	-	10	uA	Vr=5V
LUMINOUS INTENSITY	-	475	-	mcd	If=20mA
VIEWING ANGLE	-	25	-	2x theta1/2	-
EMITTED COLOR	RED				
EPOXY LENS FINISH	WATER CLEAR				

**ABSOLUTE MAXIMUM RATINGS TA=25°C**

PARAMETER	MAX	UNITS
PEAK FORWARD CURRENT*	160	mA
FORWARD CURRENT	25	mA
POWER DISIPATION	60	mW
STORAGE TEMPERATURE	-40 TO +100	°C
OPERATING TEMPERATURE	-40 TO +85	°C

\*DUTY 1/10@1KHz

**RECOMMENDED SOLDER PAD LAYOUT**

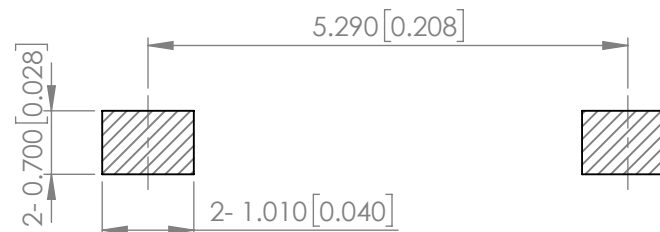

MOISTURE SENSITIVE DEVICE  
PER JEDEC LEVEL 4 STANDARDS

\*UNLESS OTHERWISE SPECIFIED TOLERANCES PER DECIMAL PRECISION ARE: X=±1 (±0.039), X.X=±0.5 (±0.020), X.XX=±0.25 (±0.010), X.XXX=±0.127 (±0.005). LEAD SIZE=±0.05 (±0.002), LEAD LENGTH=±0.75 (±0.030). MIN= <sup>+DECIMAL PRECISION</sup>/<sub>-0.00</sub> MAX= <sup>+0.00</sup>/<sub>-DECIMAL PRECISION</sub>

**PROFILE**

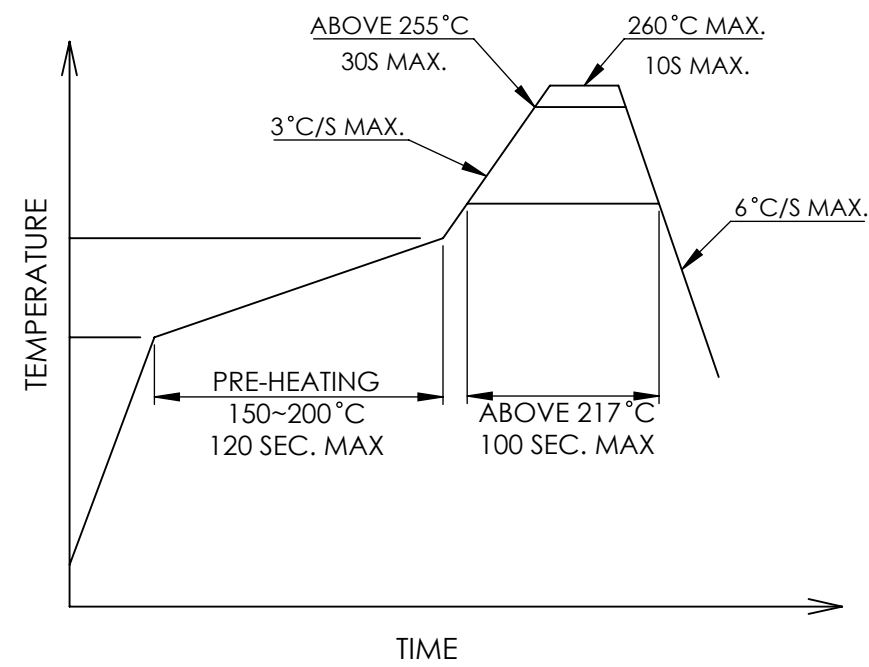

**CARRIER TAPE DIMENSION**

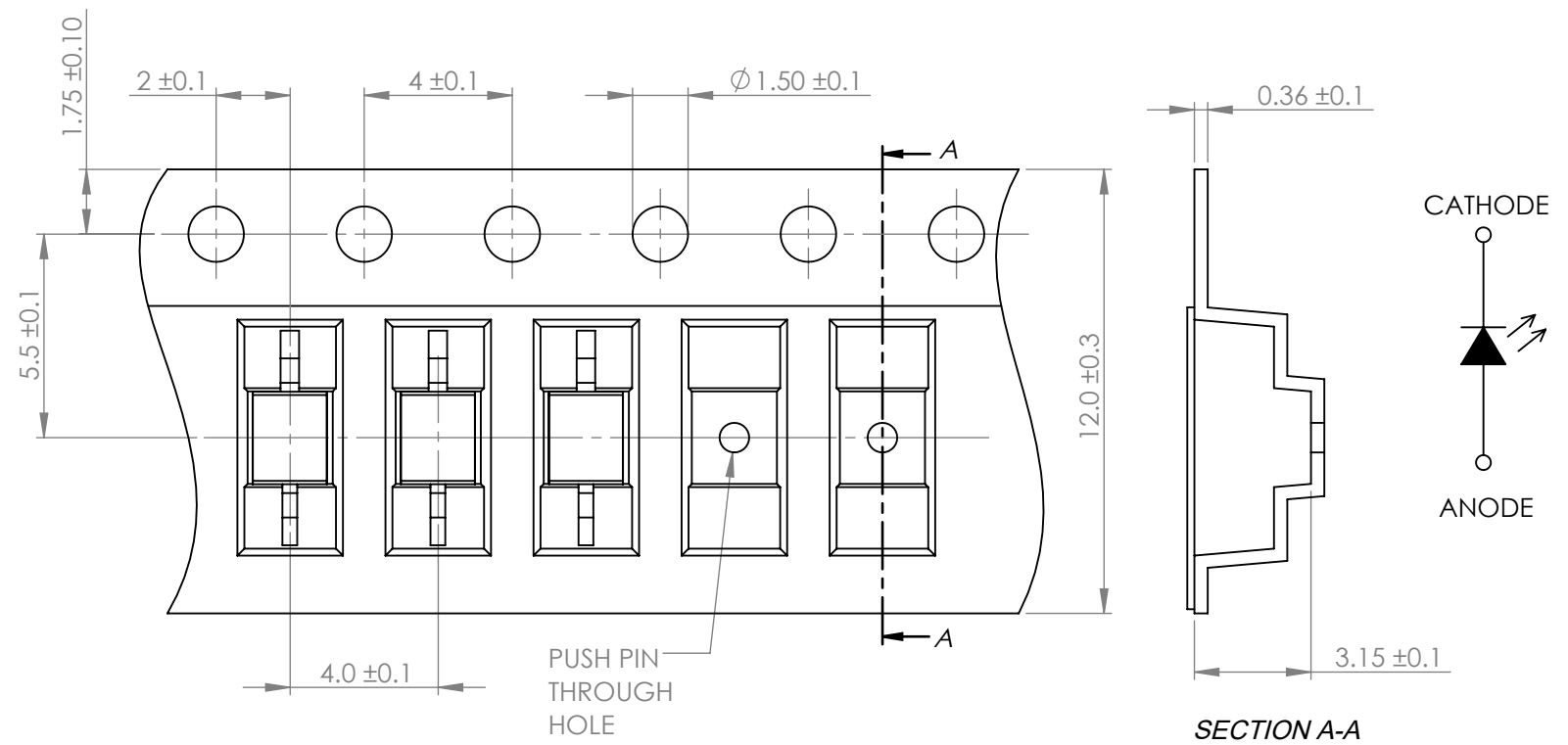

**NOTE:**  
1. 1,000 PCS PER REEL.

\*UNLESS OTHERWISE SPECIFIED TOLERANCES PER DECIMAL PRECISION ARE: X=±1 (±0.039), X.X=±0.5 (±0.020), X.XX=±0.25 (±0.010), X.XXX=±0.127 (±0.005). LEAD SIZE=±0.05 (±0.002), LEAD LENGTH=±0.75 (±0.030). MIN= <sup>+DECIMAL PRECISION</sup>/<sub>-0.00</sub> MAX.= <sup>+0.00</sup>/<sub>-DECIMAL PRECISION</sub>

 <p>425 N. GARY AVE. CAROL STREAM, IL 60188 PHONE : 800-278-5666 FAX : 630-315-2150 WEB : WWW.LUMEX.COM</p>	2(L)*5.8(W)*2.7(H)mm, AXIAL LED, 632nm RED, WATER CLEAR LENS, TAPE & REEL.		DATE : 2022.04.07	DRAWN BY : C.C.
	**THE SPECIFICATIONS MAY CHANGE AT ANY TIME WITHOUT NOTICE.**		PAGE : 2 OF 2	CHKD BY : G.Y.
	CONFIDENTIAL INFORMATION THE INFORMATION CONTAINED IN THIS DOCUMENT IS THE PROPERTY OF LUMEX INC. EXCEPT AS SPECIFICALLY AUTHORIZED IN WRITING BY LUMEX INC., THE HOLDER OF THIS DOCUMENT SHALL KEEP ALL INFORMATION CONTAINED HEREIN CONFIDENTIAL AND SHALL PROTECT SAME IN WHOLE OR IN PART FROM DISCLOSURE AND DISSEMINATION TO ALL THIRD PARTIES.		SCALE : NTF	APRVD BY : E.C.
			UNIT : mm [INCH]	(No)