

NOTES:

1. MATERIALS AND FINISHES:
 FERRULE - COPPER TUBING, WHITE BRONZE PLATING
 RETAINING RING - SUS 304, NATURAL
 BODY - BRASS, WHITE BRONZE PLATING
 CONTACT - BRASS, GOLD PLATING
 THE OTHER METAL PARTS - BRASS, WHITE BRONZE PLATING
 GASKET - SILICONE RUBBER, RED
 INSULATOR - PTFE, NATURAL
2. ELECTRICAL:
 A. IMPEDANCE: 50 OHM
 B. FREQUENCY RANGE: 0-11 GHz
 C. DIELECTRIC WITHSTANDING VOLTAGE: 2500 VRMS, MIN.
3. MECHANICAL:
 A. DURABILITY: 500 CYCLES MIN.
 B. TEMPERATURE RANGE: -65°C TO +165°C
4. CRIMPED FERRULE
 HEX. CRIMP SIZE .213"
5. CONTACT PIN TO SOLDER

THIRD ANGLE PROJ.

REVISIONS

REV	DESCRIPTION	DATE	ECN	APPR
A	RELEASE TO MFG.	04-Apr-14	2718	MZ
B	SYNC, UPDATE DRAWING FORMAT	21-Apr-20	14962	SH

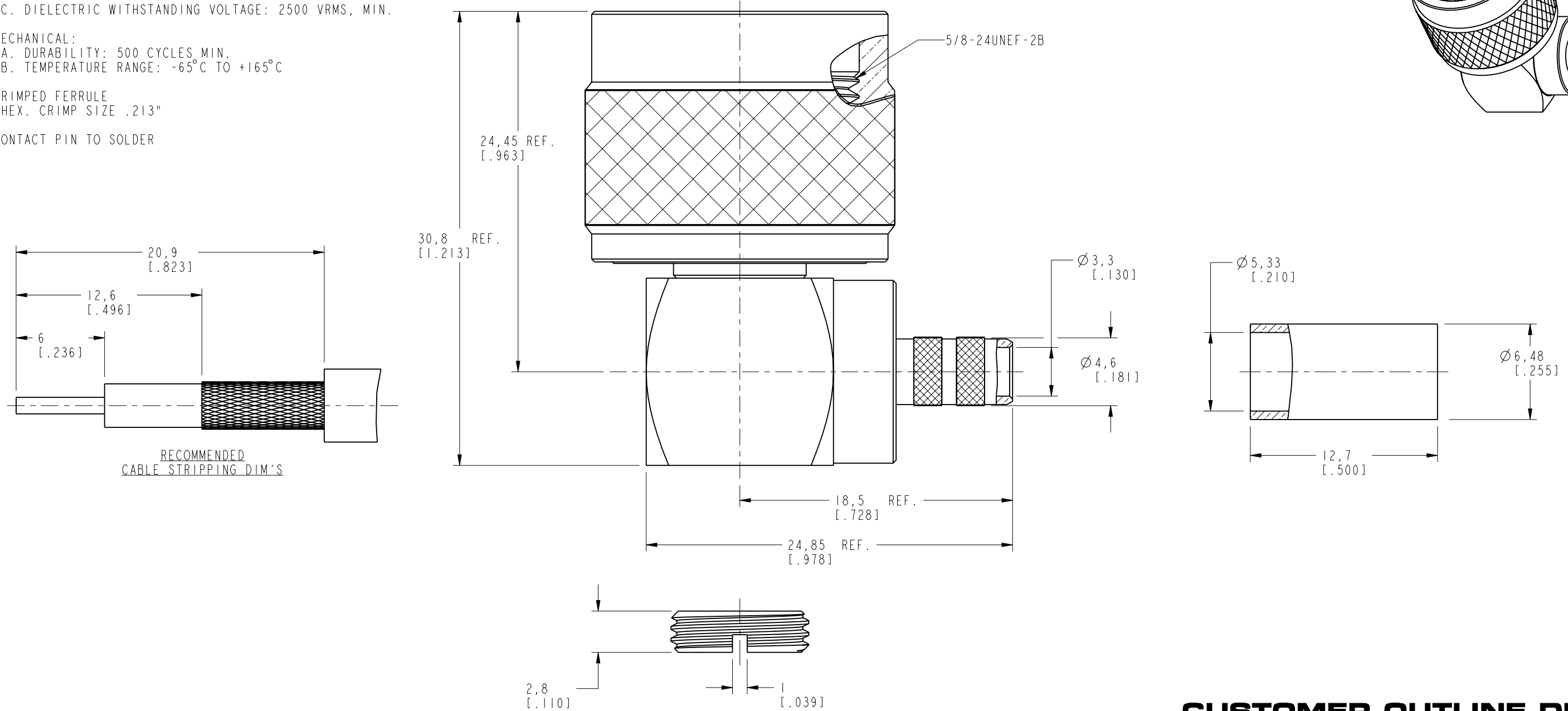
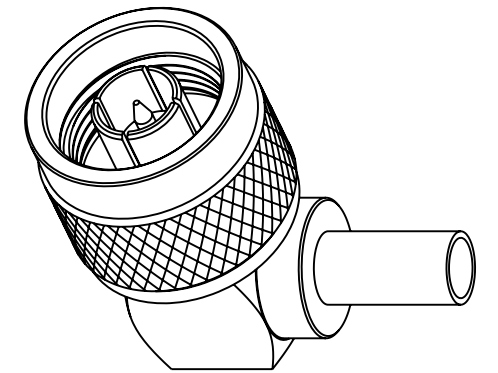

RECOMMENDED
CABLE STRIPPING DIM'S

CUSTOMER OUTLINE DRAWING
ALL OTHER SHEETS ARE FOR INTERNAL USE ONLY

UNLESS OTHERWISE SPECIFIED, DIMENSIONS ARE IN METRIC AND TOLERANCES ARE: <0.5mm ±0.05mm 0.5 - 6mm ±0.1mm 6 - 30mm ±0.2mm 30 - 120mm ±0.3mm ANGLES ±1°	MATERIAL	DRAWN	DATE	TITLE N R/A CRIMP PLUG (FOR LMR-200 CABLE)		Amphenol RF www.amphenolrf.com		
	SEE NOTES	M. ZHANG	20-Apr-20					
NOTICE - These drawings, specifications, or other data (1) are, and remain the property of Amphenol corp. (2) must be returned upon request; and (3) are confidential and not to be disclosed to any person other than those to whom they are given by Amphenol Corp. the furnishing of these drawings, specifications, or other data by Amphenol Corp., or to any other person to anyone for any purpose is not to be regarded by implication or otherwise in any manner licensing, granting rights to permitting such holder or any other person to manufacture, use or sell any product, process or design, patented or otherwise, that may in any way be related to or disclosed by said drawings, specifications, or other data.	REFERENCE	ENGINEER	DATE	SCALE: 3.5:1.0 SHEET 2 OF 2		DRAWING NO. N1112B2-AT5GP-LMR200-50 ITEM NO. 031112AAK20CP5F		
	EAR#	S. DUAN	04-Apr-14					
	REF:	APPROVED	DATE		DWG SIZE B		REV B	
	CONFIGURATION LEVEL: In Work	S. HSIEH	20-Apr-20					
FINISH	CAD FILE							