

HDSP-431G/433G

10 mm Three Digit Slim Font with 2 Colons Seven-Segment Displays

Data Sheet

Description

The 10 mm (0.4 inch) Three Digit Slim Font with 2-Colons Seven Segment Displays incorporates a new slim font character design. This slim font features narrow width, specially mitered segments to give a fuller appearance to the illuminated character. Faces of these displays are painted a neutral gray for enhanced on/off contrast.

All devices are available in either common anode or common cathode configuration with tinted green segments.

Features

- Excellent appearance
- Slim font design
- Mitered corners, evenly illuminated segments
- Gray face for optimum on/off contrast
- Choice of colors: green
- Choice of character size: 10 mm (0.4 inch)
- Characterized for luminous intensity

Devices

Green	Description
HDSP-431G	3 Digit, Common Anode, Untinted-Diffused, 0.4" Display
HDSP-433G	3 Digit, Common Cathode, Untinted-Diffused, 0.4" Display

Part Numbering System

5082 - x xx x - x x x xx

HDSP - x xx x - x x x xx

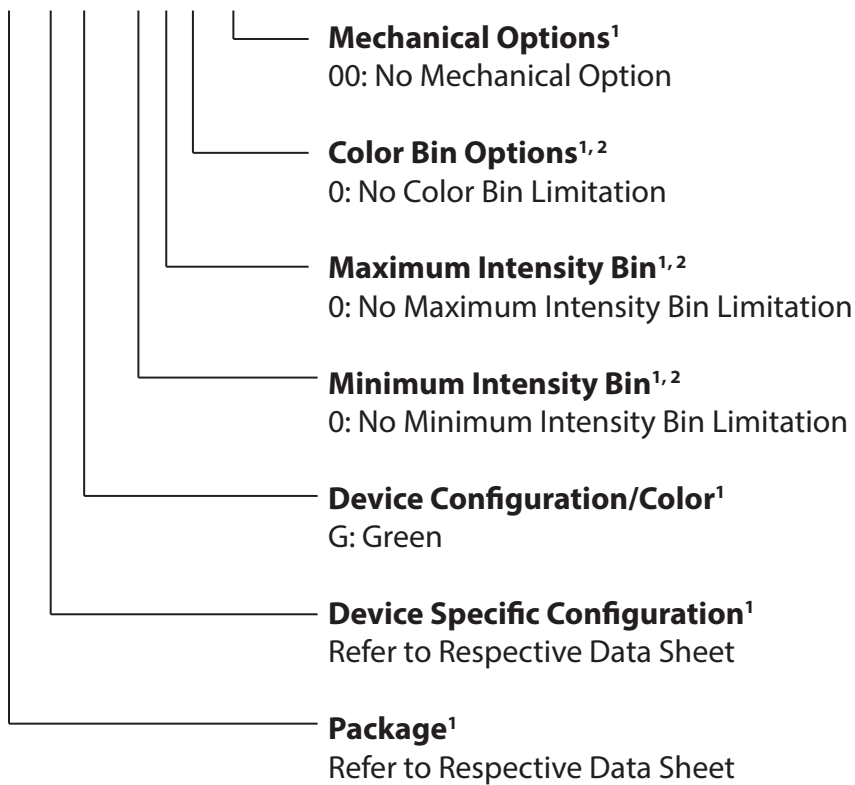

NOTE

1. For codes not listed in the figure above, please refer to the respective data sheet or contact your nearest Avago representative for details.
2. Bin options refer to shippable bins for a part-number. Color and Intensity Bins are typically restricted to 1 bin per tube (exceptions may apply). Please refer to respective data sheet for specific bin limit information.

Package Dimensions

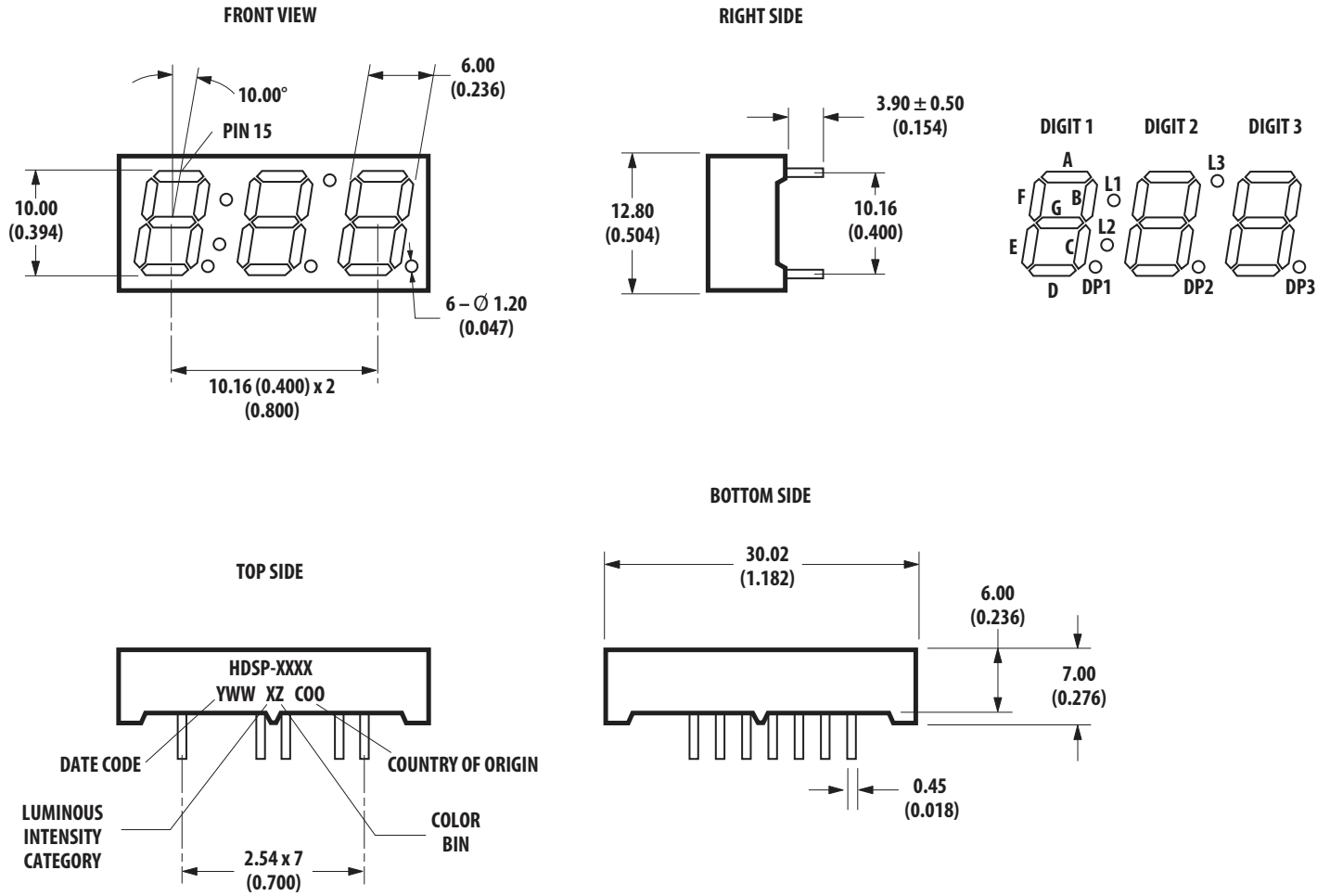

NOTE

1. All dimensions are in millimeters (inches).
2. Unless otherwise stated, tolerances are ± 0.25 mm.

Pin Information

Pin	Function
1	Digit 1 Common A/C
2	E
3	C
4	D
5	Digit 2 Common A/C
6	DP
7	Digit 3 Common A/C
8	G
9	No pin
10	No pin
11	B
12	A
13	No pin
14	L1, L2, and L3 Common A/C
15	F

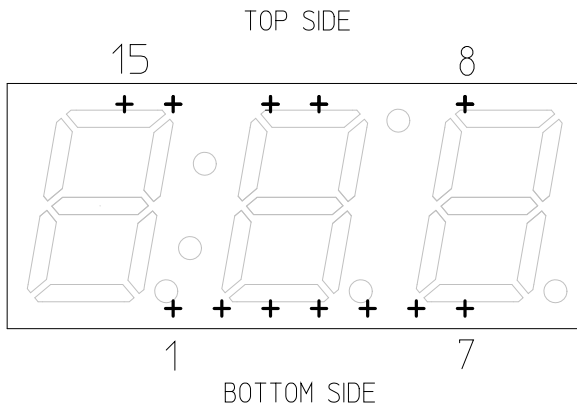

Internal Circuit Diagram (Common Cathode): HDSP-433G

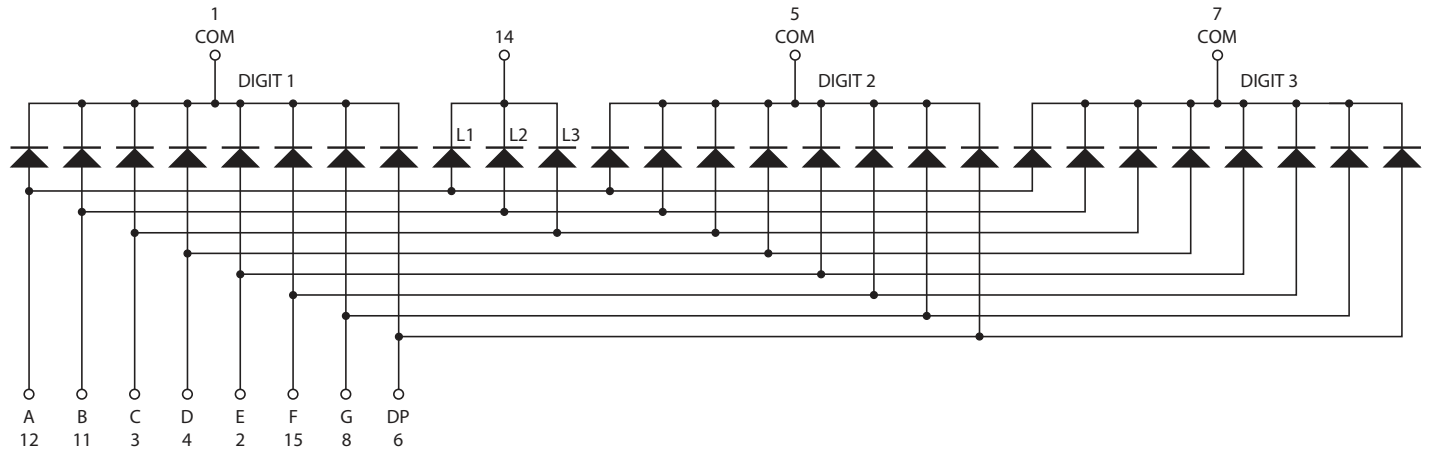

Internal Circuit Diagram (Common Anode): HDSP-431G

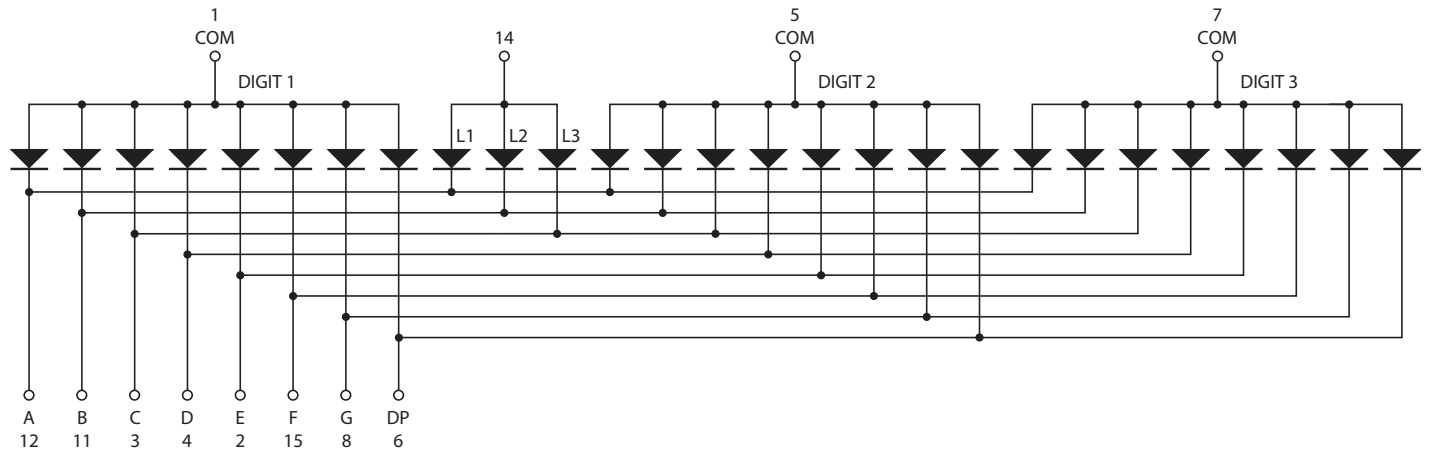

Absolute Maximum Ratings

Description	Green	Units
Average Power per Segment or DP	65	mW
Peak Forward Current per Segment or DP	100	mA
DC Forward Current per Segment or DP ¹	25	mA
Operating Temperature Range	-40 to +105	°C
Storage Temperature Range	-40 to +105	°C
Reverse Voltage per Segment or DP	3	V
Wave Soldering Temperature for 3 Seconds 1.59 mm below Body	250	°C

NOTE

1. Derate above 40 °C at 33 mA/°C for Green.

Electrical/Optical Characteristics at $T_A = 25\text{ }^\circ\text{C}$

Device Series	Parameter	Symbol	Min.	Typ.	Max.	Units	Test Conditions
HDSP-431G/ HDSP-433G	Luminous Intensity/ Segment (Digit Average)	I_V	3.200	5.000		mcd	$I_F = 10\text{ mA}$
	Forward Voltage/ Segment or DP	V_F		2.25	2.50	V	$I_F = 20\text{ mA}$
	Peak Wavelength	λ_{PEAK}		568		nm	$I_F = 20\text{ mA}$
	Dominant Wavelength	λ_d		573		nm	$I_F = 20\text{ mA}$
	Reverse Current	I_R			100	μA	$V_R = 5\text{ V}$

NOTE

1. Typical specification for reference only. Do not exceed absolute maximum ratings.
2. The dominant wavelength, λ , is derived from the CIE chromaticity diagram and is that single wavelength that defines the color of the device.

Intensity Bin Limits (mcd) Green

Green		
HDSP-431G/433G		
IV Bin Category	Min.	Max.
L	3.200	5.050
M	5.051	8.000

Color Categories

Color	Bin	Dominant Wavelength (nm)	
		Min.	Max.
Green	3	570.0	574.0
	4	567.0	571.0

NOTE All categories are established for classification of products. Products may not be available in all categories. Contact your Avago representative for further clarification and information.

Figure 1 Maximum Allowable DC Current vs. Ambient Temperature

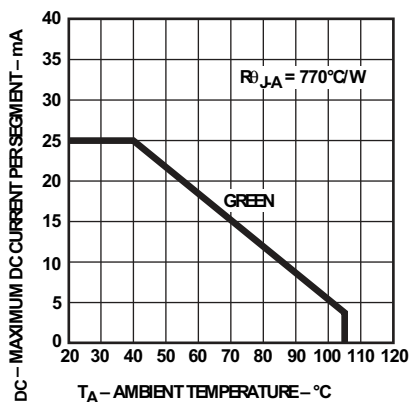

Figure 2 Forward Current vs. Forward Voltage

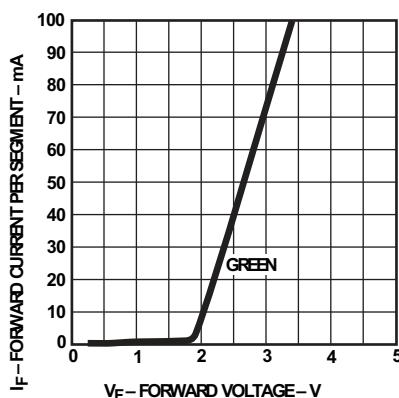
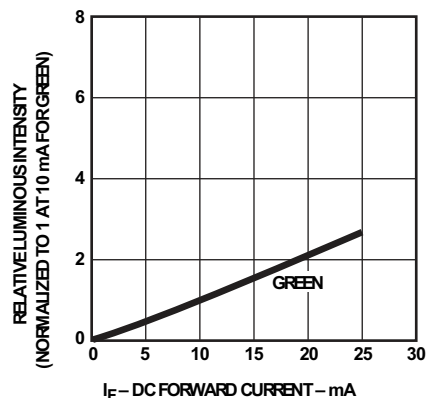

Figure 3 Relative Luminous Intensity vs. DC Forward Current



Contrast Enhancement

For information on contrast enhancement, refer to Application Note 1015.

Soldering/Cleaning

Cleaning agents from the ketone family (acetone, methyl ethyl ketone, etc.) and from the chlorinated hydrocarbon family (methylene chloride, trichloroethylene, carbon tetrachloride, etc.) are not recommended for cleaning LED parts. All of these various solvents attack or dissolve the encapsulating epoxies used to form the package of plastic LED parts.

For information on soldering LEDs, refer to Application Note 1027.

For product information and a complete list of distributors, please go to our web site:

www.avagotech.com

Avago Technologies and the A logo are trademarks of Avago Technologies in the United States and other countries. All other brand and product names may be trademarks of their respective companies.

Data subject to change. Copyright © 2013–2016 Avago Technologies. All Rights Reserved.

AV02-0130EN – March 31, 2016

AVAGO
TECHNOLOGIES

