



#### DESCRIPTION

The LX2208 is a single cell Lithium Ion or Lithium Polymer battery charger. The controller will charge a single cell Li-Ion battery from either a wall adapter or a USB power source. A low under-voltage lockout level increases usable charging range from a current limited power source. In addition, there is a linear die temperature thermal control loop, which limits the heat dissipation while still charging the battery. There are three logic selectable and programmable charge current levels: the high charge programming level is typically set for charging from the wall adapter, the low level charge programming is typically set to 500mA for full USB charging and 100mA (20%) for reduced USB charging.

In addition to setting the high-level charge current, the HCP programming resistor also sets the termination current at 10% of the constant current

level and the conditioning current at 5% of the constant current level. Power status indicators STAT and  $\overline{DCOK}$  can be configured to show charge in progress, battery fully charged and external power on. The STAT pin is capable of sourcing or sinking 5mA. The  $\overline{DCOK}$  output is an open drain output and can sink 10mA.

The LX2208 enters a low quiescent current shut down when power is removed from the IN pin or when it is logically shutdown to minimize battery drain.

Protection features include: under voltage lock out, reverse current blocking on the IN pin, internal die temperature thermal loop to reduce charge current to maintain a safe die temperature, and a unsafe battery temperature charge inhibitor. For charging deeply discharged batteries, the controller includes a conditioning charge mode. The LX2208 comes in a 3x3mm 12 pin MLPD package.

**IMPORTANT:** For the most current data, consult MICROSEMI's website: <http://www.microsemi.com>

#### KEY FEATURES

- Up to 2A Charging Current
- Integrated Power MOSFET
- Three Charge Levels for Adapter, and USB Hi and Low
- Charge Battery from a Current Limited Adapter
- 0.5% Battery Voltage Accuracy
- USB Current Compliance
- Battery Full Indicator
- CC/CV with Thermal Feedback
- Battery Temperature Monitor
- Precision Charge Termination

#### Protection features:

- Unsafe Battery Temp Lockout
- Internal IC Temp Regulator
- USB Current Limiter
- Reverse Current Blocking
- Under Voltage Lockout
- False Termination Prevention under Low Supply Conditions

#### APPLICATIONS

- Navigation Devices
- Multi-Media Players
- Handheld Devices
- Digital Cameras

#### PRODUCT HIGHLIGHT

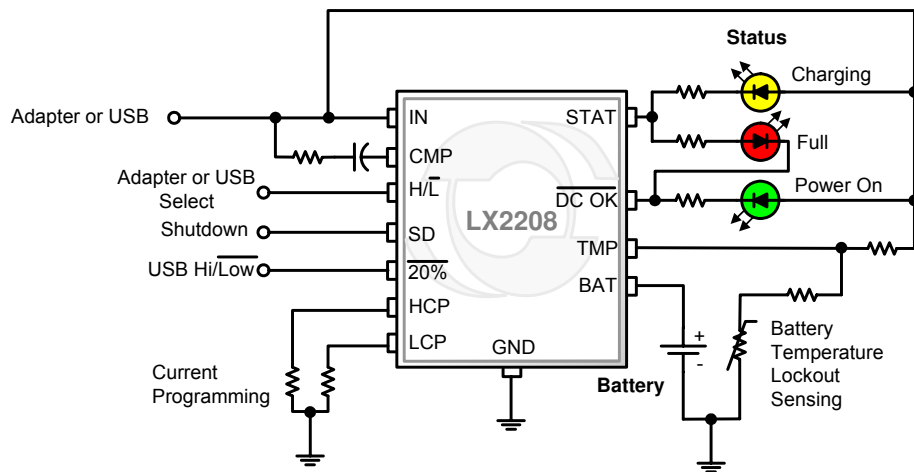

#### PACKAGE ORDER INFO

$T_A$ (°C)	<b>LD</b>	<b>Plastic MLPD 3 x 3mm 12 pin</b>
		RoHS Compliant / Pb-free
-40 to 85		<b>LX2208ILD</b>
Note: Available in Tape & Reel. Append the letters "TR" to the part number. (i.e. LX2208ILD-TR)		



#### ABSOLUTE MAXIMUM RATINGS

Supply Input Voltage (IN, BAT) .....	-0.3V to 7V
All other pins .....	-0.3V to V <sub>SUPPLY</sub>
Battery Charging Current .....	2.5A
Operating Ambient Temperature Range (T <sub>A</sub> ) .....	-40 to 125°C
Maximum Operating Junction Temperature .....	150°C
Storage Temperature Range .....	-65°C to 150°C
Lead Temperature (Soldering 10 seconds).....	300°C
Peak Temp. for Solder Reflow (40 seconds maximum exposure).....	260°C (+0 -5)

Note: Exceeding these ratings could cause damage to the device. All voltages are with respect to Ground. Currents are positive into, negative out of specified terminal.

#### PACKAGE PIN OUT

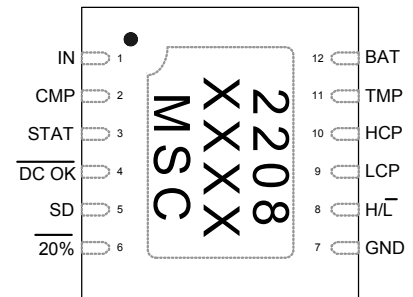

**LD Package**  
(Top View)

RoHS / Pb-free 100% matte Tin Pin Finish

#### THERMAL DATA

#### **LD** Plastic Micro Leadframe Package 12-Pin

<b>THERMAL RESISTANCE-JUNCTION TO AMBIENT, <math>\theta_{JA}</math></b>	<b>33°C/W*</b>
---	----------------

Junction Temperature Calculation:  $T_J = T_A + (P_D \times \theta_{JA})$ .

\*The  $\theta_{JA}$  numbers are guidelines for the thermal performance of the device/pc-board system. All of the above assume no ambient airflow. See layout guidelines section for important details.

#### FUNCTIONAL PIN DESCRIPTION

Name	Pin	Description
BAT	12	Output, Battery Connection – This pin is wired to the positive terminal of a single cell Lithium Ion/Polymer battery.
CMP	2	Input, Compensation – Connect a series combination of a 1k resistor and 0.47 $\mu$ F capacitor from IN to CMP.
$\overline{\text{DC OK}}$	4	Output, Power status logic pin and LED driver – This pin is an open drain output that can sink 10mA of current to drive an external LED. This pin is low impedance to GND when the IN pin input voltage is high enough to charge the battery.
GND	7	Common Ground – Used as chip ground and as a reference for the battery return.
HCP	10	Input, High Current Programming and Termination Current Programming – A resistor (R <sub>HCP</sub> ) between this pin and GND sets the constant current high level. The following relationship determines the charging current of constant current mode: Typically I <sub>BAT</sub> =7150/R <sub>HCP</sub> when H/ $\bar{L}$ is high. The termination current is set to 1/10 of the HCP current level, and the conditioning current is set to 1/20 of the HCP current level.
H/ $\bar{L}$	8	High or Low load select logic input – A logic high selects the constant charge current level set by the HCP pin resistor R <sub>HCP</sub> and a logic low selects the constant charge current level set by the LCP pin resistor R <sub>LCP</sub> .
IN	1	Input Power – Connect to a wall adapter or a USB port.
LCP	9	Input, Low Current Programming – A resistor (R <sub>LCP</sub> ) between this pin and GND sets the constant current low level. The following relationship determines the charging current of constant current mode: Typically I <sub>BAT</sub> =7150/R <sub>LCP</sub> when H/ $\bar{L}$ is low and 20% is high.
SD	5	Input, Shutdown – A logic high places the LX2208 in shut down mode; it can also be used for USB suspend mode.
STAT	3	Output, Charging status logic pin and LED driver – This pin can source or sink 5mA of current to drive an external LED in either output state. This pin is low when the battery is in charging mode and becomes high when the charge cycle is finished. It becomes high impedance when the input power is removed.
TMP	11	Input, Battery Temperature Monitor – This sense pin determines the battery temperature. It is connected to a resistor network as defined in the application note. When the TMP pin falls below 29% (typ) of V <sub>IN</sub> or rises above 74% (typ) of V <sub>IN</sub> it suspends charging. Ground the TMP pin if it is not used.
$\overline{20\%}$	6	$\overline{20\%}$ Select logic input – This pin is only monitored when the H/ $\bar{L}$ pin is low. A logic high on $\overline{20\%}$ pin selects the constant charge current level set by the LCP pin resistor R <sub>LCP</sub> . A logic low selects 20% of the constant charge current level set by the LCP pin resistor R <sub>LCP</sub> .



### ELECTRICAL CHARACTERISTICS

Unless otherwise specified, the following specifications apply over the operating ambient temperature  $-40^{\circ}\text{C} \leq T_A \leq 85^{\circ}\text{C}$  and the following test conditions:  $V_{IN} = 5.0\text{V}$ ;  $V_{SD} = \text{Low}$ ;  $V_{H/L} = \text{High}$ ,  $V_{20\%} = \text{High}$ ;  $V_{BAT} = 3.6\text{V}$ ;  $R_{HCP} = 15.8\text{k}$ ,  $R_{LCP} = 15.8\text{k}$ ;  $V_{TMP} = 0\text{V}$ .

Parameter	Symbol	Test Conditions	LX2208			Units
			Min	Typ	Max	
<b>INPUT CIRCUITRY</b>						
Input Voltage	$V_{IN}$		4.35	5	6	V
Under Voltage Charging Lockout	$V_{IN(UVLO)}$	Rising input $V_{BAT} = 2.8\text{V}$	2.9	3.1	3.3	V
IN UVLO Hysteresis				225		mV
IN Input Supply Current	$I_{IN}$	$V_{BAT} = 4.2\text{V}$ (battery charged)		1	2	mA
		SD = High (shutdown mode)		10	50	$\mu\text{A}$
<b>BATTERY CHARGER</b>						
Constant Voltage Charging	$V_{BAT}$	$I_{BAT} < 100\text{mA}$ @ $25^{\circ}\text{C}$ (4.5V to 5.5V)	4.18	4.2	4.22	V
Constant Voltage Charging	$V_{BAT}$	$I_{BAT} < 100\text{mA}$ (4.5V to 5.5V)	4.16	4.2	4.24	V
Constant Voltage Charging	$V_{BAT}$	$I_{BAT} < 100\text{mA}$ (4.35V to 6V)	4.10	4.2	4.24	V
Charge Current	$I_{BAT}$	$R_{HCP} = 3.57\text{k}$	1800	2000	2200	mA
Charge Current	$I_{BAT}$	$R_{HCP} = 7.15\text{k}$	900	1000	1100	mA
Charge Current	$I_{BAT}$	$R_{HCP} = 15.8\text{k}$	400	453	500	mA
Low Level Charge Current	$I_{BAT}$	$V_{H/L} = \text{Low}$	408	453	476	mA
20% Charge Current Ratio	$I_{BAT}$	$I(V_{20\%} = \text{Low}) / I(V_{20\%} = \text{High}); V_{H/L} = \text{Low}$	18	20	22	%
Condition Current	$I_{BAT}$	$V_{BAT} < V_{CCT}$ ; $R_{HCP} = 3.57\text{k}$	50	100	150	mA
Condition Current	$I_{BAT}$	$V_{BAT} < V_{CCT}$ ; $R_{HCP} = 7.15\text{k}$	25	50	75	mA
Conditioning Current Threshold	$V_{BAT}$	Rising Battery Voltage	2.5	2.7	2.9	V
Termination Current	$I_{BAT}$	$R_{HCP} = 3.57\text{k}$		250		mA
Termination Current	$I_{BAT}$	$R_{HCP} = 7.15\text{k}$		125		mA
Top Off Threshold	$V_{BAT}$	$0^{\circ}\text{C} \leq T_A \leq 85^{\circ}\text{C}$	96	97	98	%
Top Off Threshold	$V_{BAT}$	$-40^{\circ}\text{C} \leq T_A \leq 85^{\circ}\text{C}$	96	97	98.5	%
Battery Drain Current	$I_{BAT}$	$V_{BAT} = 4.2\text{V}$ (battery charged, $V_{IN} > 4.5\text{V}$ )		5	15	$\mu\text{A}$
Battery Drain Current	$I_{BAT}$	$V_{BAT} > V_{IN}$		5	15	$\mu\text{A}$
Battery Drain Current	$I_{BAT}$	$V_{SD} = \text{High}$ (shutdown mode)		2.5	5	$\mu\text{A}$
<b>LOGIC</b>						
STAT High Output	$V_{STAT}$	$V_{IN} = 5.0\text{V}$ , $I_{DRV} = -5\text{mA}$	4.2	4.5	5	V
STAT Low Output	$V_{STAT}$	$V_{IN} = 5.0\text{V}$ , $I_{DRV} = 5\text{mA}$			0.5	V
Input Logic : SD, H/L, 20%	$V_{LOG}$	Input Logic Threshold	450	725	1000	mV
Input Current : SD, H/L, 20%	$I_{LOG}$	Input Current, $V_{LOG} = 2\text{V}$	0	2.5	5	$\mu\text{A}$
		Input Current, $V_{LOG} = 0\text{V}$	-2	0	2	$\mu\text{A}$
Output Logic : $\overline{\text{DCK}}$	$V_{LOG(OUT)}$	Logic Hi Output, 10k Pull up to 3.3V	3.2			V
		Logic Low Output, $I_{LOG} = 10\text{mA}$			0.5	V
<b>BATTERY TEMPERATURE MONITOR</b>						
Cold Threshold	$V_{TFB}$	Rising Voltage	72	75	76.5	% $V_{IN}$
Cold Threshold	$V_{TFB}$	Falling Voltage	70.5	72	74	% $V_{IN}$
Hot Threshold	$V_{TFB}$	Falling Voltage	27	28	30	% $V_{IN}$
Hot Threshold	$V_{TFB}$	Rising Voltage	28	30	31	% $V_{IN}$
TFB Disable Volt	$V_{TFB}$		70	100	150	mV



### SIMPLIFIED BLOCK DIAGRAM

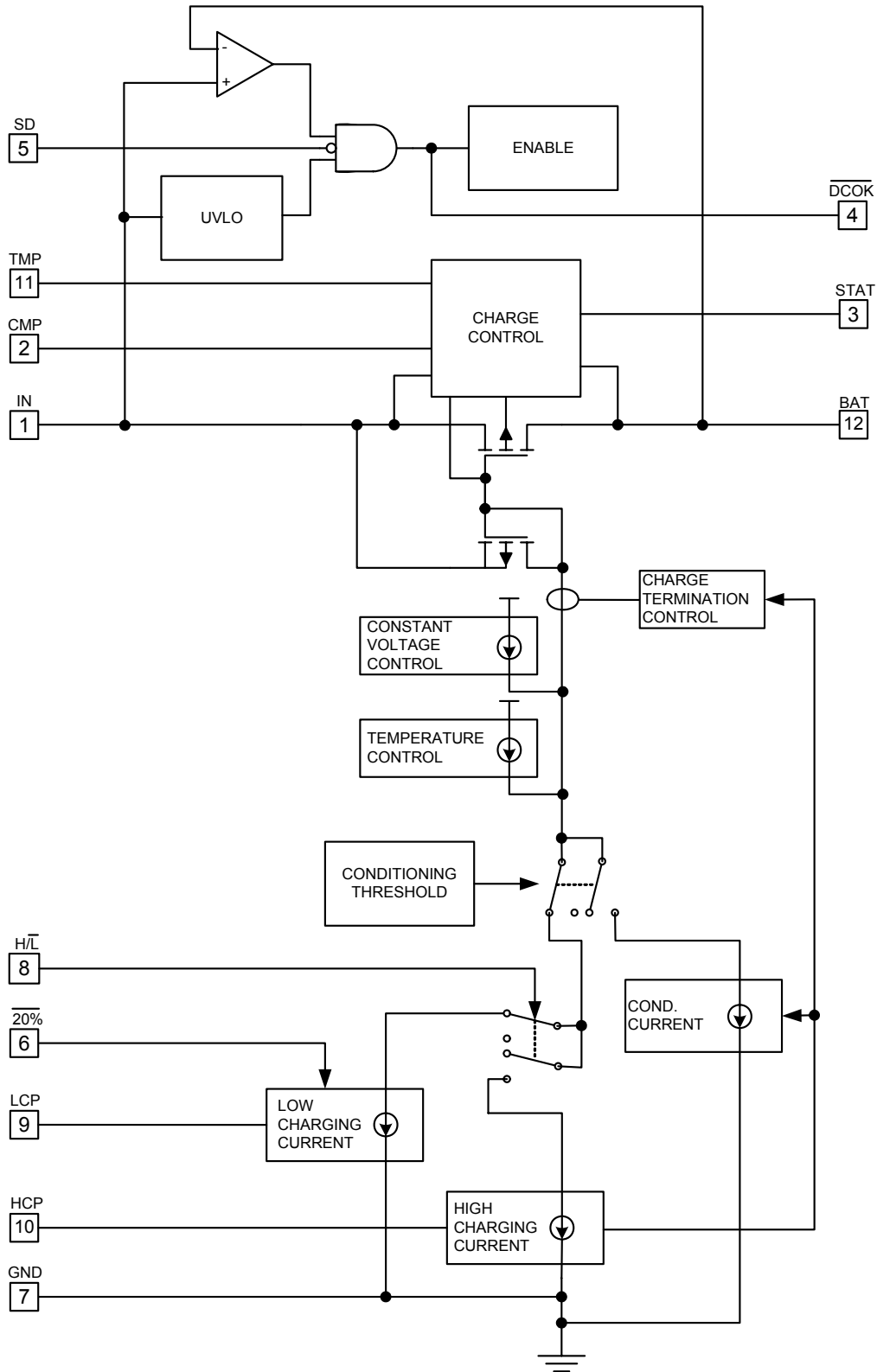



### CONTROL LOGIC DIAGRAM

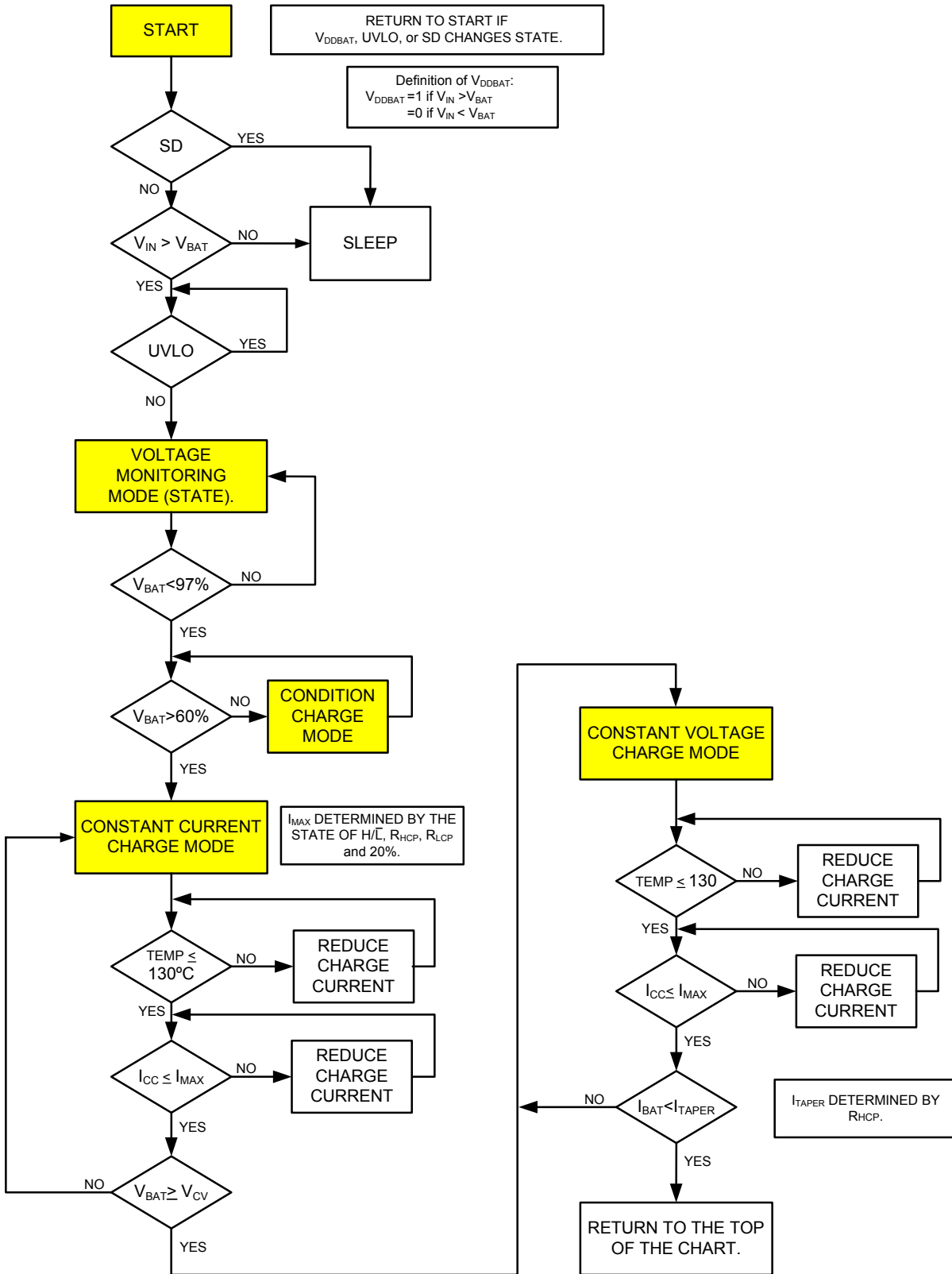



### APPLICATION CIRCUITS

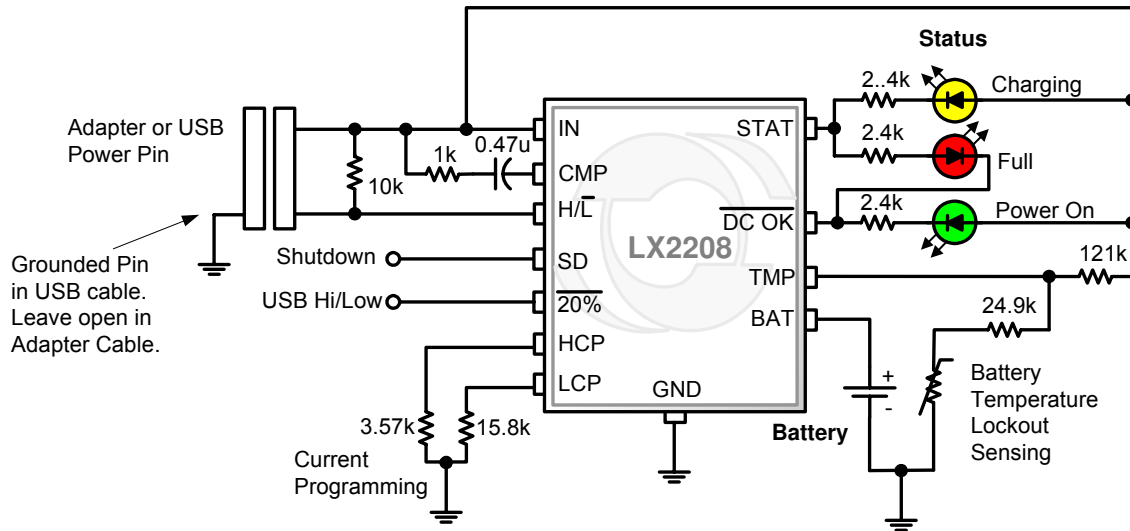

**Figure 1** – Typical Application – 2A adapter charge current and 500mA or 100mA maximum USB charge currents. A grounded spare pin in the USB power cable can be used to sense when the 500mA USB current power source is being used. This application also uses three LED indicators for Power attached, Battery Charging and Battery Full. This configuration also implements circuitry to lockout battery charging if the battery is less than 0°C or greater than 60°C.

**THEORY OF OPERATION****GENERAL DESCRIPTION**

The LX2208 charges a single cell Lithium Ion or Lithium Polymer battery using two steps: a constant current mode followed by a constant voltage mode. The maximum charging current during the Constant Current Mode of the charging profile can be logically set (using  $\overline{H/L}$  pin) to two resistor-programmable levels. The resistor  $R_{HCP}$  connected between HCP and GND pin sets the higher level current. The resistor  $R_{LCP}$  connected between LCP and GND pin sets the lower level current. There is also a  $\overline{20\%}$  logic input that selects either the full current set by the LCP resistor  $R_{LCP}$  or 20% of that value. The charger will terminate constant voltage charging once the current drops below the taper current setting which is 10% of the high charge current setting (determined by HCP resistor  $R_{HCP}$  value).

**CONDITIONING CURRENT CHARGE MODE**

A conditioning current is applied to batteries that are deeply discharged and have a terminal voltage less than 60% of the constant voltage level. The conditioning current is 5% of the HCP programmable constant current level. Once the battery terminal voltage exceeds the conditioning current threshold, the full constant current level is applied (unless charging current is limited by one of the other charger control loops).

**CHARGE TERMINATION MODE**

To increase system battery life and avoid float charging, the LX2208 disconnects the charger once the battery has been fully charged. The charge termination state occurs at the end of constant voltage mode. The termination current is set by the value of the resistor  $R_{HCP}$  connected between HCP pin and GND. The STAT pin changes state when charging is completed.

**TOP OFF CHARGE MODE**

Once the charger has completed a charge cycle, if power remains applied, the LX2208 enters a Voltage Monitoring mode. In this mode, the LX2208 monitors the battery terminal voltage and applies a top off charge if the battery voltage drops below the top off threshold.

**ADAPTER OR USB SELECTION**

The LX2208 supports battery charging from a system that provides adapter power or USB power using the same external connector. Figure 1 shows one example of a system using a special USB adapter cable to determine whether the power source is USB or Wall Adapter. Similarly, if the system processor senses the absence of USB data, it can logically set the  $\overline{H/L}$  logic level high to allow a higher charge current to be used.

**INPUT SUPPLY QUALIFICATION**

If the input supply is not high enough for the internal 4.2V reference to operate, charge termination will be prevented. This may be useful if supply is severely current limited.

**USB CHARGE MODE AND CURRENT LIMIT**

The LX2208 is fully compliant with, and supports, the USB specifications – the Low Power Peripheral (100mA) and High Power Peripherals (500mA). USB current levels can be set using the appropriate values of the LCP programming resistor  $R_{LCP}$ .  $\overline{20\%}$  logic input selects USB high/low charge current. When the SD pin is pulled high, the USB input enters Shut Down mode and will not present a load to the IN pin.

 **$\overline{DC OK}$** 

The IN input is monitored and  $\overline{DC OK}$  is set to a logic low to report the presence of the power source with sufficient voltage to charge the battery. The  $\overline{DC OK}$  threshold is the larger of the UVLO threshold or the battery voltage.

**PROTECTION FEATURES**

**Conditioning Current Mode** – If the battery terminal voltage is less than 2.7V, the battery charger will reduce the charge current to 5%. This also protects the appliance from overheating by trying to drive the full charging current into a short circuited battery.

**Under Voltage Lockout** – The charge cycle will not start until the IN voltage rises above 3.1V. Hysteresis helps alleviate chattering on and off.

**Thermal Control Loop** – If the power dissipation of the charger becomes excessive, the charge current will be linearly reduced to prevent the die temperature from getting above 140°C. This does not cause the charge cycle to stop.

**Reverse Current Blocking** – If IN input is grounded, current will not flow from the BAT pin through the charger. No external blocking diode is required on the input.

**Shut Down Mode** – If the SD pin is asserted a logic high, the charger enters a shut down mode where a very low quiescent current prevents drain from the battery.



### APPLICATION NOTE

#### LAYOUT

In the layout of the Printed Circuit Board (PCB) it is important to provide a low thermal impedance path from the thermal pad on the bottom of the LX2208 package to the ground plane of the circuit board to maximized heat dissipation. Generally this is accomplished by the use of multiple thermal vias. This insures the LX2208 stays cool and can provide the maximum charge current to minimize the time required to charge the battery.

For latch-up prevention purpose, it is important to place 10µF capacitors (X5R or X7R dielectric) close to the IN and BAT pins. With long input cables to the adapter or USB, it is best to use a sheathed cable or twisted wire cable which is typical of most applications.

The CMP 0.47µF capacitor and 1k resistor should be placed close to the CMP pin and IN pin; the CMP pin is located adjacent to the IN pin to facilitate this.

#### CURRENT PROGRAMMING RESISTORS

The LX2208 has two programming resistors to control the battery charging current during the constant current charging mode of the battery charging cycle. When the H/L pin is high (selecting the High Current charging mode), the charge current is determined by the value of the HCP programming resistor  $R_{HCP}$ . The maximum charge current is determined by the programming current at either the HCP or LCP programming pins (depending on the state of H/L); the range of each of these channels is identical. The programming current is the HCP or LCP pin voltage (typically 1.25V) divided by the value of the programming resistor. For example, the HCP current with a 7.15k resistor to GND is:

$$I_{HCP} = \frac{1.25}{R_{HCP}} = \frac{1.25}{7.15k} = 175\mu A$$

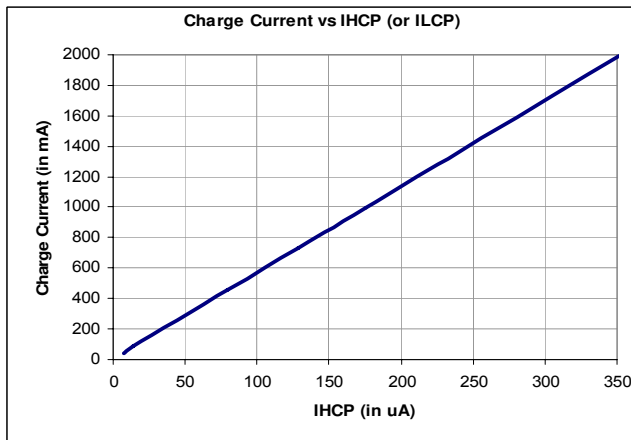

Using the table above it can be seen that for a programming current value of 175µA, the corresponding maximum charge current is 1A.

The termination current determines the point at which the charge cycle is terminated and the battery is determined to be fully charged. The termination current is determined by the value of the HCP programming current as determined by the HCP programming resistor  $R_{HCP}$ . For a value of  $I_{HCP} = 175\mu A$  (as was used in the previous example), the termination current from the chart below can be seen to be 100mA.

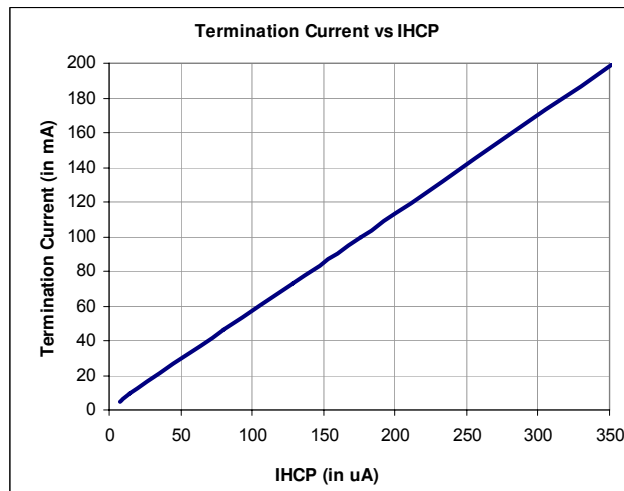

The termination current is always roughly 10% of the maximum charge current set by the HCP resistor  $R_{HCP}$ .

Constant Charge Current (in mA)	$R_{HCP}$
43.3	169.28k
92	88.67k
460	15.80k
730	9.75k
1000	7.15k
2000	3.56k*

\*  $R_{HCP}$  minimum value

Termination Current (in mA)	$R_{HCP}$
4.33	169.28k
9.2	88.67k
46	15.80k
73	9.75k
100	7.15k
200	3.56k*



**APPLICATION NOTE**
**BATTERY TEMPERATURE MONITOR**

The LX2208 has an input to monitor the battery temperature during battery charging; this method assumes the battery pack contains a thermistor expressly for this purpose. A typical Lithium Ion battery should only be charged within a temperature range of 0°C to 60°C. For this calculation, a Vishay NTHS0402N01N1003J Thermistor was used. This thermistor has the value of 327kΩ at 0°C, 100kΩ at 25°C and 24.9kΩ at 60°C. The thermistor must be biased with a Thevenin voltage source and series resistance to achieve the proper TMP thresholds. A fixed value resistor is added in series with the thermistor to prevent it from becoming too low impedance at high temperatures and causing the TMP input to default to off.

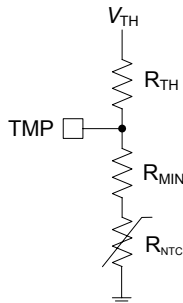

Using a value of  $R_{MIN}$  that is equal to the thermistor temperature at 60°C works well; therefore, for this example, set the value of  $R_{MIN}$  to 24.9k. This has the effect of adding 24.9k to the thermistor resistance values so it becomes 352kΩ at 0°C, 125kΩ at 25°C and 49.8kΩ at 60°C.

The equations for  $R_{TH}$  and  $V_{TH}$  are, using Cold Temperature Fault Threshold average of 74% and the Hot Temperature Fault Threshold average of 29% of  $V_{IN}$ :

$$\frac{V_{TH}}{V_{IN}} = \frac{0.29 \times 0.74 \times (R_{T=0^{\circ}C} - R_{T=60^{\circ}C})}{(0.29 \times R_{T=0^{\circ}C}) - (0.74 \times R_{T=60^{\circ}C})}$$

$$= K = 0.99$$

$$R_{TH} = \left( \frac{K}{0.74} - 1 \right) \times R_{T=0^{\circ}C} = 121k$$

Where R at temperature is the sum of the thermistor plus  $R_{MIN}$ .

To finish the design it is necessary to create the Thevenin Voltage and resistance using a voltage divider from the input pin (IN).

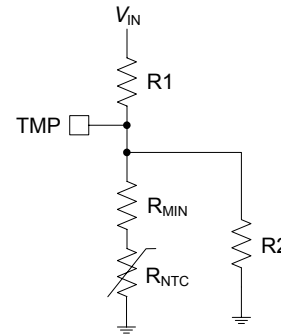

The values of R1 and R2 can be calculated as:

$$R1 = \frac{R_{TH}}{K} = 122k$$

$$R2 = \frac{R1 \times R_{TH}}{R1 - R_{TH}} = 14,800k$$

In this case, it is not necessary to use R2, because the value is so large it is insignificant. In this case,  $R1 = R_{TH}$ .

The final circuit for this example is:

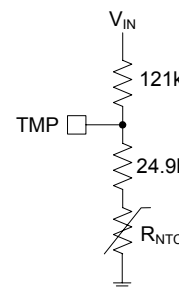

The TMP voltages with this circuit are:

TEMP (°C)	R <sub>NTC</sub>	V <sub>TMP</sub> (%V <sub>IN</sub> )
-20	971k	89%
0	327k	74%
25	100k	51%
60	24.9k	29%
80	12.6k	24%

At the trip point threshold, there may be chattering on and off of the charging current. However, as the temperature increases or decreases further from the trip point threshold, the chattering will stop.



### APPLICATION NOTE

#### POWER STATUS INDICATORS

The STAT pin is designed to source or sink current. LEDs can be configured to indicate charging or battery full. The battery full indicator can be connected to  $\overline{DC\ OK}$  rather than GND to insure it is off when the input power is removed and the STAT pin and  $\overline{DC\ OK}$  pin go to a high impedance state.

Conditions	STAT
Charge in Process	Low
Charge Completed	High
Input Power Removed	Hi Z

### CHARGING PROFILE

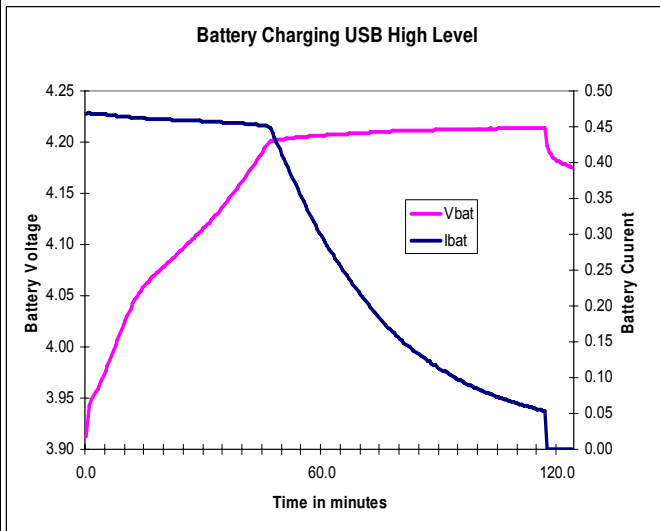

### CONDITIONING CURRENT

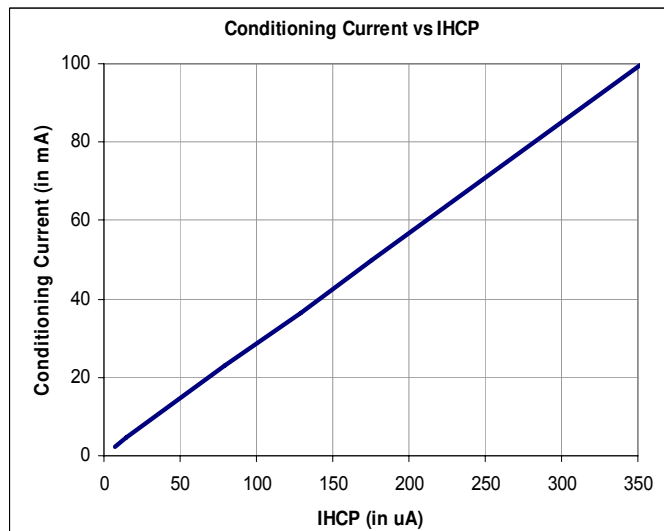



### PACKAGE DIMENSIONS

#### LD

#### 12-Pin Plastic MLP Dual Exposed Pad

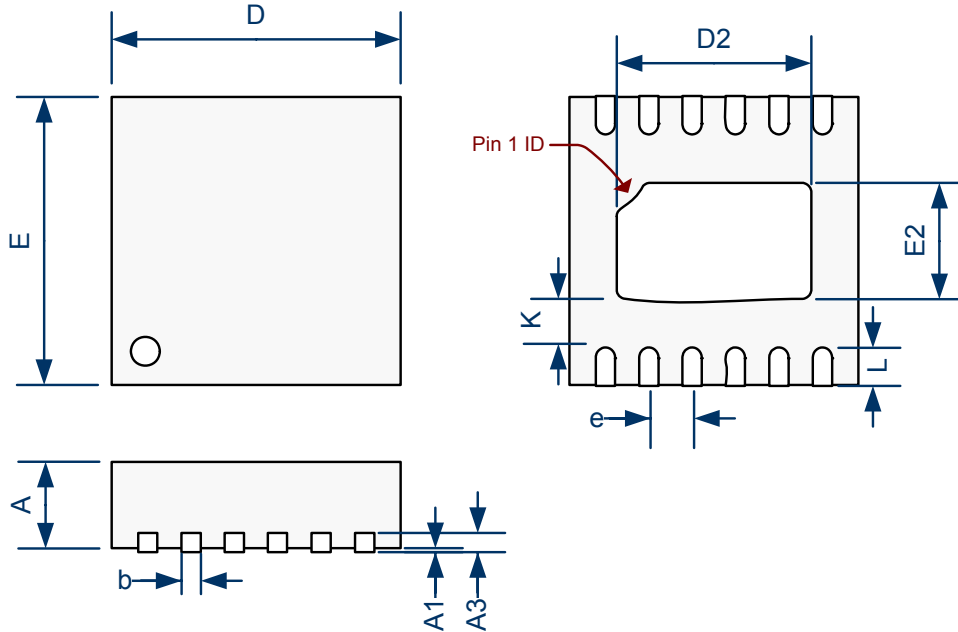

Dim	MILLIMETERS		INCHES	
	MIN	MAX	MIN	MAX
A	0.80	1.00	0.031	0.039
A1	0.00	0.05	0.000	0.002
A3	0.20 REF		0.008 REF	
D	3.00 BSC		0.118 BSC	
E	3.00 BSC		0.118 BSC	
D2	1.87	2.12	0.074	0.083
E2	1.06	1.31	0.042	0.052
e	0.45 BSC		0.018 BSC	
K	0.20 MIN		0.008 MIN	
L	0.30	0.50	0.012	0.020
b	0.15	0.25	0.006	0.010

#### Note:

- Dimensions do not include mold flash or protrusions; these shall not exceed 0.155mm(.006") on any side. Lead dimension shall not include solder coverage.

PRODUCTION DATA – Information contained in this document is proprietary to Microsemi and is current as of publication date. This document may not be modified in any way without the express written consent of Microsemi. Product processing does not necessarily include testing of all parameters. Microsemi reserves the right to change the configuration and performance of the product and to discontinue product at any time.