

## Mechanical Dimensions: Inches [mm]

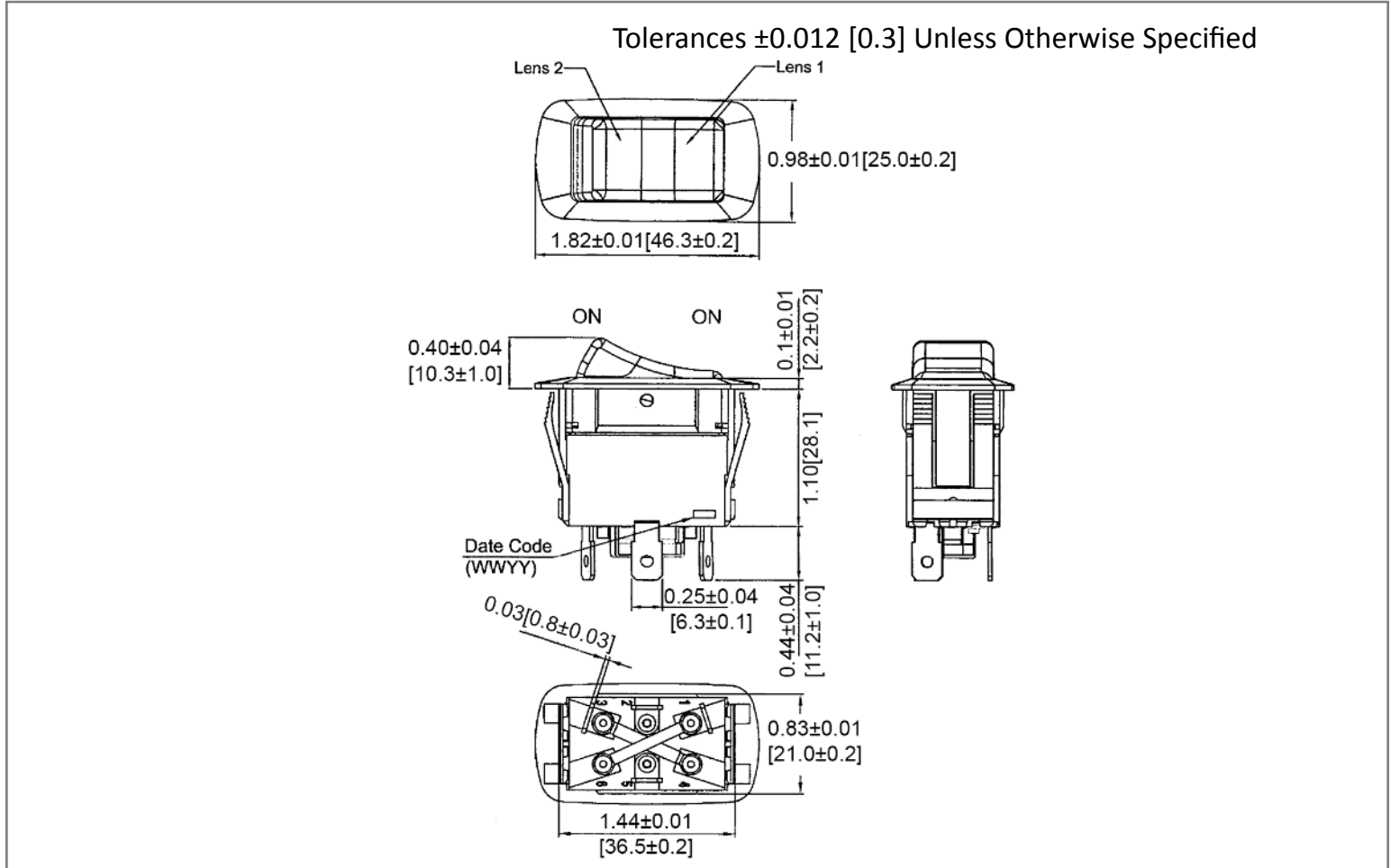

## Mounting Hole

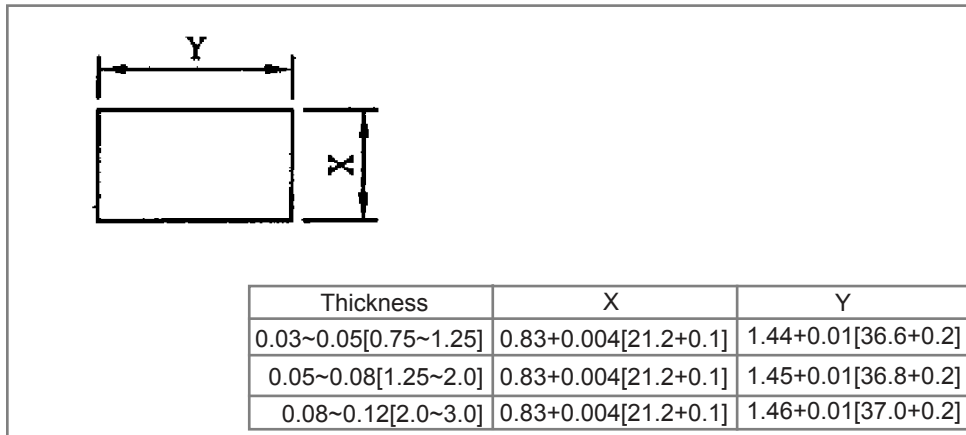

## Circuit Diagram

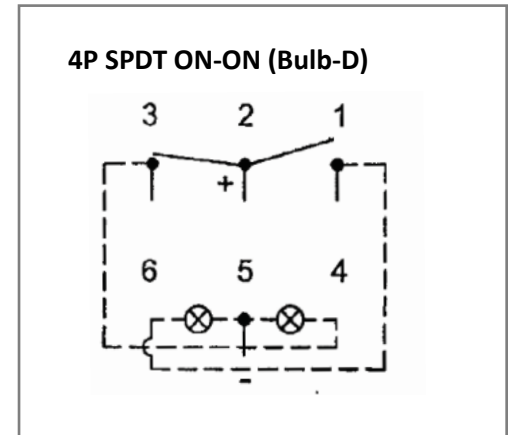

## Electrical Specifications

Rating	21A 14V DC	
Contact Resistance	50m ohm Max	
Insulation Resistance	DC 500V 100M ohm Min	
Dielectric Strength	AC 1500V 1minute	
Operation Temperature	-20°C~85°C	

## Material Specifications

Frame	Black, Nylon #66
Lens 1	PC, Green
Lens 2	PC, Green
Actuator	Black, Nylon 66 +33%GF
	IP-56

**Rev**    **Date of issue**    **Revision Notes**

**Designed**    **Approved**

B	02-26-2020	Initial Drawing	RC	OF
---	------------	-----------------	----	----