

CONTACT ORIENTATION ON ROLL

NOTES: (UNLESS OTHERWISE SPECIFIED)

1. MATERIAL:
 - 1.1 CONTACT BODY: COPPER ALLOY.
 - 1.2 OUTER SPRING: STAINLESS STEEL.
2. SPECIFICATIONS:
 - 2.1 CURRENT RATING: 5A MAX.
 - 2.2 TERMINATION TYPE: CRIMPING.
 - 2.3 WIRE RANGE: 30~28AWG.
 - 2.4 WIRE INSULATION DIA(MAX): Ø1.8mm.
3. RoHS COMPLIANT.
4. ALL DIMENSIONS ARE FOR REFERENCE USE ONLY.
5. AVAILABLE TOOLS:
 - 5.1 HAND CRIMPER: MFX-3958. A3
 - 5.2 CRIMP APPLICATOR: MFX-3957.
 - 5.3 EXTRACTION TOOL: QXRT20.

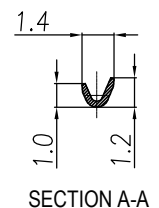
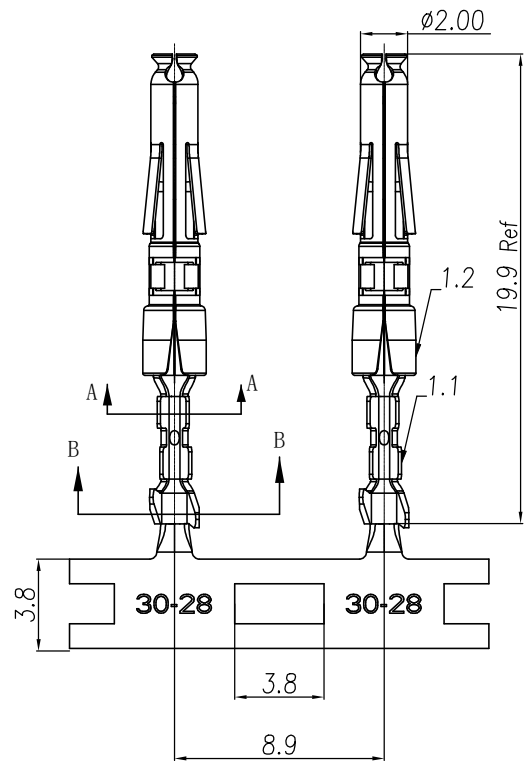

SECTION A-A

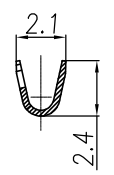

SECTION B-B

REVISIONS					
REV	ECO	DESCRIPTION	DATE	BY	APPR
A1	-	RELEASED DRAWING	Nov-9-17	Rookie	Tommy
A2	-	ADD THE G5 PART NUMBER	Jan-28-19	Blink	Tommy
A3	-	CHANGE HAND CRIMPER	Nov-8-19	Flan	Tommy

P/N	CONTACT PLATING(MATING AREA)
SS28W2T	TIN PLATING OVER NICKEL.
SS28W2N	NICKEL PLATING OVER COPPERIZE.
SS28W2F	GOLD FLASH PLATING OVER NICKEL.
A2 SS28W2G5	5µ" GOLD PLATING OVER NICKEL.
SS28W2G10	10µ" GOLD PLATING OVER NICKEL.
SS28W2G15	15µ" GOLD PLATING OVER NICKEL.
SS28W2G30	30µ" GOLD PLATING OVER NICKEL.

QUANTITY	PART NUMBER	DESCRIPTION	ITEM
MATERIALS LIST			
UNLESS OTHERWISE SPECIFIED 1) All dimensions are in metric(mm). 2) Tolerances are as follows: 1 PL DEC ±0.30 2 PL DEC ±0.15 3 PL DEC ±0.08 3) Note reference =		SIGNATURES DATE DRAWN: <u>Flan</u> <u>Nov-8-19</u> CHECKED: <u>Marin</u> <u>Nov-8-19</u> ENGINEER: APPROVAL: <u>Tommy</u> <u>Nov-8-19</u> CUSTOMER:	<div style="text-align: center;"> <h1>Amphenol</h1> <p>Sine Systems - www.amphenol-sine.com 44724 Morley Drive Clinton Township, MI 48036</p> </div>
MATERIAL SPECIFICATIONS: PROCESS SPECIFICATIONS: NEXT ASSY:		THIS DRAWING IS SUPPLIED FOR INFORMATION ONLY. DESIGN FEATURES, SPECIFICATIONS AND PERFORMANCE DATA SHOWN HEREON ARE THE PROPERTY OF THE AMPHENOL CORPORATION. NO RIGHTS OF REPRODUCTION ARE IMPLIED. ALL DIMENSIONS ARE SUBJECT TO NORMAL MANUFACTURING VARIATIONS.	<div style="text-align: center;"> <p>ECO-MATE, SOCKET CONTACT, STAMPED, 28-30AWG, SIZE 20</p> <p>SIZE TYPE DWG NO. REVISION B C- SS28W2XX A3</p> <p>SCALE NONE SHEET 1 OF 1</p> </div>

TITLE: ECO-MATE, SOCKET CONTACT, STAMPED, 28-30AWG, SIZE 20 DWG NO.: SS28W2XX REV: A3 SH: 1 OF: 1